

PJ500M-C

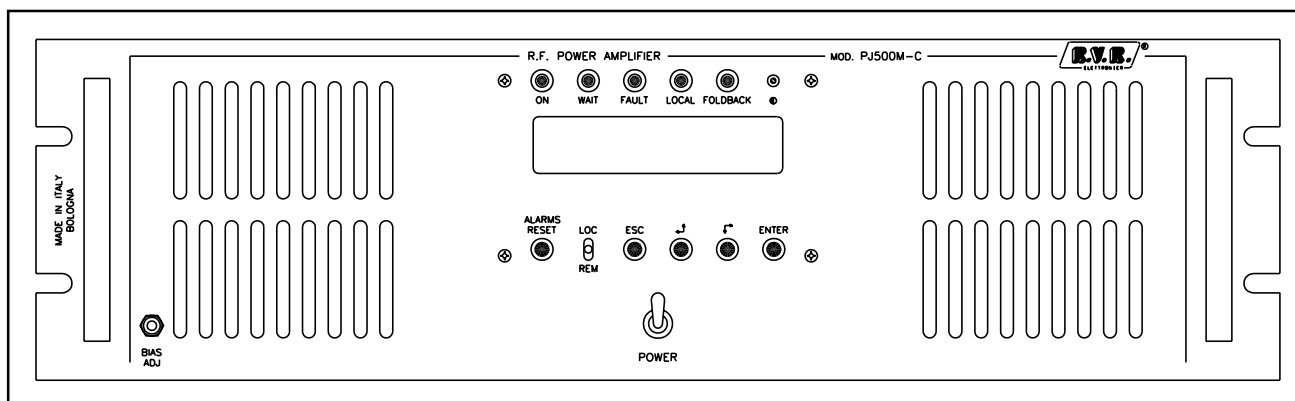

User Manual

LCD Version

Manufactured by  Italy



File name: 500LCD_CHAP_EN.P65

Version: 1.7L

Date: 01/09/2010

Revision History

Version	Date	Reason	Editor
1.4L	25/03/2002	MN700 PS Update	J. Berti
1.5L	14/10/2002	Frontal Bias Adjust Update	J. Berti
1.6L	29/01/2003	A.G.C. Update	J. Berti
1.7L	01/09/2010	Specifications Update	P. Tassin

PJ500M-C - User Manual
Versione 1.7L

© Copyright 1999-2010
R.V.R. Elettronica SpA
Via del Fonditore 2/2c - 40138 - Bologna (Italia)
Telefono: +39 051 6010506
Fax: +39 051 6011104
Email: info@rvr.it
Web: www.rvr.it

All rights reserved

Printed and bound in Italy. No part of this manual may be reproduced, memorized or transmitted in any form or by any means, electronic or mechanic, including photocopying, recording or by any information storage and retrieval system, without written permission of the copyright owner.



Notification of intended purpose and limitations of product use

This product is a FM transmitter intended for FM audio broadcasting. It utilises operating frequencies not harmonised in the intended countries of use.

The user must obtain a license before using the product in intended country of use. Ensure respective country licensing requirements are complied with.

Limitations of use can apply in respect of operating frequency, transmitter power and/or channel spacing.

Declaration of Conformity

Hereby, R.V.R. Elettronica SpA, declares that this FM transmitter is in compliance with the essential requirements and other relevant provisions of Directive 1999/5/EC.



This page intentionally left blank

Table of Content

1. Preliminary instructions	1
2. Warranty	3
3. First Aid	5
3.1 Treatment of electrical shocks	5
3.2 Treatment of electrical Burns	6
4. General Description	7
5. Installation and Use	9
5.1 Preparation	9
5.2 Operation	10
5.3 Software	11
6. Controls, Indicators and Connectors	20
6.1 Front Panel	20
6.2 Rear Panel	21
7. Technical Specifications	22
7.1 Dimensional and Environmental Specifications	22
7.2 Electrical Specifications	22
8. Electrical description	24
8.1 PJ500M-C LCD with MN7000 Option	25
8.2 Power supply	26
8.3 Soft Start	26
8.4 Input directional coupler	26
8.5 RF Power Amplifier	26
8.6 Wilkinson Splitter and Combiner	27
8.7 Bias Card	27
8.8 Low-pass Filter	27
8.9 Output Directional Coupler	27
8.10 CPU	27
8.11 Telemetry connector	28
8.12 External telemetry card (optional)	28
8.13 PFC Switching Power Supply (optional)	29
Appendix:	
Component layouts, schematics, bills of material	

This page was intentionally left blank

1. Preliminary instructions

This manual is written as a general guide for those having previous knowledge and experience with this kind of equipment.

It is not intended to contain a complete statement of all safety rules which should be observed by personnel in using this or other electronic equipment.

The installation, use and maintenance of this piece of equipment involve risks both for the personnel performing them and for the device itself, that shall be used only by trained personnel.

R.V.R. doesn't assume responsibility for injury or damage resulting from improper procedures or practices by untrained/unqualified personnel in the handling of this unit.

Please observe all local codes and fire protection standards in the operations of this unit.



WARNING: always disconnect power before opening covers or removing any part of this unit.

Use appropriate grounding procedures to short out capacitors and high voltage points before servicing.



WARNING: This is a "CLASS A" equipment. In a residential place this equipment can cause hash. In this case can be requested to user to take the necessary measures.

R.V.R. Elettronica SpA reserves the right to modify the design and/or the technical specifications of the product and this manual without notice.

This page was intentionally left blank

2. Warranty

Any product of **R.V.R. Elettronica** is covered by a 24 (twentyfour) month warranty.

For components like tubes for power amplifiers, the original manufacturer's warranty applies.

R.V.R. extends to the original end-user purchaser all original manufacturers warranties which are transferable and all claims are to be made directly to R.V.R. per indicated procedures.

R.V.R.'s warranty shall not include:

- 1) Re-shipment of the unit to R.V.R. for repair purposes
- 2) Any unauthorized repair/modification
- 3) Incidental/consequential damages as a result of any defect
- 4) Nominal non-incidentals defects
- 5) Re-shipment costs or insurance of the unit or replacement units/parts

Warranty shall come into force from invoice date and for the period of the manufacturer's warranty.

Any damage to the goods must be reported to the carrier in writing on the shipment receipt.

Any discrepancy or damage discovered subsequent to delivery, shall be reported to R.V.R. within five (5) days from its receipt.

To claim your rights under this warranty:

- a. Contact the dealer or distributor where you purchased the unit. Describe the problem and ask if he has an easy solution. Dealers and Distributors are supplied with all the information about problems that may occur and usually they can repair the unit quicker than what the manufacturer could do. Very often installing errors are discovered by dealers.
- b. If your dealer cannot help you, contact R.V.R. in Bologna and explain the problem. If it is decided to return the unit to the factory, R.V.R. will mail you a regular authorization with all the necessary instructions to send back the goods.
- c. When you receive the authorization, you can return the unit. Pack it carefully for the shipment, preferably using the original packing and seal the package perfectly. The customer always assumes the risks of loss (i.e., R.V.R. is never responsible for damage or loss), until the package reaches R.V.R. premises. For this reason, we suggest you to insure the goods for the whole value. Shipment must be effected C.I.F. (PREPAID) to the address specified by R.V.R.'s service manager on the authorization.



DO NOT RETURN UNITS WITHOUT OUR AUTHORIZATION AS THEY WILL BE REFUSED.

- a Be sure to enclose a written technical report where mention all the problems found and a copy of your original invoice establishing the starting date of the warranty.

Replacement and warranty parts may be order from the following address. Be sure to include the equipment model and serial number as well as part description and part number.



R.V.R. Elettronica SpA
Via del Fonditore, 2/2c
40138 BOLOGNA
ITALY
Tel. +39 051 6010506

3. First Aid

The personnel employed in the installation, use and maintenance of the device, shall be familiar with theory and practice of first aid.

3.1 Treatment of electrical shocks

3.1.1 If victim is not responsive

follow the A-B-C's of basic life support

- Place victim flat on his back on a hard surface.
- Open airway: lift up neck, push forehead back
- clear out mouth if necessary and observe for breathing
- if not breathing, begin artificial breathing (Figure 2): tilt head, pinch nostrils, make airtight seal, four quick full breaths. Remember mouth to mouth resuscitation must be commenced as soon as possible

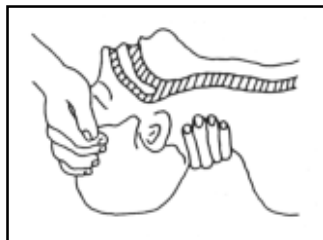

Figure 1



Figure 2

- Check carotid pulse (**Figure 3**); if pulse is absent, begin artificial circulation (**Figure 4**) depressing sternum 1 1/2" TO 2" (**Figure 5**).



Figura 3



Figura 4



Figura 5

- APPROX. 80 SEC. : ONE RESCUER, 15 COMPRESSIONS
- APPROX. 60 SEC.: TWO RESCUERS, 5 COMPRESSIONS, 1 BREATH
- DO NOT INTERRUPT RHYTHM OF COMPRESSIONS WHEN SECOND PERSON IS GIVING BREATH
- Call for medical assistance as soon as possible.

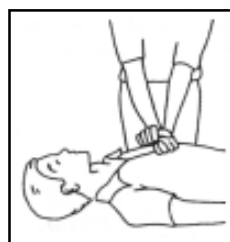
3.1.2 If victim is responsive

- Keep them warm
- Keep them as quiet as possible
- Loosen their clothing (a reclining position is recommended)
- Call for medical help as soon as possible

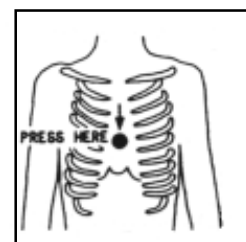
3.2 Treatment of electrical Burns

3.2.1 Extensive burned and broken skin

- Cover area with clean sheet or cloth (Cleansed available cloth article).
- Do not break blisters, remove tissue, remove adhered particles of clothing, or apply any salve or ointment.
- Treat victim for shock as required.
- Arrange transportation to a hospital as quickly as possible.
- If arms or legs are affected keep them elevated

If medical help will not be available within an hour and the victim is conscious and not vomiting, give him a weak solution of salt and soda: 1 level teaspoonful of salt and 1/2 level teaspoonful of baking soda to each quart of water (neither hot or cold). Allow victim to sip slowly about 4 ounces (half a glass) over a period of 15 minutes. Discontinue fluid if vomiting occurs



Do not give alcohol

3.2.2 Less severe burns (1st and 2nd degree)

- Apply cool (not ice cold) compresses using the cleansed available cloth article.
- Do not break blisters, remove tissue, remove adhered particles of clothing, or apply salve or ointment.
- Apply clean dry dressing if necessary.
- Treat victim for shock as required.
- Arrange transportation to a hospital as quickly as possible
- If arms or legs are affected keep them elevated.

4. General Description

RVR Elettronica's PJ500M-C/LCD is a 19" rack-mountable broadband MOSFET RF power amplifier. It works without adjustments on the whole 87.5 - 108 MHz FM band, and its power output is 500 W with a drive level of about 8 W.

The RF power section makes use of two modules, able to deliver more than 300 W each.

The power supply is a switching mode one, and a soft-start circuit is included to minimize the transformer's current spikes when the device is switched on.

The PJ500M-C/LCD is controlled by a microprocessor system including a LCD display, implementing the following functions:

- measurement and display of the amplifier's working parameters
- activation and deactivation of the RF power output
- protection of the amplifier against dangerous situations like exceeding output power or swr, overdrive or overtemperature
- detection of user-settable attention thresholds (e.g. output power being below a certain value), that are made externally available using the "telemetry" connector
- communication with external devices

The amplifier gives the option for an external 24 V dc power supply: this will automatically be used to supply the CPU section in case the mains power goes off, allowing to interact with the device even in such case.

The user can navigate through the menu system using four buttons, ESC, move LEFT/UP, move RIGHT/DOWN and ENTER. Another button is used to reset the alarms that possibly arose.

Five LEDs on the front panel of the amplifier show the current status of the machine: ON/OFF, WAIT, FAULT, LOCAL and FOLDBACK

A switch allows to select the LOCAL or REMOTE mode. LOCAL mode allows to control the machine using the buttons on the front panel, while remote control (that is using the telemetry connector) is disable. In REMOTE mode, buttonson the panel can be used only to read parameters, but they can be changed only remotly.

The PJ500M-C includes the *Automatic Gain Control* feature, that will can be used to fix the RF output power of the amplifier to the desired value so that environmental factors (e.g. temperature) or settings (frequency change) don't impact onto the delivered RF power. The AGC function can be seen as an add-on, meaning that it can be exploited or not depending on the user preferences. More informations about this are given in the manual.

Different working parameters are made available for the user on the telemetry connector, as voltage levels that are proportional to the value of the parameter under consideration.

A built-in low-pass filter keeps the harmonic emission level below the CCIR and FCC permitted levels.

5. Installation and Use

This chapter is intended to summarize the necessary point for the installation of the device. In case any of the arguments is unclear, for example when you use it for the first time, please read carefully the whole manual.

5.1 Preparation

Unpack the amplifier and before any other operation check the unit for any shipping damage and check that all the controls and connectors on the front and rear panels are in good conditions.

Check the mains voltage selector on the rear panel: the position of the jumpers to chose between 220 and 110 mains voltage is indicated on the panel.

Check also the presence and the integrity of the fuses. The required value for the fuses are:

- RF MODULE 25 A 10X38
- A.C. LINE 10 A 6,3X32
- AUX OUT A.C. LINE 4 A 6,3X32

Verify that the mains switch is in the OFF position.

Connect to the RF input the RF output of a suitable exciter (e.g. RVR Elettronica PTX30) using a N-connectors terminated cable; the exciter shall be set for minimum power and OFF.

Turn the "Power Adj." multiturn trimmer on the front panel completely clockwise. This operation disables the intervention of the AGC

Link one of the ALARMS/INTERLOCK connectors to the INTERLOCK connector of the exciter, if available (it is, in RVR Elettronica exciters).

Connect The RF output to the antenna cable or to a suitable dummy load.



Finally, connect a proper cable to the amplifier's mains input.

ATTENTION: the cable has to be disconnected from the mains outlet.

After the cable has been safely connected to the amplifier's mains plug, it is possible to plug it into the mains outlet.

The amplifier shall be mounted in one rack that contain a anti-strap device to not expose accidentally the mains conductors.



ATTENTION: It is essential that the unit is properly earthed to ensure both the safety of operation as well as the correct working of the equipment.

5.2 Operation

Switch the amplifier on and verify the green "ON" LED being lit. The LCD display will indicate a first screen of presentation of the amplifier and next it will switch to a screen indicating the forward and reflected power.

Switch the exciter on (to minimum power level) and wait for it to lock on the working frequency. When the locked condition will be reached, progressively increase its output power, while controlling the amplifier's display. Keep increasing the exciter output until the amplifier reaches the desired level, at most 500W. (Please note that, as result of the digitalization of measurements, it could happen that the displayed value is not exactly 500W, but a value comprised between 495 and 505; this is perfectly normal.)



At this point, the transmitter is set for its nominal power, **but the built-in AGC function is not controlling the output power of the amplifier**. Changes in the exciter's power, or in the environmental conditions could reduce the RF power generated by the amplifier.

To activate the AGC, increase the exciter's output level up to 8 W (the FWD power of the amplifier will reach 540W or more, but its internal limiter will make shure that no harm will be caused to the machine). The exciter's power can also be measured as the amplifier's input power in the "Power Menu", as described later in the manual. Now turn counterclockwise the PWR Adj. trimmer on the front panel of the PJ500M-C observing the reduction in the delivered power of the amplifier, until the desired level is reached.

If the amplifier has to be used at a lower power level, two ways can be followed:

- If the power reduction will be temporary (e.g. for tests), simply reduce the exciter's power until the required level is reached
- If the power reduction will be permanent (that is to have lower transmitted power by the station), first disable the AGC function turning clockwise the PWR Adj. trimmer of the amplifier. Than reduce the exciter's power proportionally to the wanted reduction in the output power of the transmitter. Finally turn the PWR Adj. trimmer counterclockwise until the desired output power is reached

At this point, it is possible for the user to verify all the working parameters of the amplifier using the management software.

Normally, the device doesn't require any human supervision for its normal operation. If any alarm condition arise, these are automatically managed by the embedded protection system, and notified to the user with the LEDs on the panel or via messages on the LCD display.

5.3 Software

This chapter describes in which mode microprocessor system controls the amplifier, and how the user can interact with it.

Note that the user can give commands to the device only when it's set in LOCAL mode using the switch [13] of Figure 1. Otherwise, the user will only be allowed to read the parameters, but not to change any of them.

The flow diagram in figure 3 gives an overall view of the use interface of the software.

At power on, the LCD display will show the following presentation screen, indicating the name of the device and the indication of the switch-on power limiter device named Soft Start:



```
PJ 500 M-C LCD
Soft Start
```

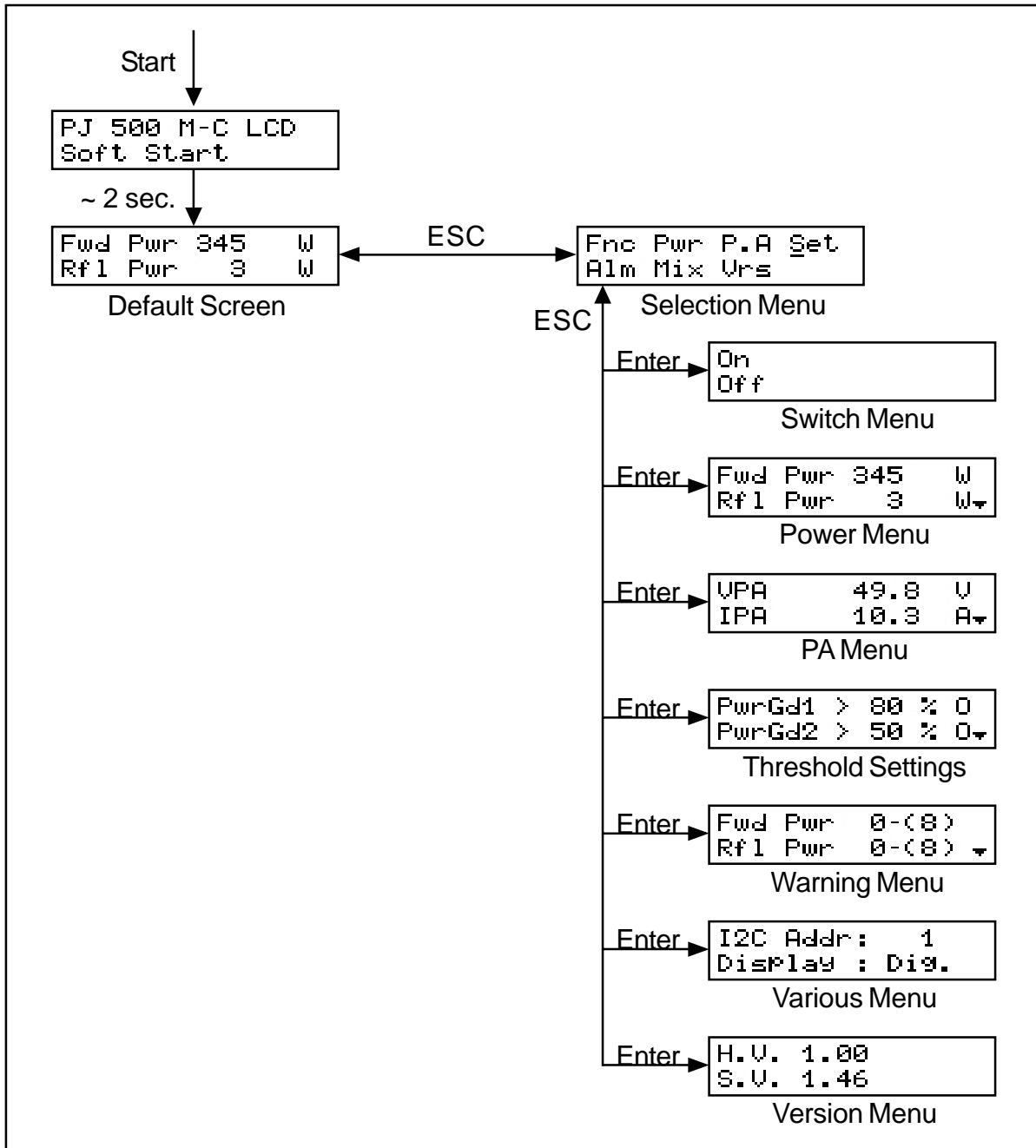

Figure 3 - Software flow diagram

After a few seconds, the main screen will be displayed, reporting the values of Forward power and Reflected power

```

Fwd Pwr 345 W
Rf1 Pwr 3 W
    
```

Pushing the ESC button, the user will be presented with the menu selection screen, from which the other screens can be accessed:

```
Fnc Pwr P.A Set
Alm Mix Urs
```

To enter into another menu, just select the corresponding name (that will be indicated by a flashing underscore) with the LEFT and RIGHT buttons, and then push ENTER.

Note that some of the parameters that are measured and can be read may be, in some circumstances, not available. This situation mostly arises when, for physical reasons, the measured values are not significant to be used in the control software.

When the value for a parameter is not available for such reasons, it's substituted with the symbol ==.

5.3.1 RF Power switch menu (Fnc)

```
On
Off
```

From this screen the user can switch on and off the power amplifier.

When the amplifier is set in the OFF state, the inner conductor of the INTERLOCK connector will be grounded to force the exciter in stand-by mode (if it is fitted with such an option, as RVR exciters are, and if the devices are correctly linked). At the same time, the auxiliary AC power output circuit is opened to shut off the exciter if it is connected to this plug.

A few seconds after the amplifier is set in OFF mode, the software sends a signal to the relays of the blowers to turn them off too (the delay allows for the proper cooling of the amplifier).

5.3.2 Power menu (Pwr)

In this multi-line scrollable screen it is possible to read all the measurements related to the behaviour of the power section of the amplifier:

- Forward Power (Fwd Pwr)
- Reflected Power (Rfl Pwr)
- Standing Wave Ratio (SWR)
- Input Power (Inp Pwr)
- Internal SWR (Int SWR)

Depending on the configuration, some of the measurements can be disabled.

The complete aspect of the screen is the following (please note that only two lines at

a time are visible, use the UP and DOWN buttons to scroll):

Fwd Pwr	345	W
Rf 1 Pwr	3	W
SWR	Off	
InP Pwr	5.2	W
Int SWR	===	W

5.3.3 Power Amplifier menu (P.A.)

In this multi-line scrollable screen it is possible to read the values of the parameters related to the RF amplifier section of the device:

- voltage (VPA)
- current (IPA)
- efficiency
- temperature
- mains voltage (Percentage variation referred to nominal voltage)

The complete aspect of the screen is the following (only two lines at a time are visible, use the UP and DOWN buttons to scroll):

VPA	49.8	V
IPA	10.3	A
Eff.	72.3	%
Temp.	27.3	°C
Mains	+1	%

5.3.4 Threshold setting menu

As it has been said in the introduction, the amplifier offers a maximum of three user settable alarms. For each of them, one of the working parameters is compared against a threshold value that can be modified by the user. The results of the comparisons are available on the telemetry connector or as dry contacts on the optional external telemetry board, and can be read on the display as "O" (open, i.e. the result is false) or "C" (closed, i.e. the result is true).

Two settable thresholds (Power Good) regard the emitted power level, the third is used to verify the quantity of reflected power (Reflected Warning).

The thresholds are shown as percentage of full-scale value.

The full-scale value for PJ500M-C are:

- Forward Power 500W
- Reflect Power 50W

It is also possible to change those values executing the following procedure:

- Select the line to modify (UP and DOWN buttons)
- Push the ENTER button
- Modify the value of the threshold (UP and DOWN buttons)
- Push the ENTER button to confirm

The following figure shows an example of configuration for this menu

PwrGd1	>	80	%	0
PwrGd2	>	50	%	0
Rf1War	>	40	%	0

In this example, the thresholds of the warnings are:

- PwrGd1 400W (80% X 500W)
- PwrGd2 250W (50% X 500W)
- Rf1War 20W (40% X 50W)

5.3.5 Alarms menu

This screen gives to the user information regarding the status of the protection system included in the amplifier.

It consists in a number of lines, each of wich holds the name of the quantity that is checked by the protection system and the kind of intervention that is undertaken.

The latter can be: of the kind X - (Y), Wait, or Disabled.

The aspect of this multi-line screen is the following (only two lines at a time are visible, use the UP and DOWN buttons to scroll):

Fwd Pwr	0-(8)
Rfl Pwr	0-(8)
InP Pwr	0-(8)
U.P.A.	Dis.
I.P.A.	0-(8)
Temp.	Wait
Int SWR	0-(2)
Mains	Wait
SWR	Dis.
Eff.	Dis.

This menu is an help for technic reparator to define eventually problem of power amplificator.

5.3.6 Various menu

This menu permits to effect two operation:

- Setup the address of the I2C serial bus type connection.
- Setup the kind of visualitation in the default menu.

I2C Addr:	1
Display :	Dig.

The default address of I2C communication is fundamental when the amplifier is connected whith other RVR' devices that use this protocol. It's raccomended not to change this parameter if not necessary.

The visualitation mode can be digital (the default mode described in chapter 5.3) or analogic:

Rfl Pwr	6	▼
■ ■		

In analogic mode, a little triangole indicates the reflected power level setting in threshold setting menu (RflWar) and the bar below shows the reflected power in real time.

This kind of visualisation is best used when the amplifier output is connected to a device that needs tuning.

5.3.7 Version menu

This screen shows the different version of hardware (H.V.) and software (S.V.) of the unit.

H.V.	1.00
S.V.	1.46

5.3.8 Protection system

The protection system implemented by the software is based on two kinds of reaction.

The first reaction is called "Foldback", and consists in lowering the RF power stage voltage in case the forward or reflected power surpass a certain value. In this way, the gain of the amplifier gets smaller, and the overall effect is an opposition to the increase of both the forward and the reflected power. A yellow LED on the front panel signals the intervention of the foldback circuit.

The second kind of reaction consists in shutting off the power stages of the amplifier when a certain quantity exceeds the configured value.

Depending on the kind of problem that caused the failure, after the amplifier has been shut off, it will either be reactivated after a fixed time interval, or only when the impeding condition has been solved. In the Alarm menu, the first kind of configuration is noted by **X - (Y)**, while the second is indicated with **Wait**. The third possibility is that the configuration of the system does not implement any protection based on a certain parameter: This would be noted with **Dis.** (Disabled).

While the amplifier is temporarily shut off for an alarm, the yellow WAIT LED is lit, and the cause of the intervention of the protection system is written on the display.

When the protection intervenes for a parameter of "cyclic" kind, a counter is incremented (the value **X** in the alarm screen). If the value of the counter reaches the maximum admitted value (**Y**), the amplifier is definitively switched off, and the red LED "fault" on the front panel is lit.

The button ALARMS RESET gives the user the opportunity to interact with the protection system. Its effect is different depending on the status the amplifier is when the button is pushed:

- If the system is off, waiting for the cycle time to be reached, or if it is definitively off in FAULT state, pushing the ALARMS RESET button will immediately turn the

amplifier on and reset the alarm counters

- If the system is transmitting, but some alarm occurred before, so that the alarm counters are not all at "0", pushing the ALARMS RESET button will have no effect unless the button is pushed while the user is reading the Alarm menu. In this way it is assured that the user doesn't reset the possible alarms without being conscious of them

The alarm counters are reset by the system itself without the need for an external intervention after half an hour of undisturbed (i.e. without alarms) working of the amplifier

6. Controls, Indicators and Connectors

This chapter describes the front and rear panels of the PJ500M-C/LCD, with a brief indication of all the different components.

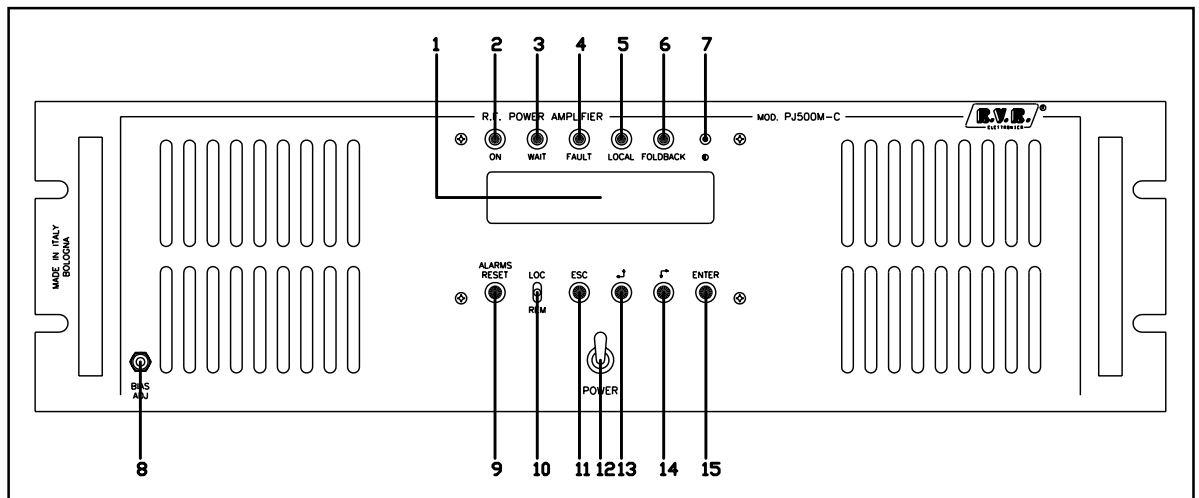

6.1 Front Panel

[1] DISPLAY	LCD Display
[2] ON	Green LED, lit when the amplifier is switched on
[3] WAIT	Yellow LED indicating that the amplifier is waiting for a condition that is blocking the power output to be removed
[4] FAULT	Red LED indicating that a fault that cannot be automatically reverted
[5] LOCAL	Yellow LED indicating that the amplifier in local control mode
[6] FOLDBACK	Yellow LED indicating the intervention of the foldback function (automatic reduction of the output power)
[7] Brightness	Trimmer to regulate the brightness of the LCD display
[8] POWER RESET	Power adjust trimmer - A.G.C. Control
[9] ALARM RESET	Button used to manually reset the protection system
[10] LOC/REM	Switch to select the local or remote control modes
[11] ESC	Button to exit from a menu
[12] ON/OFF	Mains switch
[13] LEFT/UP	Button used to navigate in the menu system and to modify the changeable parameters
[14] RIGHT/DOWN	Button used to navigate in the menu system and to modify the changeable parameters
[15] ENTER	Button used to accept a parameter's value or to enter into a menu

6.2 Rear Panel

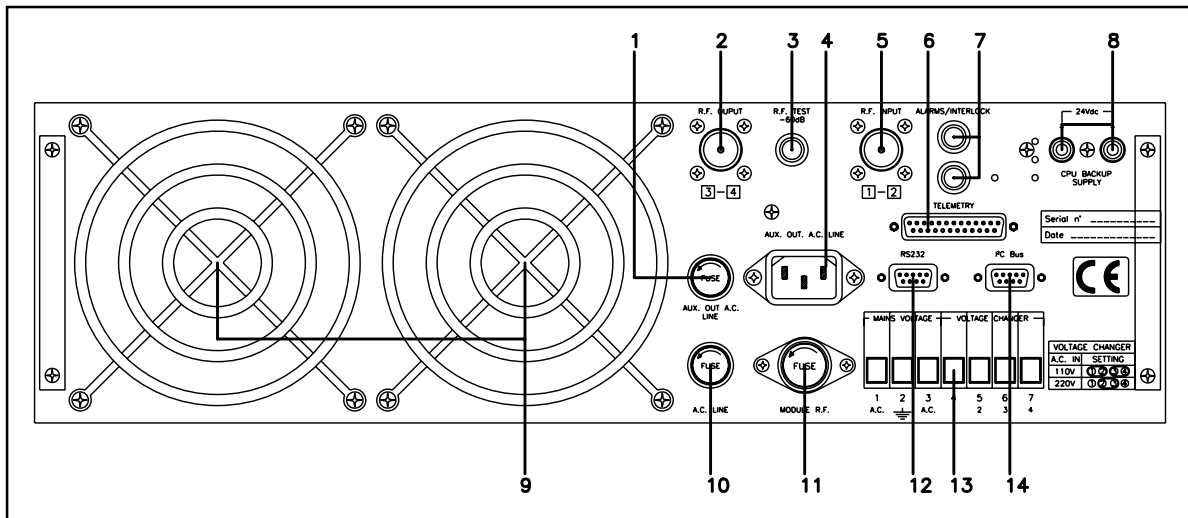

- [1] AUX FUSE Fuse protecting the auxiliary power output
- [2] RF OUT N-type RF output connector
- [3] RF TEST BNC RF monitor output. The output level is -60 dB below the power output in the band 87.5-108 MHz
- [4] AC OUTPUT VDE plug to supply external devices (normally an exciter)
- [5] RF INPUT N-type RF input connector
- [6] TELEMETRY DB25 telemetry connector
- [7] INTERLOCK/ALARMS
BNC connectors to inhibit an external device, as an exciter. In case of fault, the inner connector is shorted to ground
- [8] 24 V External 24 V dc power supply input for CPU backup power supply
- [9] BLOWERS
- [10] MAINS FUSE Mains supply fuse
- [11] RF FUSE Fuse protecting the RF modules
- [12] RS232 DB9 connector to link the amplifier with external devices
- [13] MAINS PLUG Plug for mains supply and voltage setting
- [14] IIC DB9 connector for IIC bus networking

7. Technical Specifications

7.1 Dimensional and Environmental Specifications

Cabinet Dimensions	454.0 mm x 132.5 mm x 507.0 mm
Panel Dimensions	483 mm x 133 mm
Weight	30 Kg
Operating Temperature Range	-10 °C ÷ 50 °C
Umidity	95% Maximum, without condensation

7.2 Electrical Specifications

A.C. Power Supply	115V _{AC} ±10% 230V _{AC} ±10%
Cooling sistem	forced ventilation
Frequency Range	87.5 MHz ÷ 108 MHz
Output Power	500 W nominal
Drive Power	< 8 W for Pout = 500 W, typical 6 W
Input Connector	Standard Connector Type "N"
Input Impedance	50 Ohm
Output connector	Standard Connector Type "N"
Output Impedance	50 Ohm
Harmonic and Spurious Soppression	Respect all requirments FCC e CCIR

This page was intentionally left blank

8. Electrical description

PJ500M-C/LCD is composed of different modules wired between them with connectors, allowing for easy servicing or module substitution.

Figure below shows the upper view of the device with the indication of the different components.

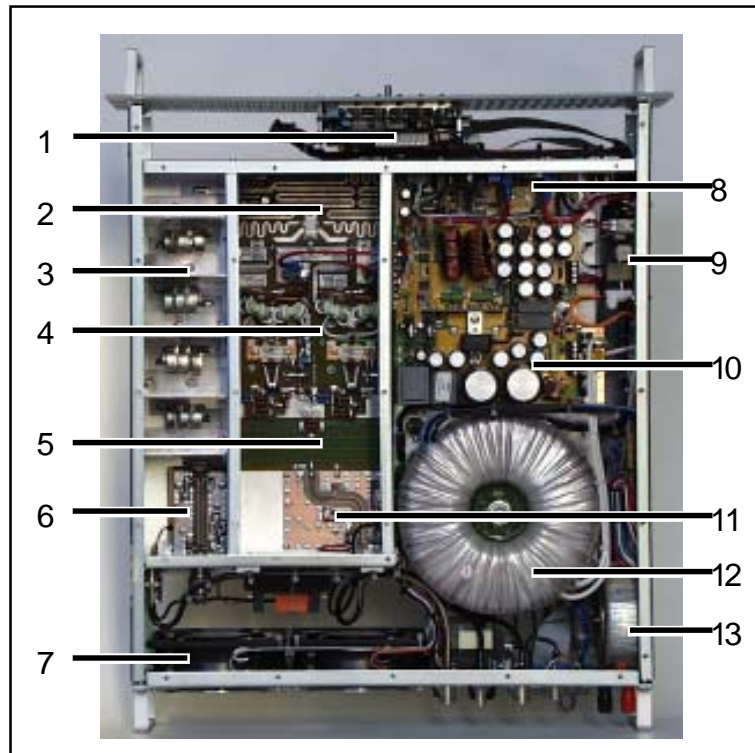

- [1] CPU
- [2] Wilkinson Combiner
- [3] Low-pass filter
- [4] Power amplifier Modules
- [5] Wilkinson splitter
- [6] Output directional coupler
- [7] Blowers
- [8] Bias Card
- [9] Soft Start Card
- [10] Switching power supply
- [11] Input directional coupler
- [12] Transformer (power)
- [13] Transformer (service)

8.1 PJ500M-C LCD with MN7000 Option

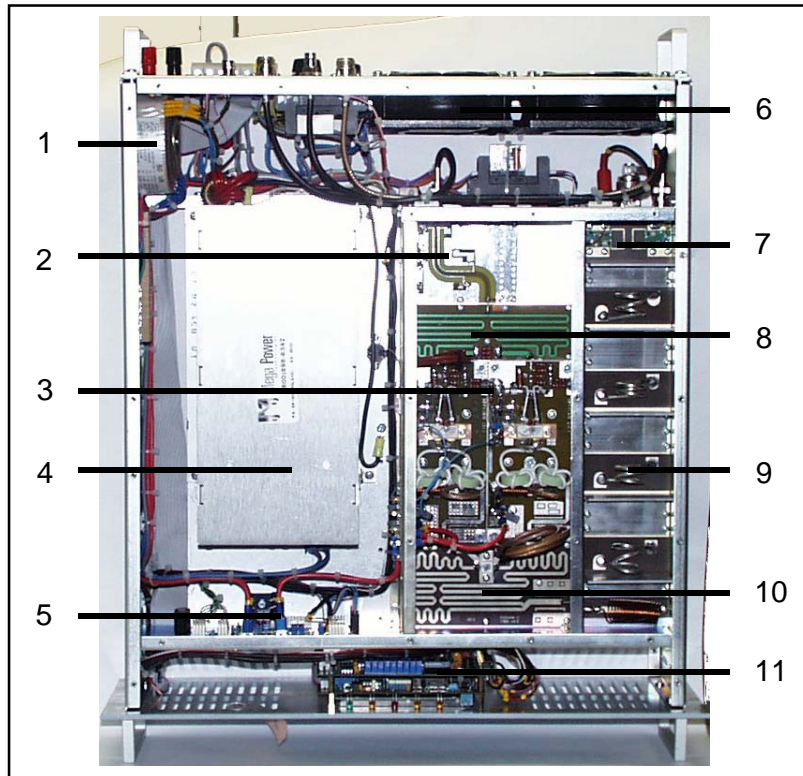

- [1] Transformer (service)
- [2] Input directional coupler
- [3] Power amplifier Modules
- [4] Switching power supply
- [5] Bias Card
- [6] Blowers
- [7] Output directional coupler
- [8] Wilkinson splitter
- [9] Low-pass filter
- [10] Wilkinson Combiner
- [11] CPU

8.2 Power supply

The power supply are housed in the left side of the amplifier. The Switching Power Supply is mounted on a heats that allows its cooling through forced ventilation.

Housed inside to the PJ500M-C there are two transformers, both having a selectable input for voltages of 110 and 220 Volt.

The first has one output, 61-0-61 Volt for Switching Power Supply.

The second has three outputs: 18-0-18 V, 0-15 Volt, C 0-15V, the output A drive the Alarms Card and the Soft Card, the outputs B and C supply the Control Section of Switching Power Supply.

Inside the Alarms Card a rectifying and stabilization circuit provides the +15 and -15 V needed by the electronics.

8.3 Soft Start

The soft-start card is a board placed on the left side of the amplifier.

This circuit imposes a resistive load when the amplifier is activated and excludes it after a certain delay. In this way, the current spikes due to the transformer at power-on are reduced.

8.4 Input directional coupler

The function of this circuit is to provide the measurement of the input power, that elaborated by the software for the protection of the amplifier. This card also hosts the temperature sensor, that is monitored by the software too.

8.5 RF Power Amplifier

The R.F. Power amplifier section is composed of the two power modules coupled with a Wilkinson Splitter and Combiner realized with "Strip Line Technology".

The four R.F. modules, splitter card and combiner card are housed in the top side of the equipment.

All R.F. section is mounted on a heat-sink that allows its cooling through forced ventilation.

Each module delivers 300W with 4-6W of drive and is supplied by an switching power supply.

The quiescent parameters of each module are:

VDC=50V Vgs=3.5V Idq=200mA

The active device employed is a Mosfet (the newer version uses SD2932, the older version uses BLF278).

8.6 Wilkinson Splitter and Combiner

Both the splitter and the combiner are realized in Strip-Line technology".

The Splitter Card is used to split the RF power of the exciter and provide half of it to each R.F. Power Amplifier module.

The Combiner Card is in turn used to combine the output power of the R.F. Power Amplifier modules to obtain the total rated power.

These two circuits guarantee equal phases of the power of each R.F. Power Amplifier module. A power resistor placed on each circuit is used to dissipate any power due to unbalancement of the power paths in case of fault of one of the modules.

8.7 Bias Card

This card has the function to control and if necessary to correct the polarization current of each Mosfet of the R.F. section.

It is also able to supply measurements as: currents, voltages for each R.F. amplifier module, total current and average voltage.

8.8 Low-pass Filter

This filter is housed in the right side of the equipment. Its role is to suppress the harmonic components generated by the amplifier under the levels required by regulations.

8.9 Output Directional Coupler

The function of this circuit is to provide the measurement of the forward and reflected output power.

8.10 CPU

This subsystem is composed by three cards: the CPU card, the display card and the analog section card.

This subsystem implements all the software functions (measurements, protection, control, data display, communications) described in the previous chapters.

8.11 Telemetry connector

The telemetry connector is a DB25 type one placed on the rear panel. This connector provides seven analog outputs, eight open-collector digital outputs and four digital inputs.

The pin assignment is given in the following table.

Pin N°	Descrizione	Tipo	Fondo scala
1	SWR interno	Uscita analogica	3,9 V a 1/2 W
2	Tensione Amplificatore di Potenza	Uscita analogica	3,9 V a 50 V
3	GND		
4	Potenza riflessa	Uscita analogica	4,3 V a 50 W
5	Interlock	Uscita OC	
6	Set 4	Uscita OC	
7	GND		
8	Comando "On"	Input	
9	Set 1	Uscita OC	
10	WAIT	Uscita OC	
11	Reset allarmi	Input	
12	OFF	Uscita OC	
13	Interlock	Input	
14	Temperatura	Uscita analogica	3,9 V a 100°
15	Corrente Amplificatore di Potenza	Uscita analogica	3,9 V a 20 A
16	Potenza diretta	Uscita analogica	4,3 V a 500 W
17	FAULT	Uscita OC	
18	Set 3	Uscita OC	
19	Potenza in ingresso	Uscita analogica	3,9 V a 20 W
20	Comando "OFF"	Input	
21	GND		
22	Set 2	Uscita OC	
23	LOC	Uscita OC	
24	+ Vcc		
25	ON	Uscita OC	

8.12 External telemetry card (optional)

This optional device is designed to interface to the telemetry connector of the PJ500M-C/LCD, and its main role is to give to the user a number of dry contacts related to the status of the amplifier. The contacts can be configured as normally open or closed, and are triggered by the four user settable thresholds plus LOC/REM, WAIT, FAULT, ON, OFF, INHIBIT.

The analog signals produced by the amplifier are replicated on a DB9 connector.

8.13 PFC Switching Power Supply (optional)

This optional module, replaces the assembly composed by the main transformer, the soft start board and the standard switching power supply. The data sheet of the module is included in the appendix of this manual.

Among the pros of this option are the active power factor correction (0.99), a better efficiency, and a reduction in weight of the machine.

The modified wiring diagram of the amplifier using this type of power supply is included in the technical appendix.

Appendix A **Piani di montaggio, schemi elettrici, liste componenti / Component layouts, schematics, bills of material/ Disposición de componentes, esquemas y lista de materiales**

Questa parte del manuale contiene i dettagli tecnici riguardanti la costruzione delle singole schede componenti il PJ500M-C LCD. L'appendice è composta dalle seguenti sezioni:

This part of the manual contains the technical details about the different boards of the PJ500M-C LCD. This appendix is composed of the following sections:

Esta parte del manual contiene los detalles técnicos a cerca de las diferentes tarjetas del PJ500M-C LCD. Este apéndice está compuesto de las siguientes secciones:

Description	RVR Code	Vers.	Pages
Wiring Diagrams		1.12	8
Wilkinson "2-Way" Splitter Card	PJ500M-CSPL-IN	1.1	4
R.F. Power Amplifier Module	PJ1KRF	1.4	4
Wilkinson "4-Way" Combiner Card	PJ500M-CCMB-OUT	1.2	4
Input Directional Coupler Card	CSMPIPJ5MCL	1.2	4
LPF+MEAS		1.1	4
	CSB1		
	CSBLFPJ1KM		
	CSLPFPJ1KM		
	CSDCLPFPJ1KM		
Output Directional Coupler Card	DRCPPJ1KM (Before January 2002)	1.1	4
Low Pass Filter	PJ1KLPF (Before January 2002)	1.1	4
Switching Power Supply	PSSW5020B	1.2	6
Soft Start Card	CSSOFTS	1.1	4
Bias Control Card (New Version)	CSBIASPJ5M01	1.3	6
Bias Control Card (Old Version)	CSBIASPJ5MCL01	1.1	4
CPU Section e Protection Card	SLPROTPJ-HCL	1.0	8
External Telemetry Card	CSPWRGDPSS01	1.1	4
Scheda Viti Passanti	CSFILPS	1.0	4
Scheda filtraggio EMI	CSADPCNP RTPJ	1.0	4

*Pagina lasciata intenzionalmente in bianco
This page intentionally left blank*

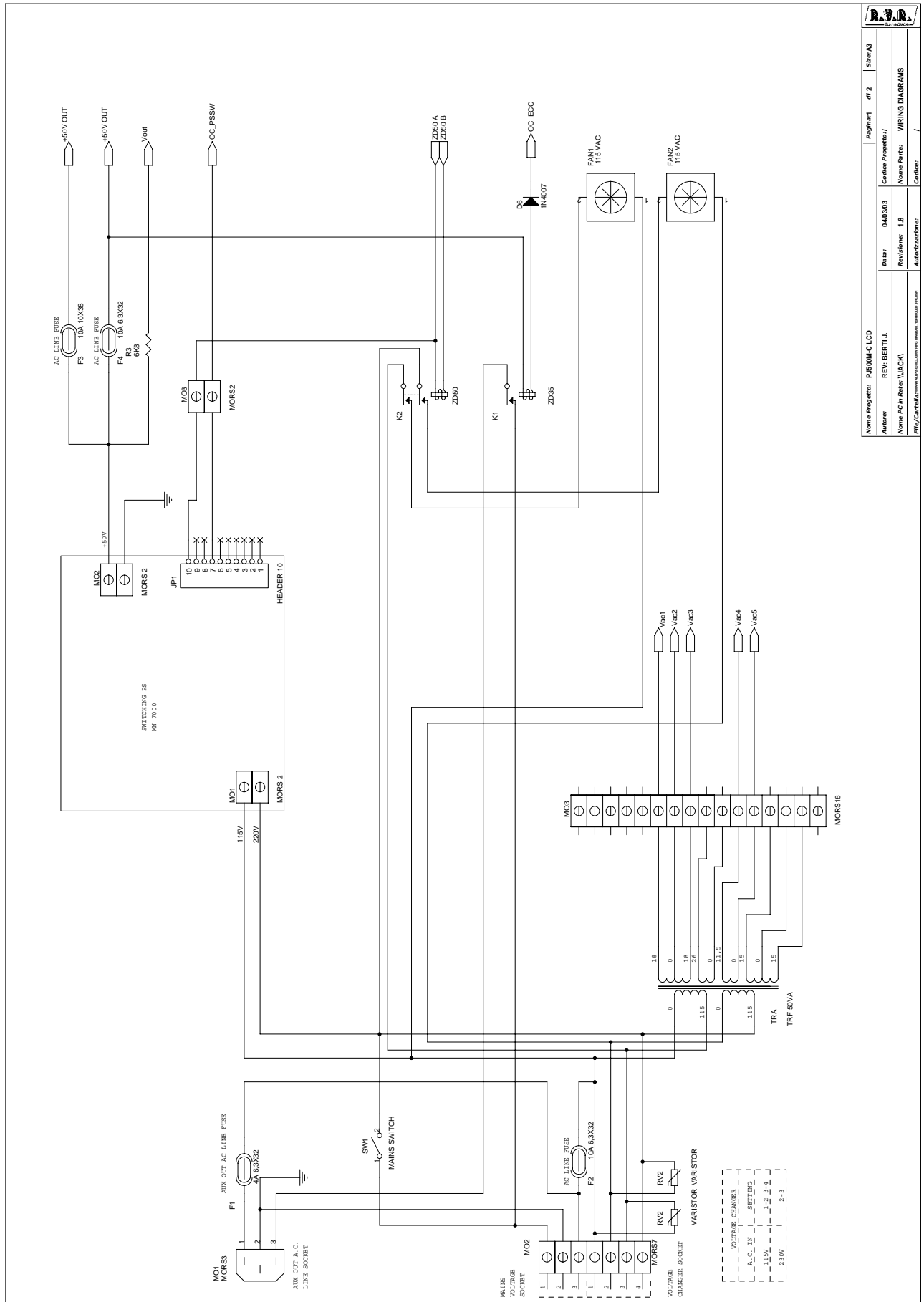

Nome Progetto: PJ500M-C-LCD		Page/nr:1	di:2	Sheet:3
Autore: REV: BERTI J.	Codice Progetto: /			
Nome PC in Rete: \AACK\	Nome Printer: WIRING DIAGRAMS			
File/Caratteristiche:\AACK\PROJET\COMPARA\NOMI\REV0000.DWG	Revisione: 1.8			
		Autorezzazione:		
		Contact: /		

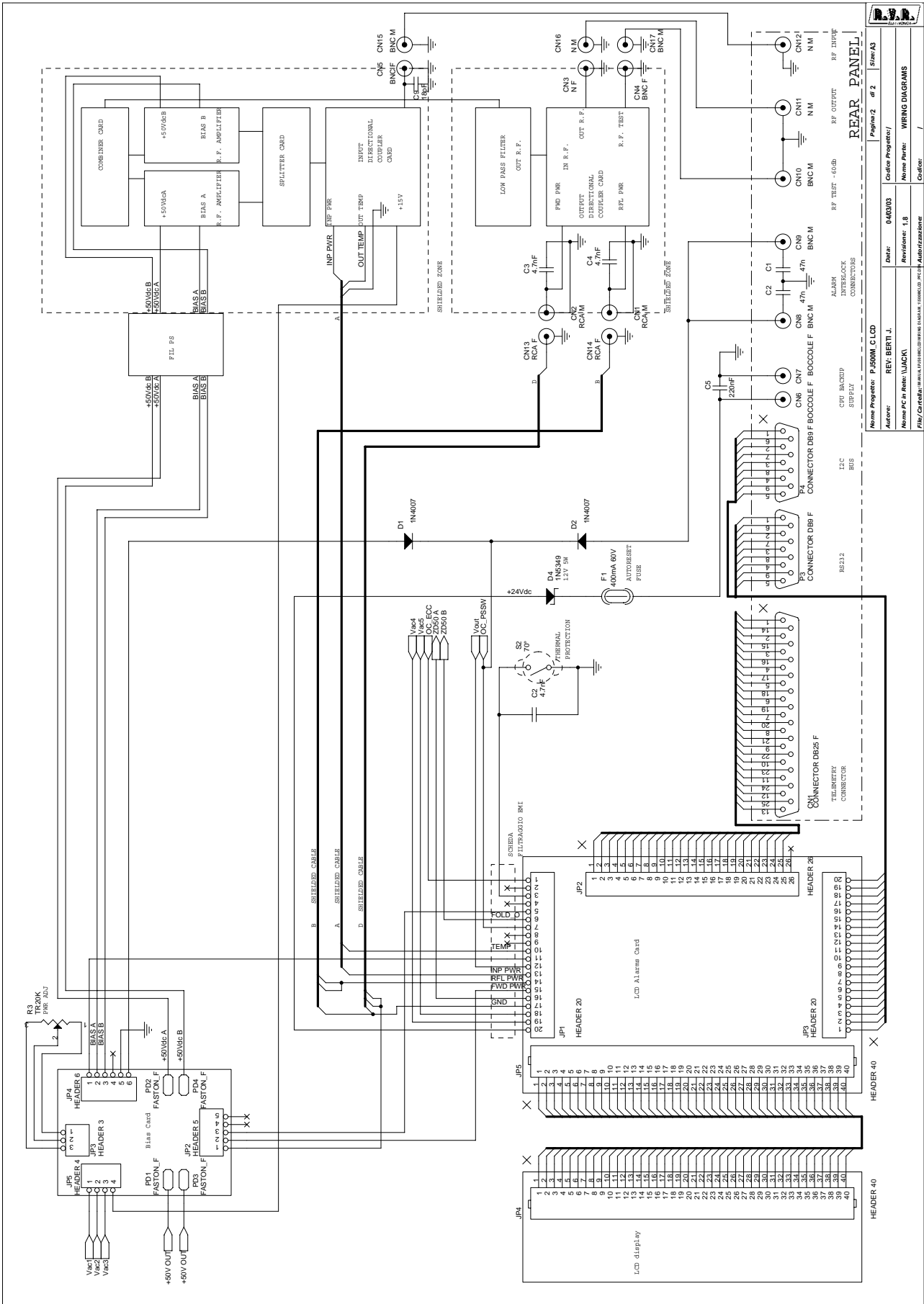

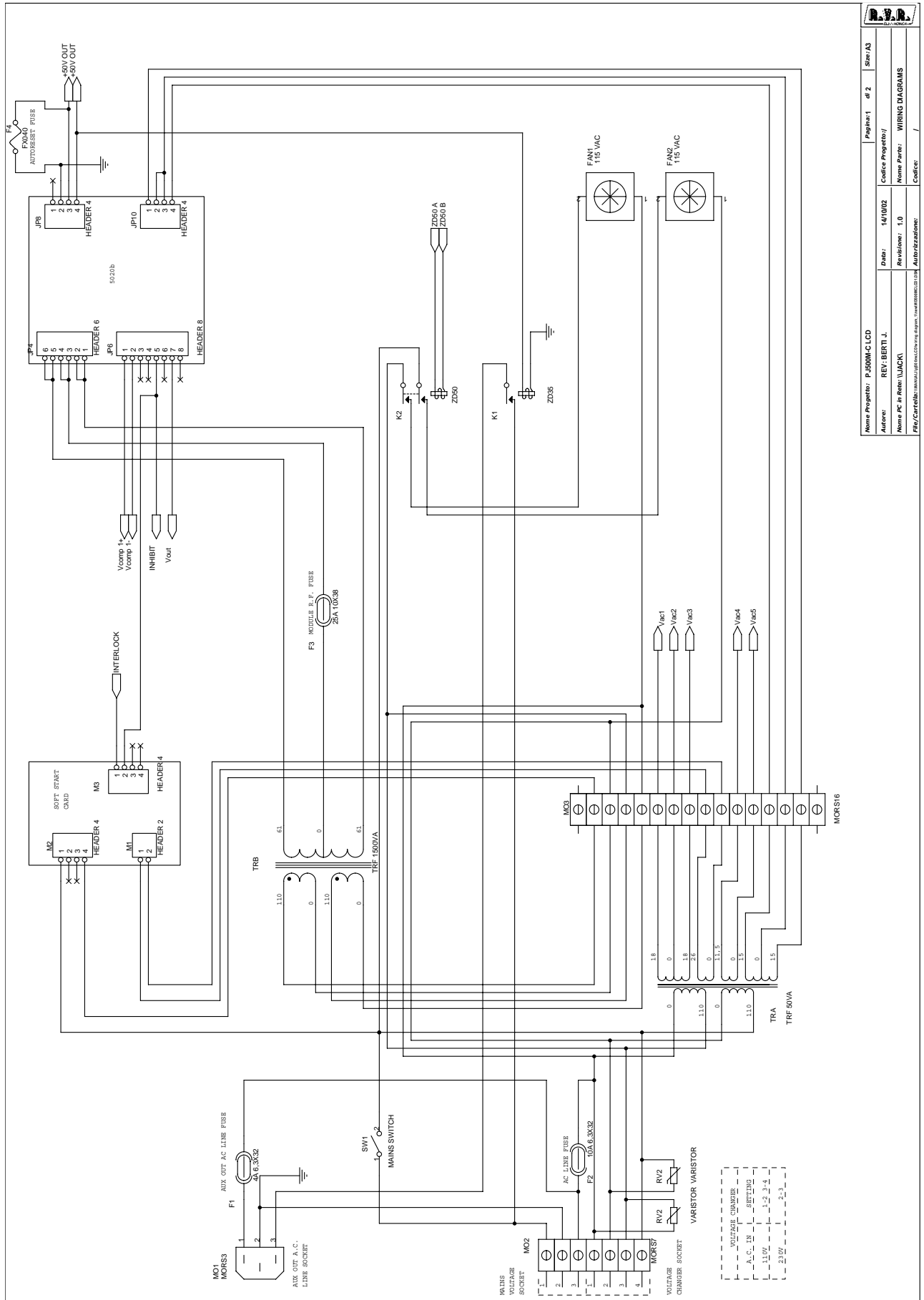

R.V.R. ELETTRONICA	
Nome Progetto: PJ500M-C.LCD	Sheet: 13
Autore: REV: BERTI J.	14/10/02
Nome PC in Rete: \LACK	Revisione: 1.0
Autore/Revisione: /	
Nome File: WIRING DIAGRAMS	
Codice:	

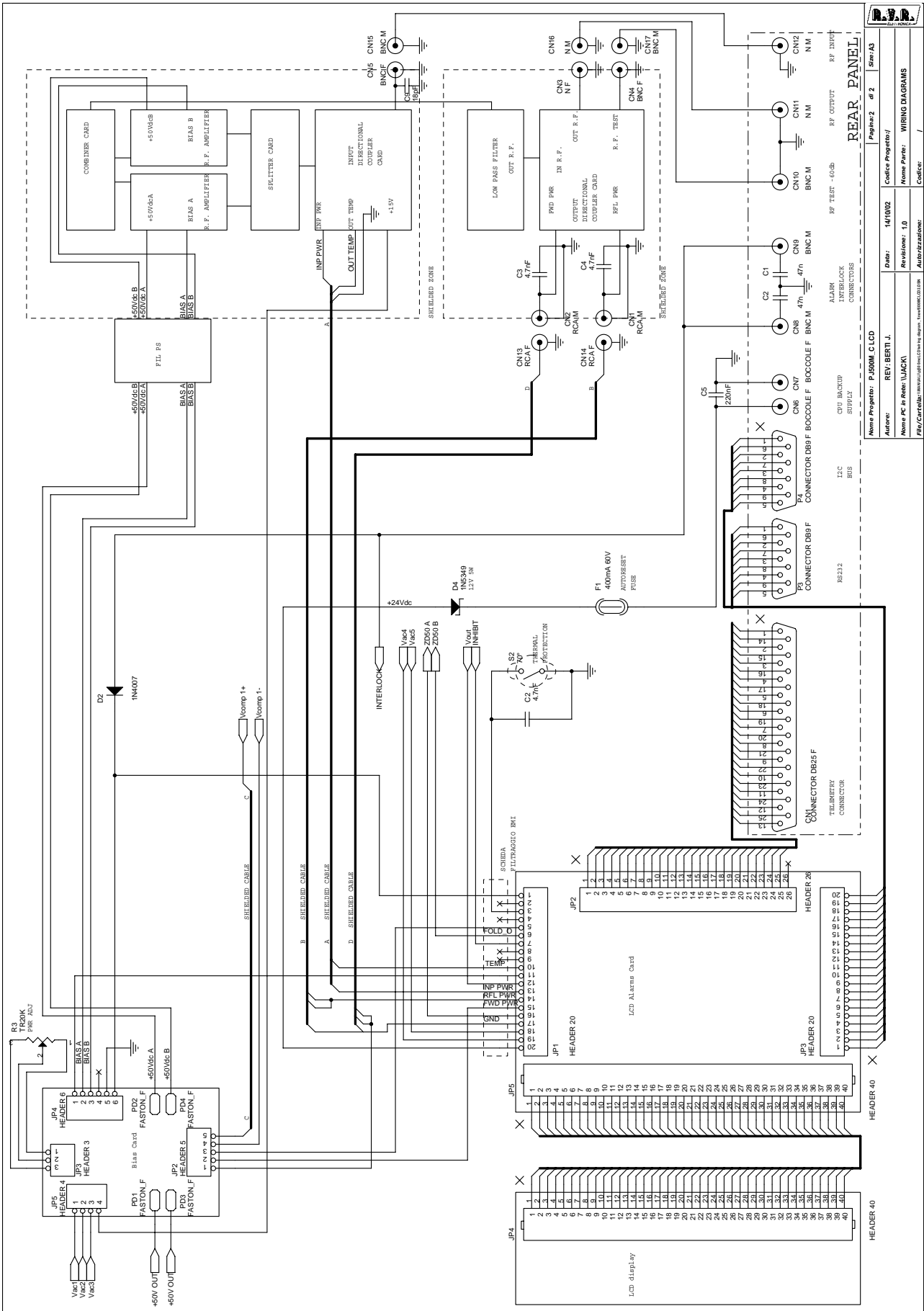

R.V.R. ELETTRONICA	
Nome Progetto: P.500M.C.LCD	Revisione: 1.0
Autore: REV. BERTI J.	Autores: /
Nome PC in Rete: UACXI	Nome Progetto: WIRING DIAGRAMS
Data: 14/10/02	
Codice Progetto: /	
Page: 2 of 2	
Size: A3	

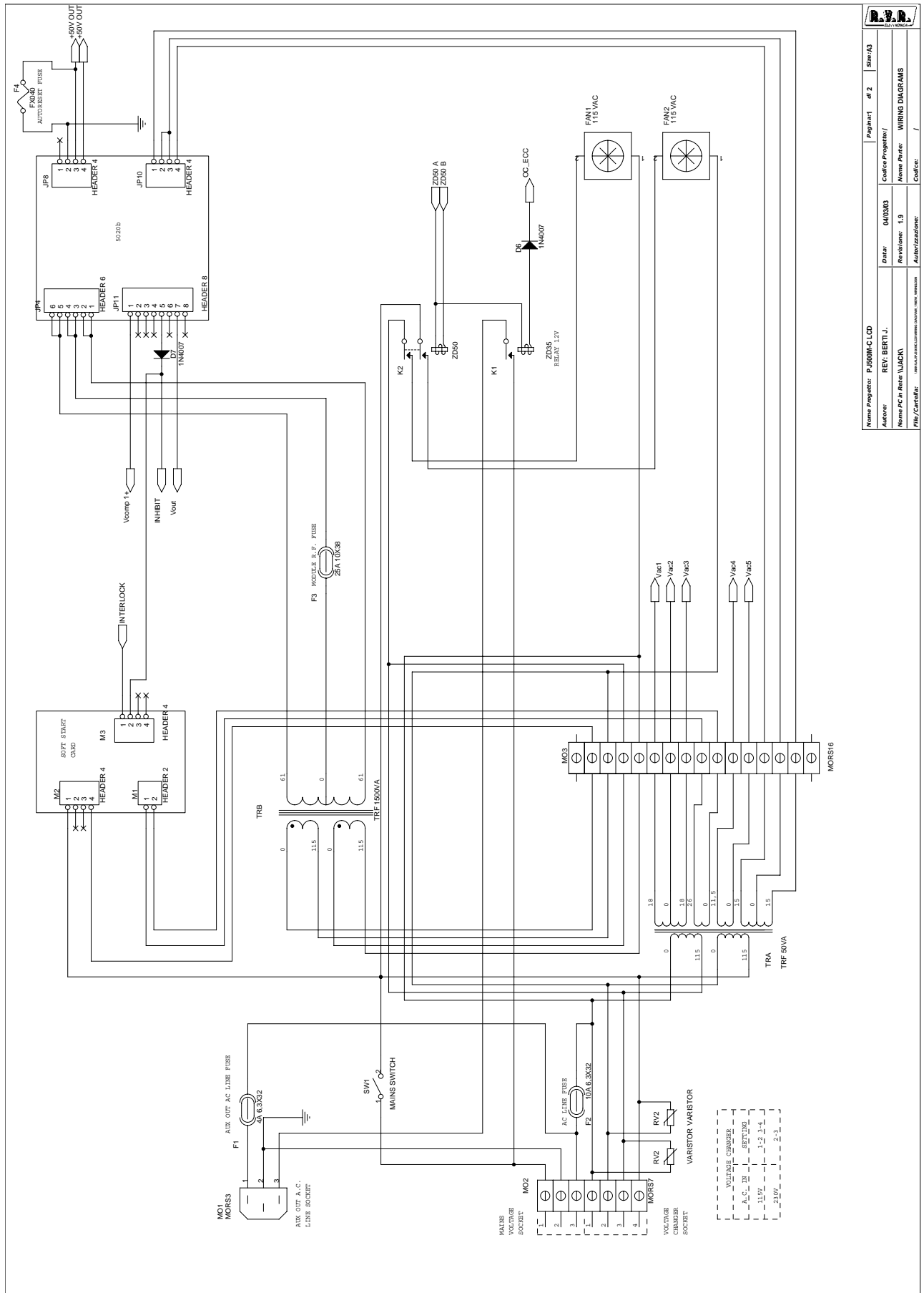

Nome Progettista:	PJ500M-C LCD	Page/total:	d/2	Rev/A3
Autore:	REV. BERTI J.	Califica Progettista/		
Nome PC in Rete:	LUACKI	Data:	04/03/03	
File/Caratteri:		Revisione:	1.9	
		Autore/Revisione:		
		Nome Proiect:	WIRING DIAGRAMS	
		Califica:		

Versione precedente, solo per riferimento
Former version, for reference only

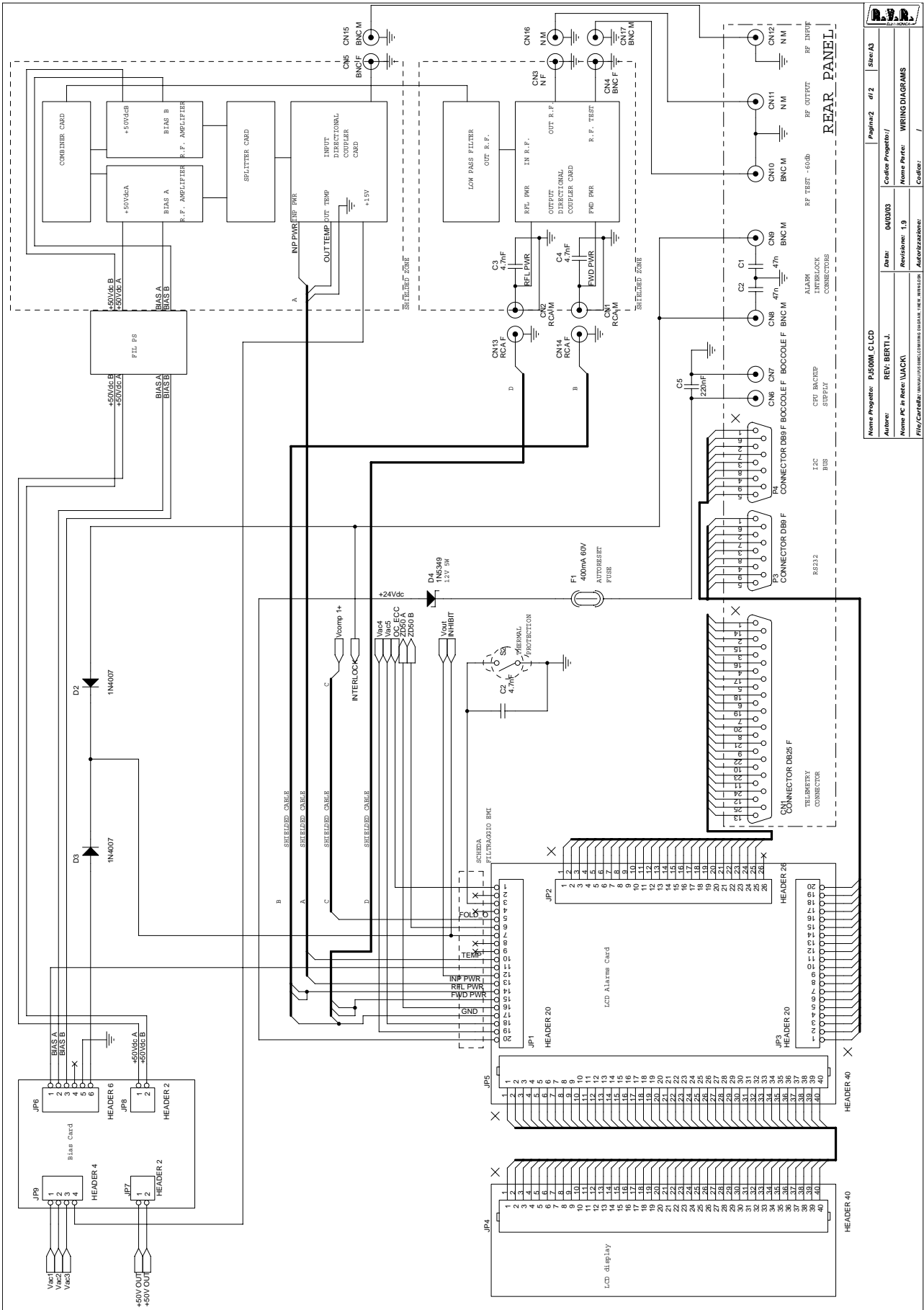

R.V.R. ELETTRONICA	
Nome Progetto: PJ500M-C LCD	Stampa: 2 of 2
Autore: REV. BERTI J.	Data: 04/03/03
Nome P.c.: ALDO VUCCI	Nome Progetto: WIRING DIAGRAMS
File/Controllo: MANUALE DI CONTROLLO DISPLAY PER WIRELESS	Autore/Stampa: 1/9
	Coef.: /

Versione precedente, solo per riferimento
Former version, for reference only

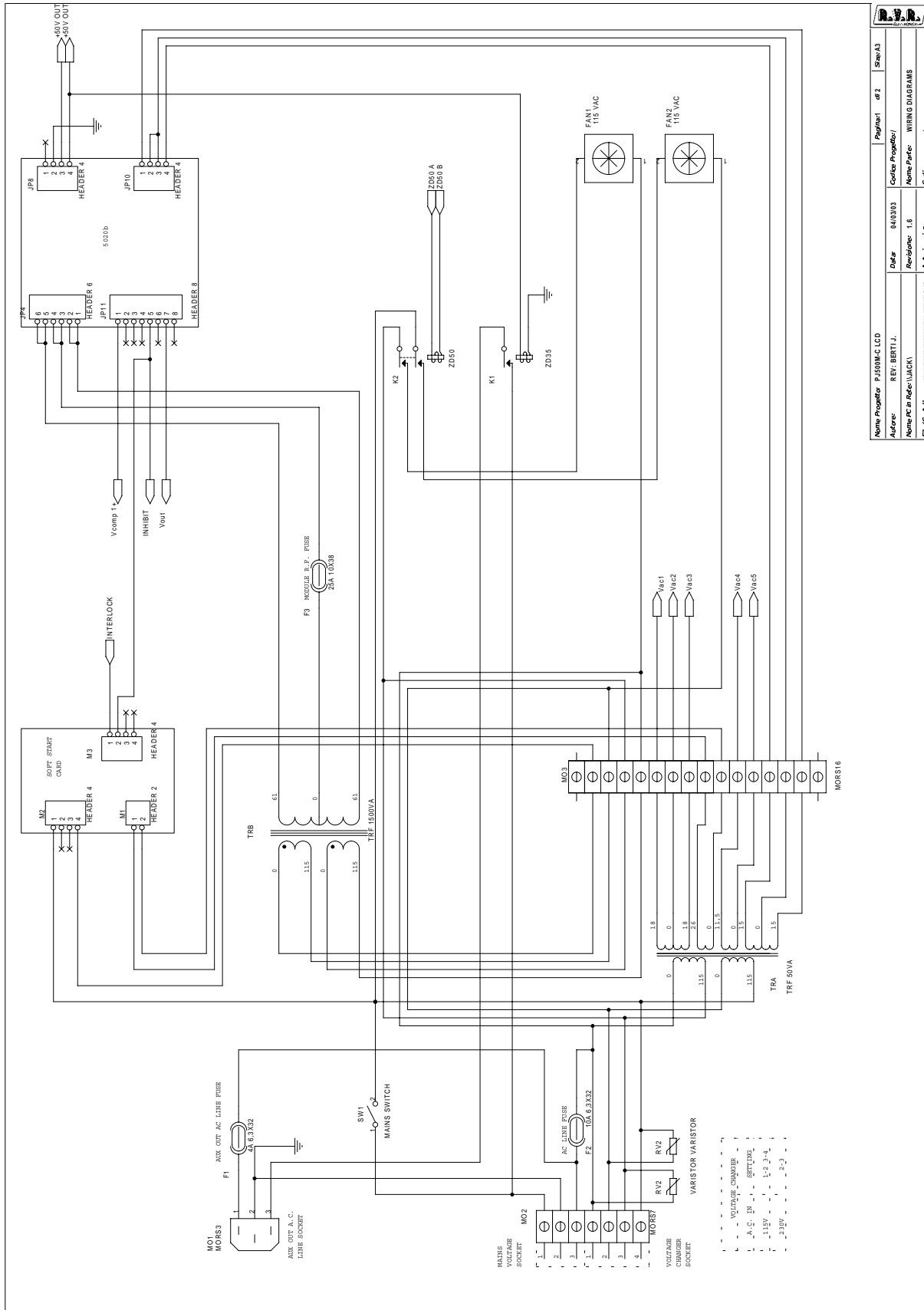

Nome Progetto	PJ500M-C LCD	Page/nr	di 2	Step	A3
Autore	REV. BERTI L.	Data	04/03/03	Carta Progettazione	
Nome PC in Rete	YUACK1	Revisione	1.6	Nome File	WIRING DIAGRAMS
File/Carta/Dir.		Autore/autore		Conf/col.	/

Versione precedente, solo per riferimento
Former version, for reference only

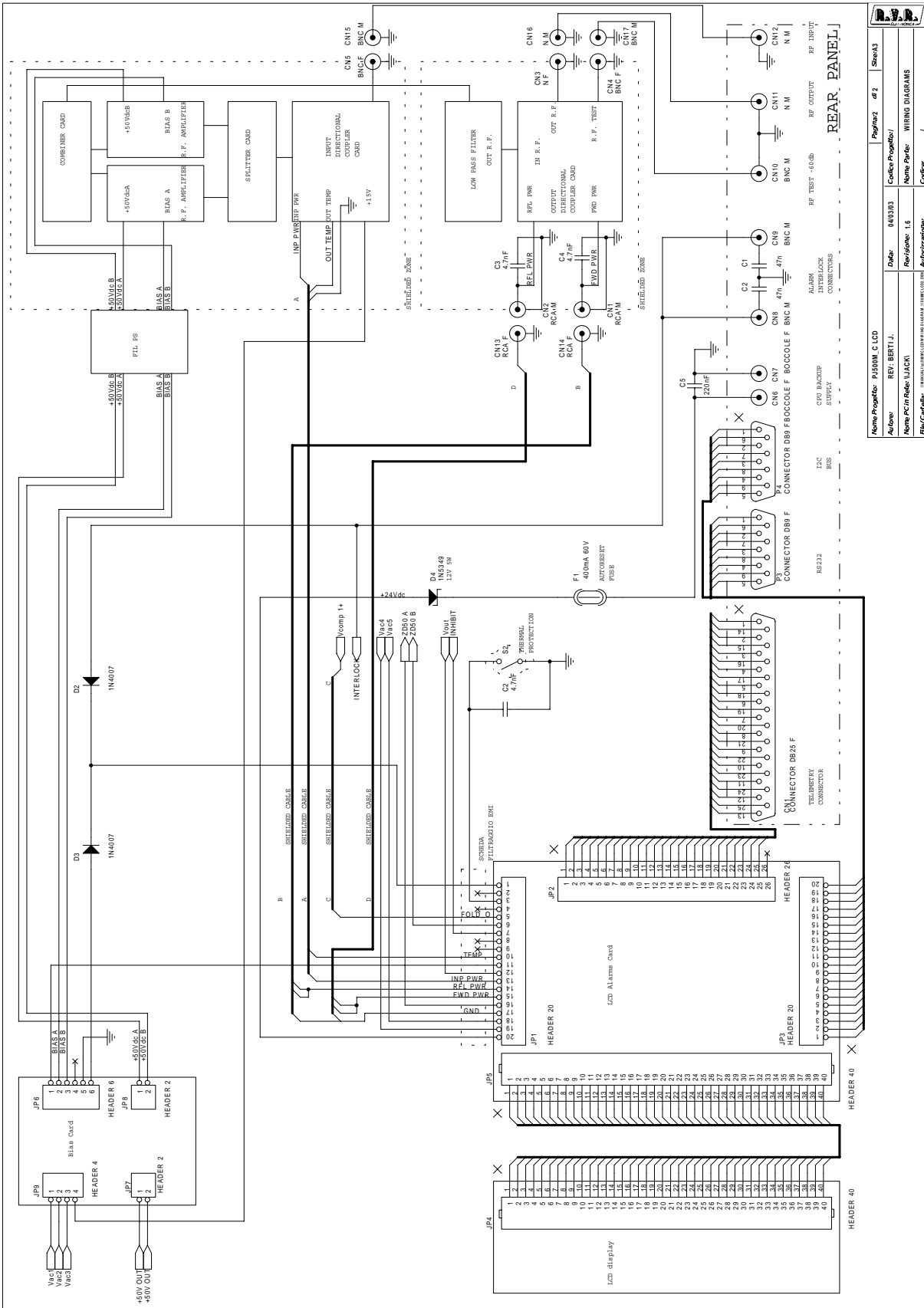

Nome Progetto	PJ500M-C LCD	Page no.1	#1	Scop.1A
Autore	REV. BERTI J.	Numero	04/03/03	Codice Progetto
Nome PC in Rete	W-LACK	Revisione	1.6	Nome Parte
Rev./Codice	10/04/03	Autore	Alberto Bertoni	Codice

Versione precedente, solo per riferimento
Former version, for reference only

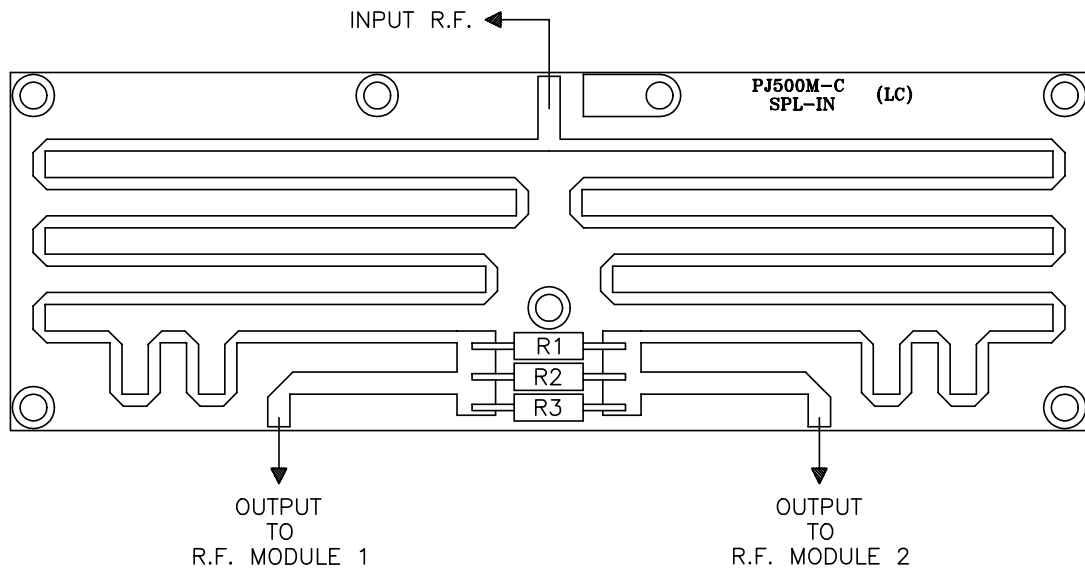

DENOMINAZIONE
Wilkinson "2-Way" Splitter Card Component Layout / Piano di Montaggio

DISPOSITIVO

SEMILAVORATO

DISEGNATO

DISEGNO

MATERIALE

D'Alessio D. li 10/02/97

TRATTAMENTO

SCALA

TAVOLA n di

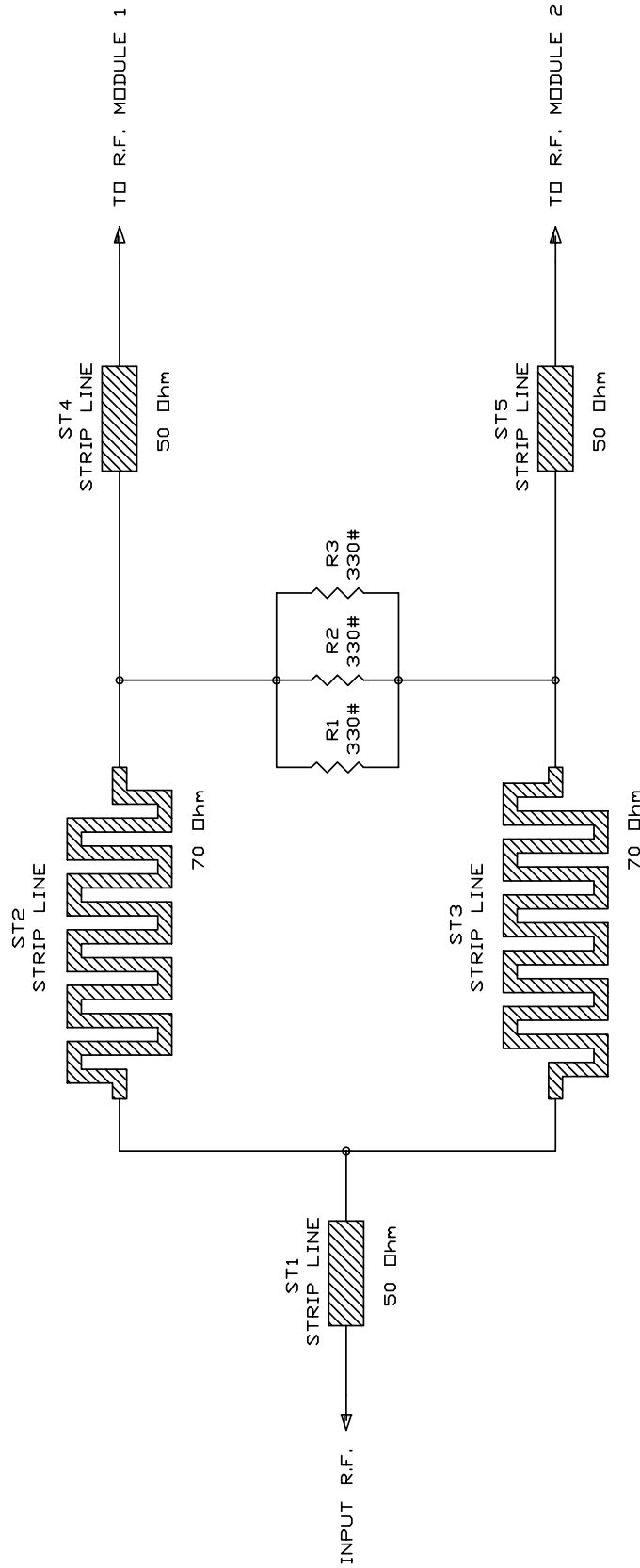

R.V.R. Elettronica S.r.l. (Bo)

Title: Wilkinson "2-Way" Splitter Card

Size: Document Number

A4

Date: February 10, 1997 Sheet

of

REV

Splitter Card	Bill of Materials				
Item	Qty	Reference	Part DESCRIPTION	PART ORDER CDE	
1	3	R1,R2,R3	330# RESISTOR 2W		
2	5	ST1,ST2,ST3 ST4,ST5	STRIP LINE		

Pagina lasciata intenzionalmente in bianco
This page was intentionally left blank

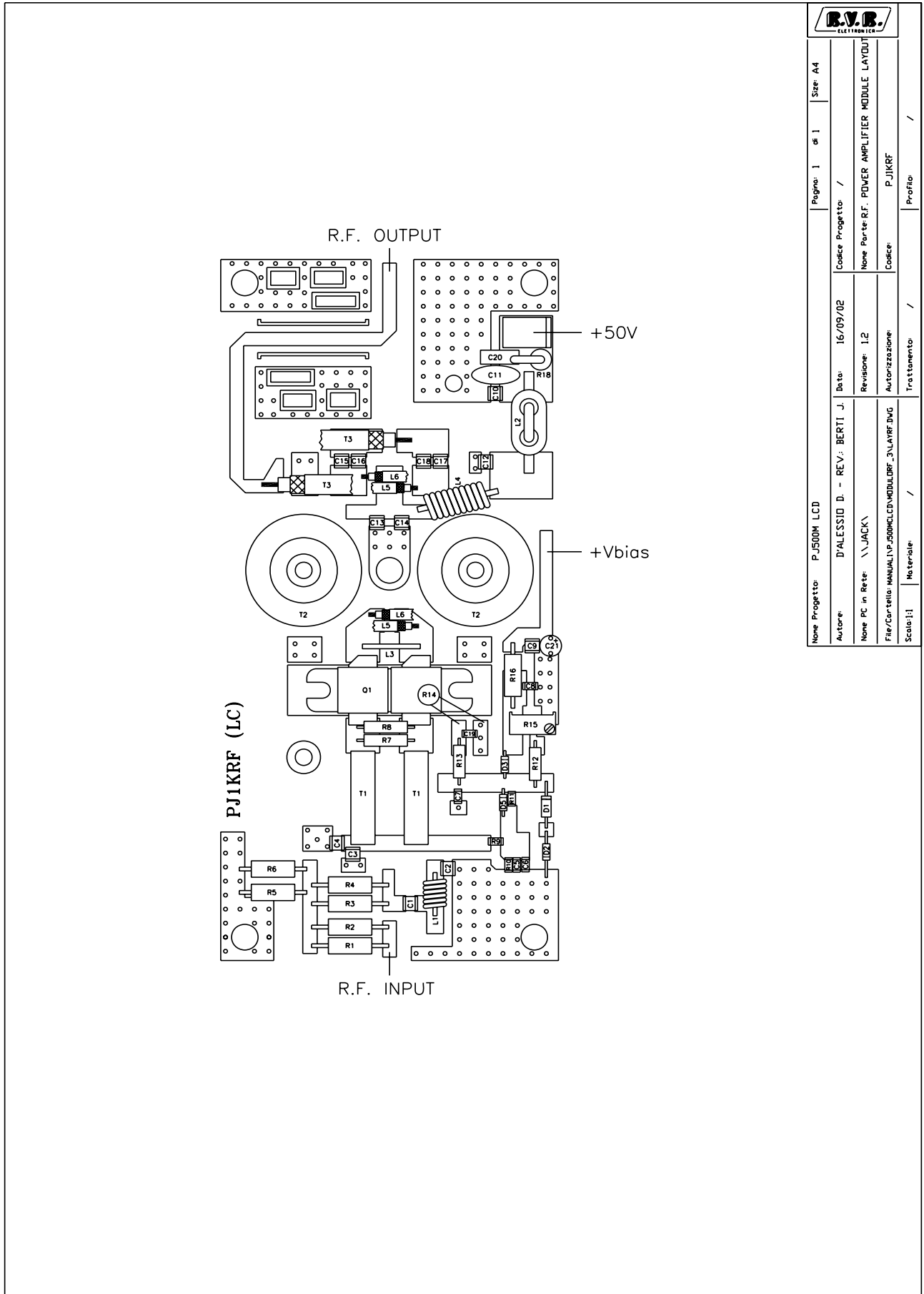

None Progetto: PJ500M LCD		Pagina 1	di 1	Size: A4
Autore:	D'ALESSIO D. - REV.: BERTI J.	Codice Progetto: /		
None PC in Rete:	\\JACK\	Data:	16/09/02	
File/Carta:	MANUALI\PJ500M\LCD\MODULE_3LAYER.BUG	Revisione:	1.2	
Scale: 1:1	Materiali: /	Autore:	PJ1KRF	
		Trattamento:	/	
		Profilo:	/	

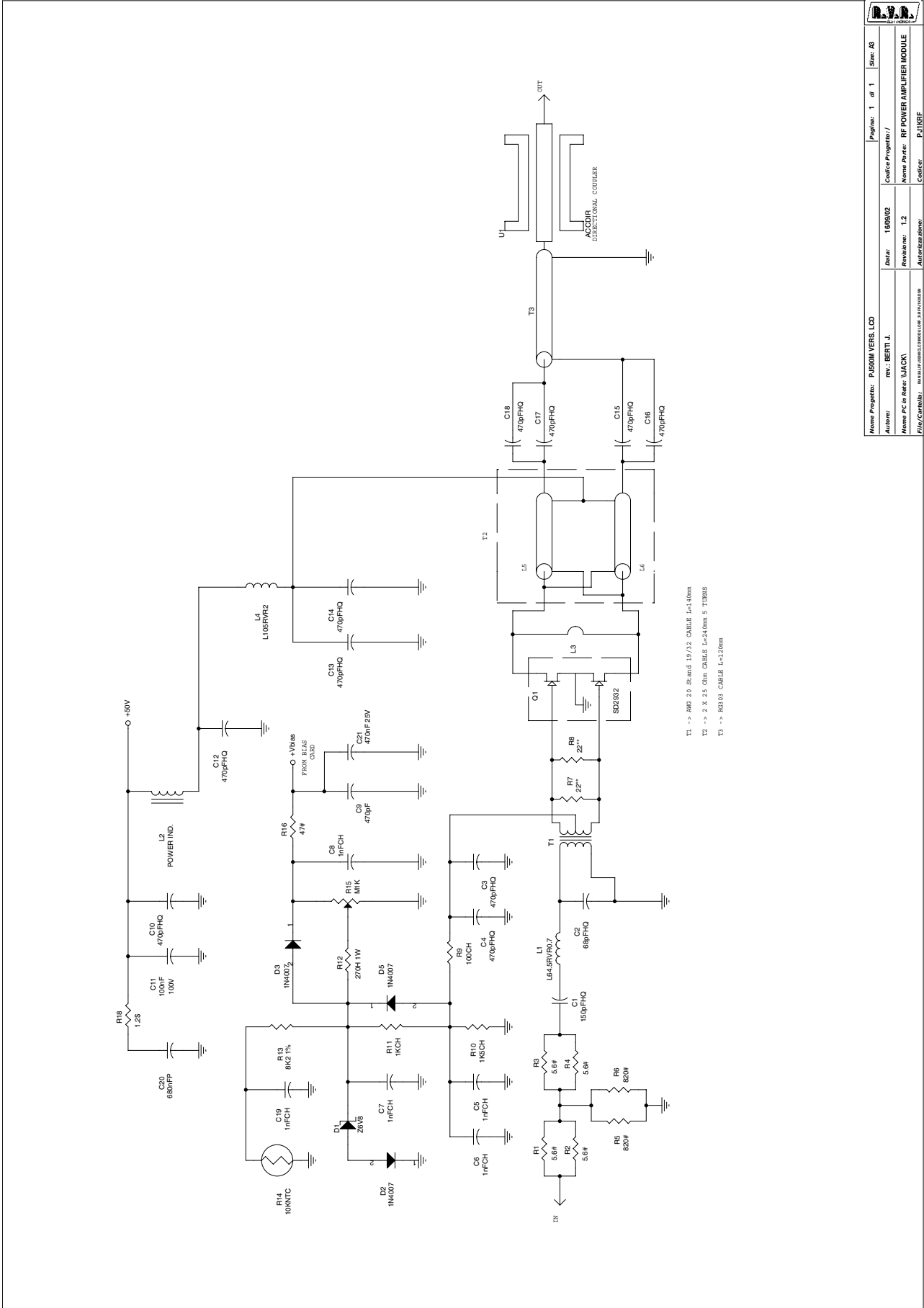

Nome Progetto: PJ500M VERS. LCD		Pagina: 1 di 1		Sce: A3	
Autore: RW: BERTI J.		Codice Progetto: /			
Nome PC in Rete: WACKI		Revisione: 1.2		Nome Parte: RF POWER AMPLIFIER MODULE	
File/Cat/Bibli: MANUALE PER IL MODULO AMPLIFICAZIONE		Autore/Revisione: P.J.KRF			

Item	Quantity	Reference	Part	DESCRIPTION	PART ORDER CODE
1	1	R18	1.2\$	RESISTOR 5W	
2	4	R1,R2,R3,R4	5.6#	RESISTOR 2W	
3	2	R7,R8	22**	RESISTOR 1W 5%	
4	1	R16	47#	RESISTOR 2W	
5	1	R9	100CH	CHIP RESISTOR	
6	1	R12	270H 1W	RESISTOR 1W	
7	2	R5,R6	820#	RESISTOR 2W	
8	1	R11	1KCH	CHIP RESISTOR	
9	1	R10	1K5CH	CHIP RESISTOR	
10	1	R13	8K2 1%	RESISTOR 1/4W 1%	
11	1	R14	10KNTC	NTC	
12	1	R15	M1K	TRIMMER MULTIGIRI	
13	1	C2	68PFHQ	HIGHT Q CAPACITOR	
14	1	C1	150PFHQ	HIGHT Q CAPACITOR	
15	11	C3,C4,C10,C12,C13,C14, C15,C16,C17,C18,C9	470PFHQ	HIGHT Q CAPACITOR	
16	5	C5,C6,C7,C8,C19	1NFCH	CERAMIC CHIP CAPACITOR	
17	1	C11	100NF	CERAMIC CAPACITOR	
18	1	C20	680NFP	POLIESTER CAPACITOR	
19	1	L2	POWER IND.	RF BINOC. CHOCKE	
20	1	L1	L64.5RVR0.7	6 SP DIA 4.5 RAME SMAL 0.7mm	
21	1	L4	L105RVR2	10 SP DIA 5 F 2mm	
22	1	L3	BU6012RVR2	BOB L60MM D12 FILO ARG 2MM	
23	1	T1	4:1	TRASF. RF. CAVO 25 OHM	
24	1	T3	RG303	COAX CABLE RG303	
25	2	L5,L6	RG316-25	CAOX CABLE RG316 25 Ohm	
26	3	D2,D3,D5	1N4004	SILICON DIODE 400V	
27	1	D1	1N5342B	SILICON DIODE	
28	1	Q1	SD2932	VHF PUSH-PULL POWER MOS	
29	1	C21	470nF 25V	ELECTROLITIC CAPACITOR	

Pagina lasciata intenzionalmente in bianco
This page was intentionally left blank

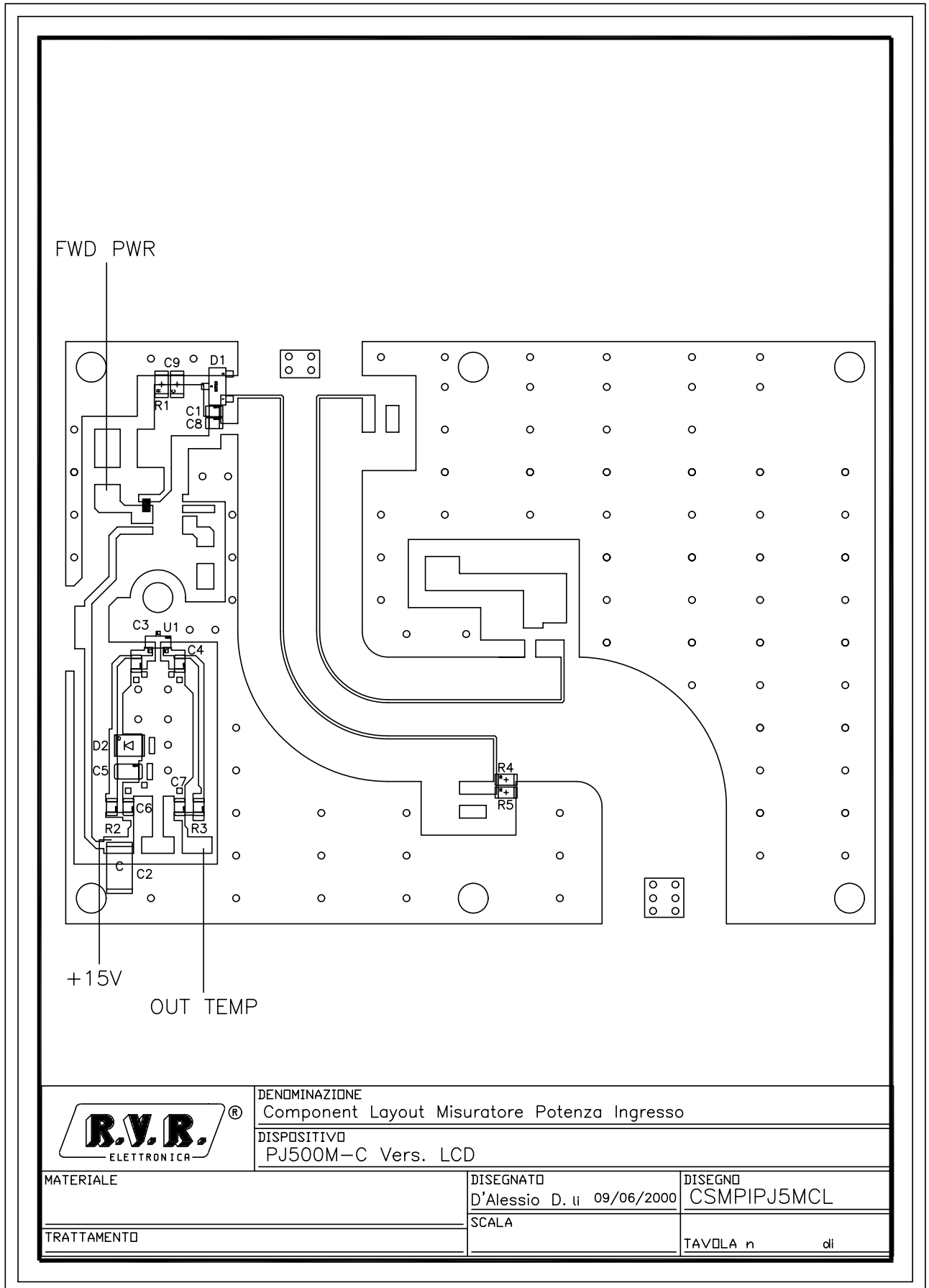

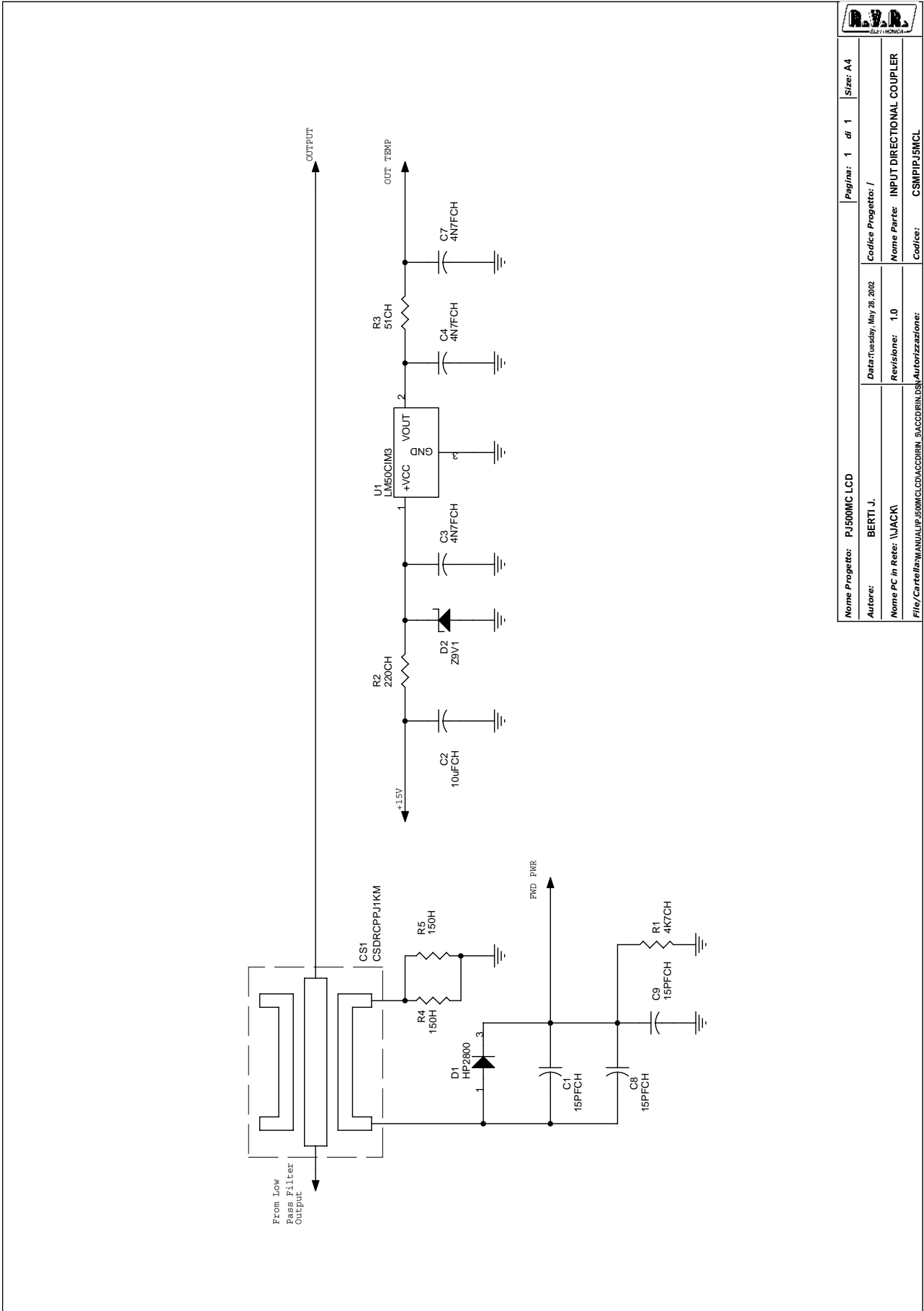

Nome Progetto: PJ500MC LCD		Pagina: 1 di 1		Size: A4
Autore: BERTI J.		Codice Progetto: /		
Nome PC in Rete: \JACKI		Data: Tuesday, May 28, 2002	Nome Parte: INPUT DIRECTIONAL COUPLER	
File/Carte/Manuali/PJ500MCLCD/ACDRIN_DS/ACDRIN_DS/		Revisione: 1.0	Codice: CSMPIPJ5MCL	

CSMPOPJ5MCL Item	Bill Q.ty	Of Materials Reference	Part	DESCRIPTION	Page	1
1	1	R1	4K7CH	CHIP RESISTOR 0805		
2	1	R2	220CH	CHIP RESISTOR 0805		
3	1	R3	51CH	CHIP RESISTOR 0805		
4	2	R4, R5	150H	CHIP RESISTOR 0805		
5	3	C1, C8, C9	15PFCH	CHIP RESISTOR 0805		
6	1	C2	10uFCH	16V TANTALIUM CHIP CAPACITOR		
7	1	C5	470NFCH	CHIP CAPACITOR 1206		
8	4	C3, C4, C6, C7	4N7FCH	CHIP CAPACITOR 0805		
9	1	D1	HP2800	DIODE SMD SOT23		
10	1	D2	Z9V1	ZENER DIODE		
11	1	U1	LM50CIM3	TEMPERATURE SENSOR		
12	1	C9	6P8FCH	CHIP CAPACITOR HQ		

Pagina lasciata intenzionalmente in bianco
This page intentionally left blank

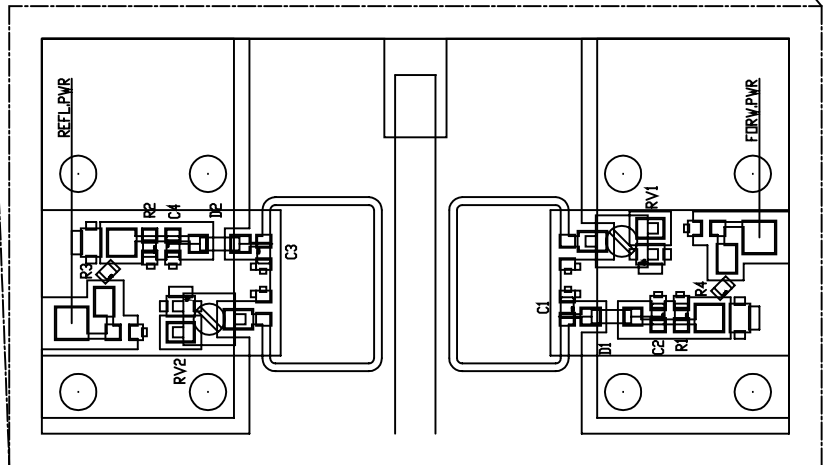
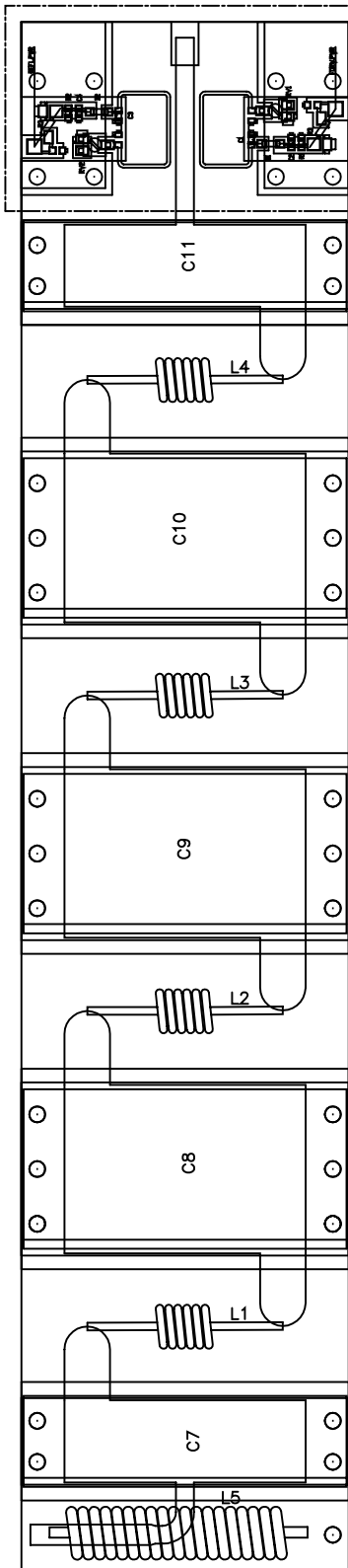

Nome Progetto: PJ500M_C vers. LCD		Foglio: 1 di 1		Size: A3
Autore: MAURO U. - REVI - BERTI J.	Data: 18/04/03		Codice Progetto: /	
Nome PC in Rete: \\\JACK\	Revisione: 2.2		Nome Parte: LAY PMS PL. TER + MASSA METR	
File/Cartelle: \MATERIALI\PJ500M-C\REV1_LPF+MEAS_2.DWG	Autore/Revisione: LPF+MEAS		Codice: LPF+MEAS	
Scala: /	Materiale: /		Trattamento: /	
			Profilo: /	

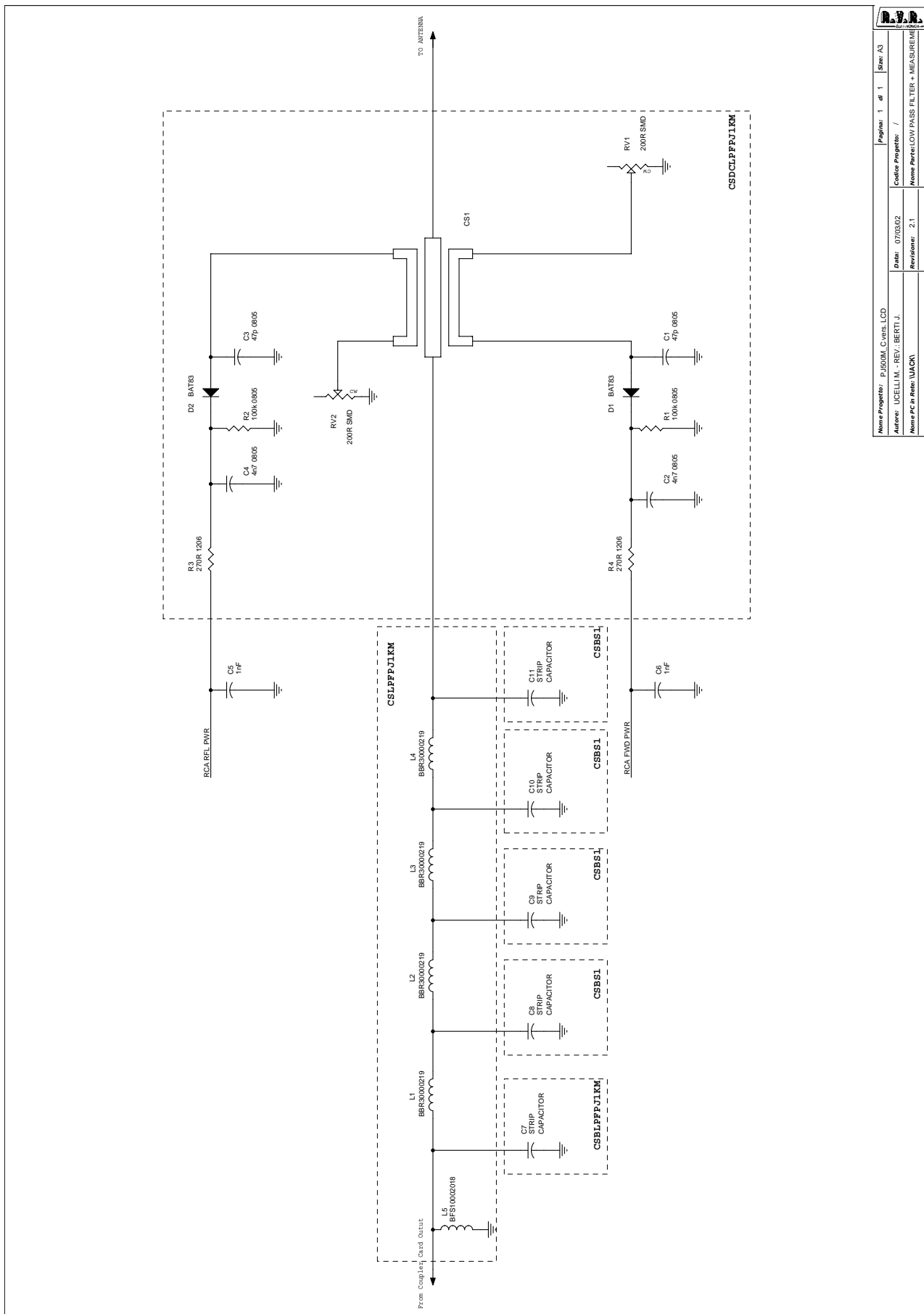

Nome Progetto: PJ500M_C.vers.LCD	Page: 1 di 1
Autore: UCCELLI M. - REV.: BERTI J.	Draw: 07/03/02
Nome PC in Rete: UACN	Revisione: 2.1
File: C:\dat\p\ANALISI\PC\500M\C\500M\LPT\TESTING\LPF\MEAS	
Codice Progetto: /	
Nome Partec LOW PASS FILTER + MEASUREME	
Codice: LPF+MEAS	

Item	Q.ty	Reference	Part
1	1	L5	BFS10002018
2	1	CS1	CSDRCPPJ1KM
3	2	C3, C1	47p 0805
4	2	C4, C2	4n7 0805
5	2	C5, C6	1nF
6	2	C7, C11	27pFTFL
7	3	C8, C9, C10	54pFTFL
8	2	D2, D1	BAT83
9	4	L1, L2, L3, L4	BBR30000219
10	2	RV2, RV1	200R SMD
11	2	R2, R1	100k 0805
12	2	R3, R4	270R 1206

Pagina lasciata intenzionalmente in bianco
This page was intentionally left blank

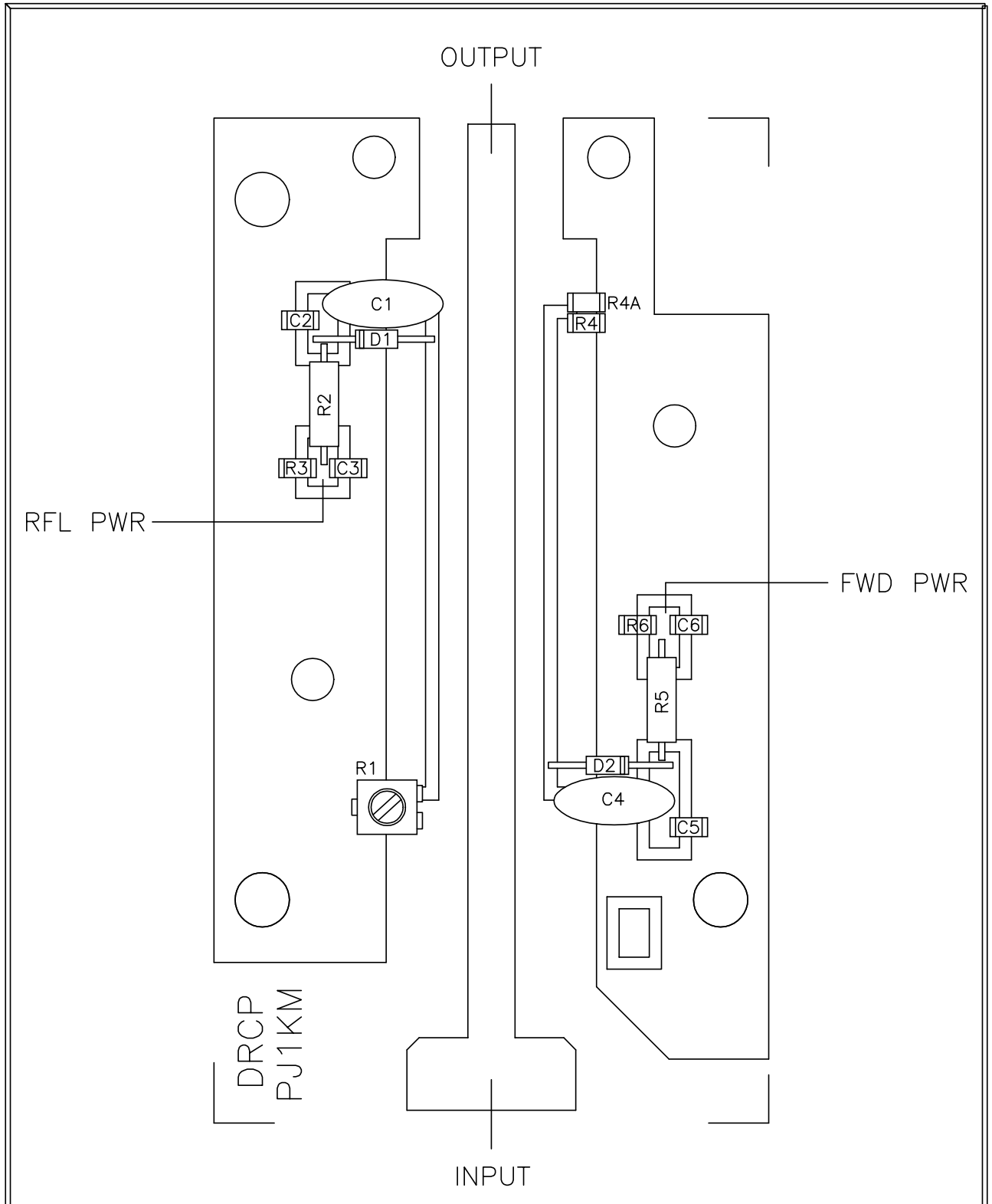

	DENOMINAZIONE	
	Directional Coupler Card Component Layout / Piano di Montaggio	
	DISPOSITIVO	
SEMILAVORATO	DISEGNATO	DISEGNO
MATERIALE	D'Alessio D.ii 12/08/98	
TRATTAMENTO	SCALA	TAVOLA n di

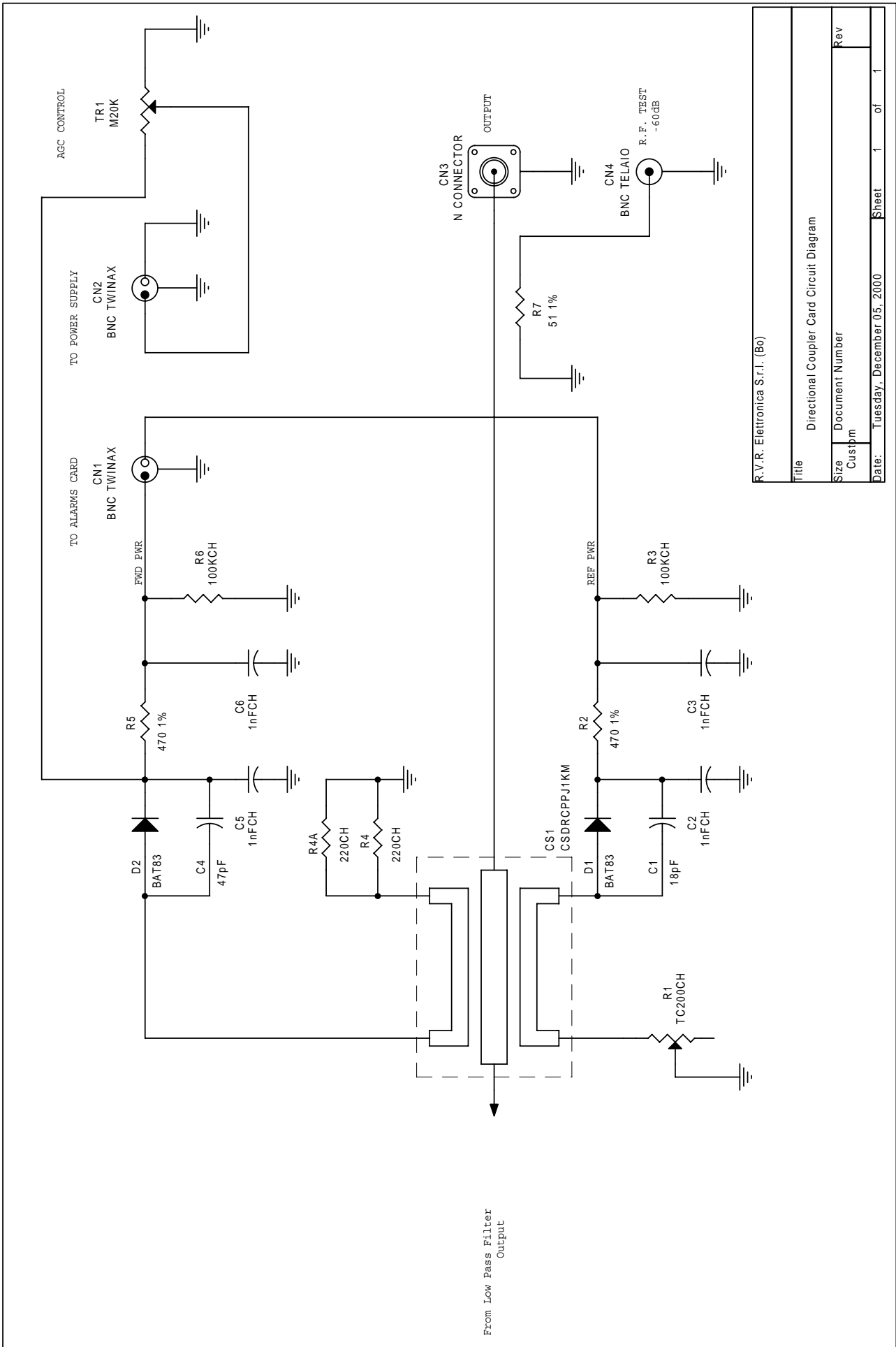

Item	Quantity	Reference	Part	DESCRIPTION	PART ORDER CODE
1	1	R7	51 1%	RESISTOR 1/4W 1%	
2	2	R4A, R4	220CH	CHIP RESISTOR	
3	2	R2, R5	470 1%	RESISTOR 1/4W 1%	
4	2	R3, R6	100KCH	CHIP RESISTOR	
5	1	R1	TC200CH	TRIM.REG.VER.CERMET SMD	
6	1	TR1	M20K	TRIMMER MULTIGIRI	
7	1	C1	18PF	CERAMIC CAPACITOR NPO	
8	1	C4	47PF	CERAMIC CAPACITOR NPO	
9	4	C2, C3, C5, C6	1NFCH	CERAMIC HIGH Q	
10	1	CN4	BNC TELAIO	CONN. BNC A TELAIO	
11	2	CN1, CN2	BNC TWINAX	CONN.BNC X CAVO TWINAX	
12	1	CN3	N CONNECTOR	CONN. N A TELAIO	
13	2	D1, D2	BAT83	HOT CARRIER DIODE	
14	1	CS1	CSDRCPJ1KM	CS DIR.COUPLER PJ1KM	

Pagina lasciata intenzionalmente in bianco
This page was intentionally left blank

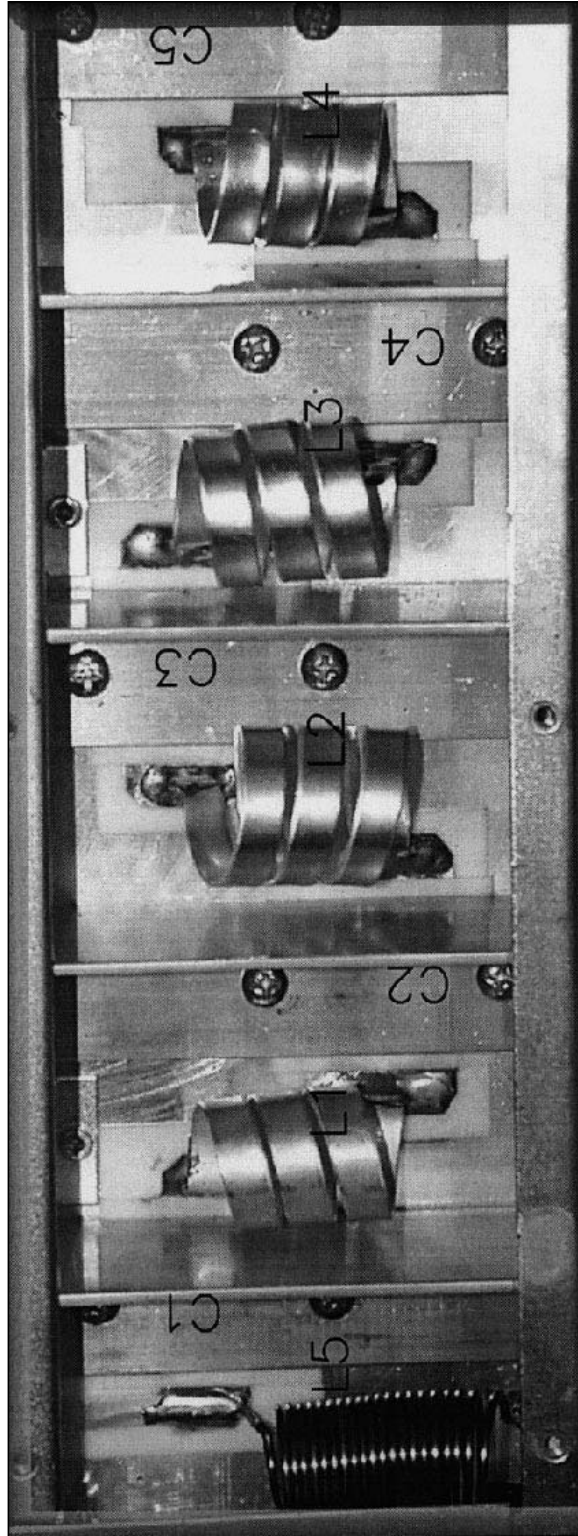

DENOMINAZIONE		Low Pass Filter Photo	
DISPOSITIVI		DISPOSITIVI	
SEMILAVORATO		DISEGNATO	DISEGNO
MATERIALE		Berti J.	11 18/01/01
TRATTAMENTO		SCALA	TAVOLA n
			di

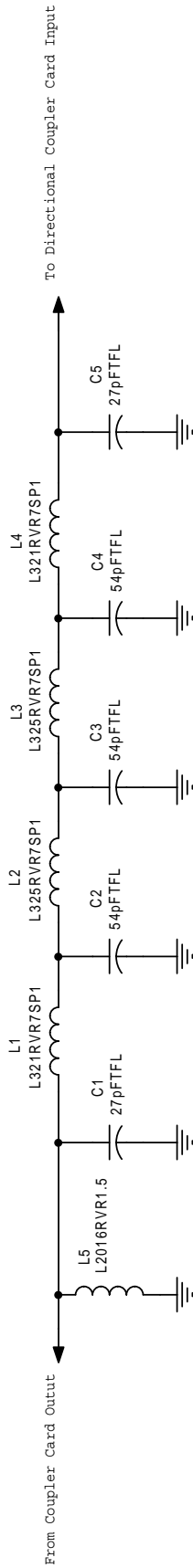

R.V.R. ELETTRONICA S.r.l. (Bo)

Title		Low Pass Filter Circuit Diagram	
Size	Document Number	Rev	00
Date: Thursday, January 11, 2001		Sheet	1 of 1

Low Pass Filter Circuit Diagram

Bill Of Materials

Page 1

Item	Quantity	Reference	Part	DESCRIPTION	PART ORDER CODE
1	2	C1, C5	27PFTFL	CONDBANDELLA RAME TEFLON	
2	3	C2, C3, C4	54PFTFL	COND.BANDELLA RAME TEFLON	
3	2	L1, L4	L321RVR7SP1	RAME ARG.3SP DIA21 7MM SP1	
4	2	L2, L3	L325RVR7SP1	RAME ARG.3SP DIA25 7MM SP1	
5	1	L5	L2016RVR1.5	RAME ARG.1.5MM 20SP DIA16MM	

Pagina lasciata intenzionalmente in bianco
This page was intentionally left blank

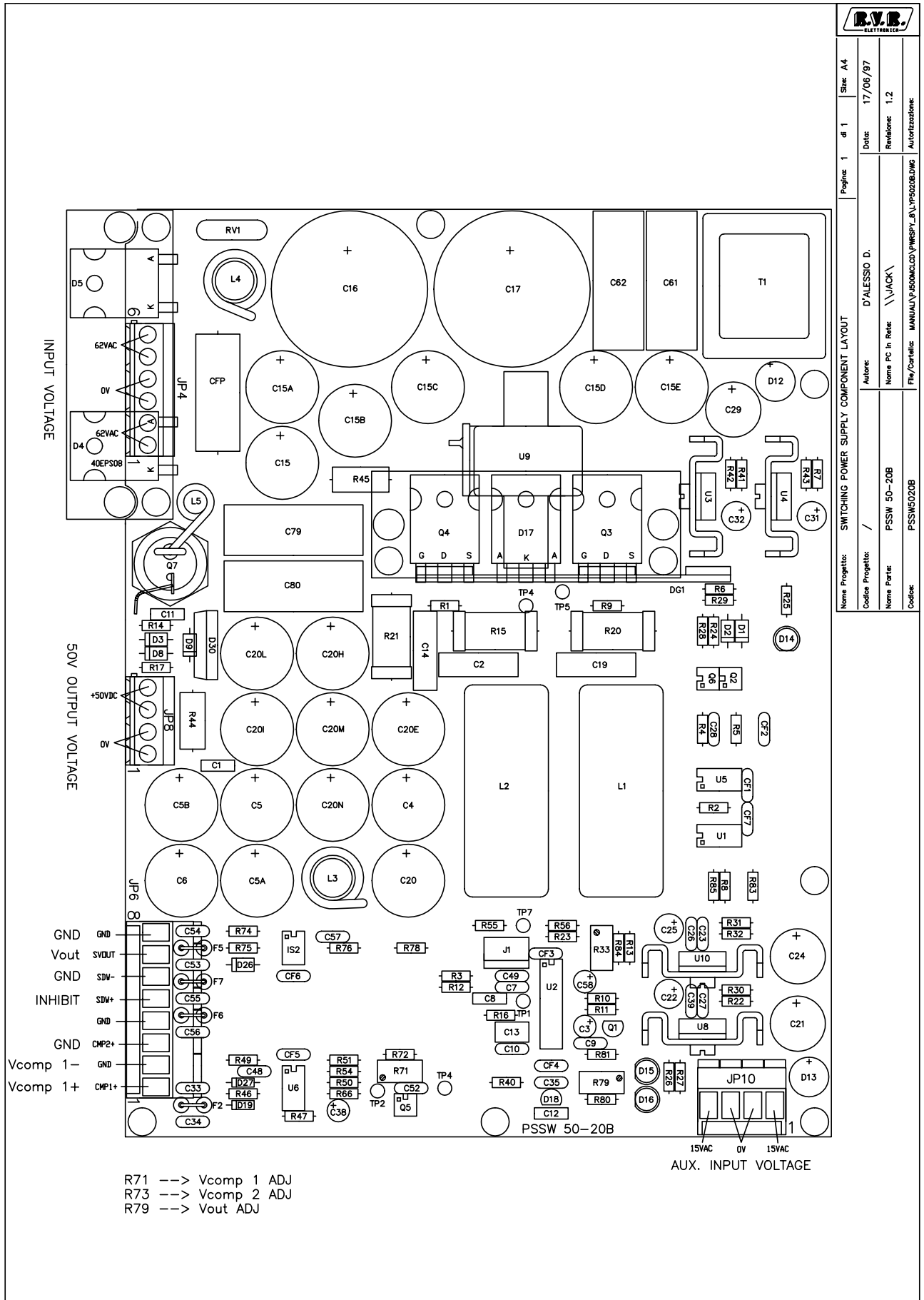

R.V.R. ELETTRONICA	
Nome Progetto: SWITCHING POWER SUPPLY COMPONENT LAYOUT	Autore: D'ALESSIO D.
Nome Parte: PSSW 50-20B	Nome Pk in Rete: \\JACK\
Nome Codice: PSSW5020B	File/Cartella: MANU\U\p-500M\CAD\WMS\PI_A\U\PS5020B.DWG
Pagina: 1	di 1
Stato: A4	Data: 17/06/97
Revisione: 1.2	Autore/Revisione:

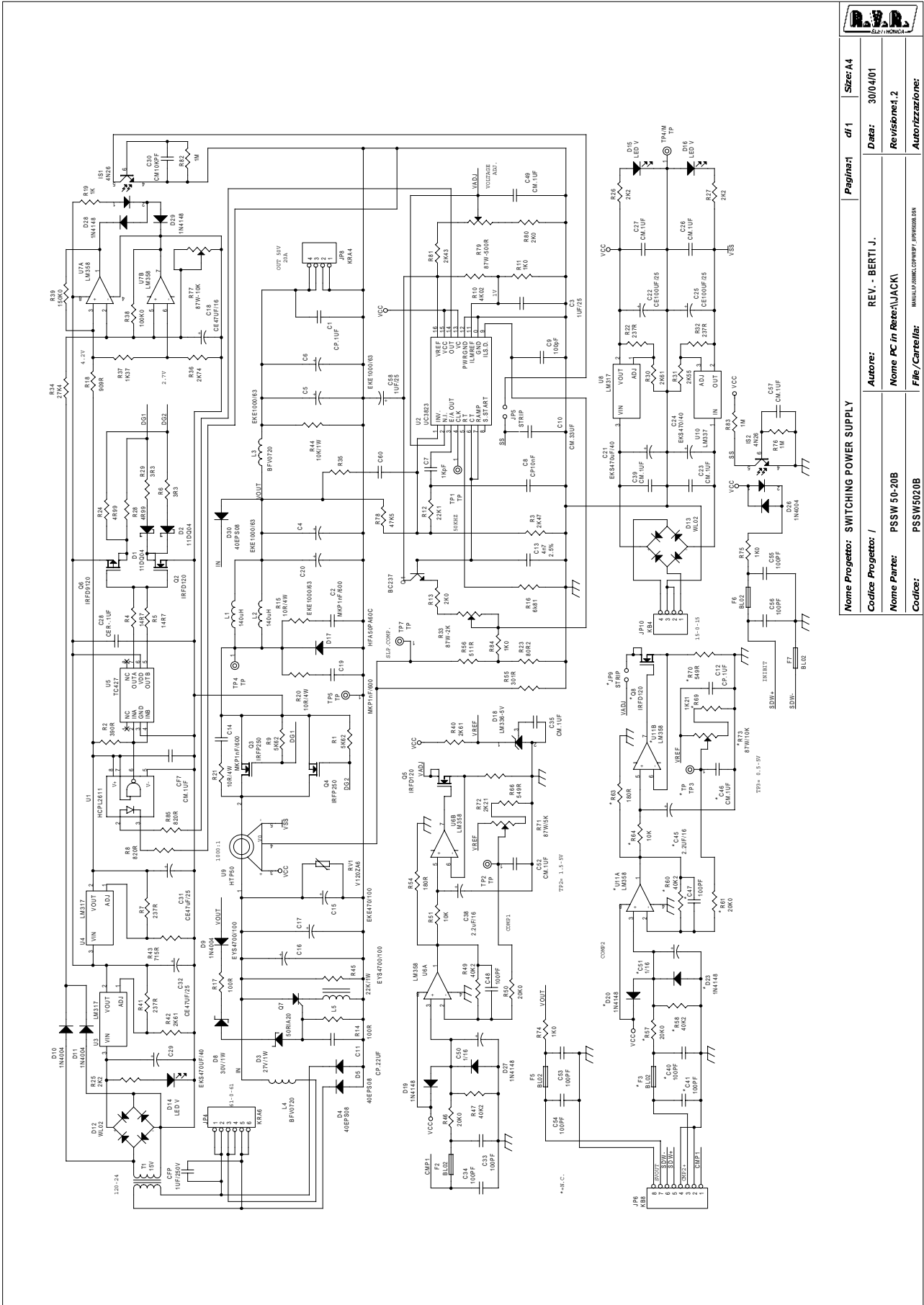

Nome Progetto: SWITCHING POWER SUPPLY	Pagina: df1
Autore: REV. - BERTI J.	Size: A4
Codice Progetto: /	Data: 30/04/01
Nome Parte: PSSW 50-20B	Revisione: 2
Codice: PSSW5020B	File/Carrello: MANUAL/000M.COPY/REV/000000A
Autorizzazione:	

Item	Quantity	Reference	Part
1	1	CFP	1UF/250V
2	9	CF7, C23, C26, C27, C35, C39, C49, C52, C57	CM. 1UF
3	2	C1, C12	CP. 1UF
4	3	C2, C14, C19	MKP1NF/600
5	2	C3, C58	1UF/25
6	4	C4, C5, C6, C20	EKE1000/63
7	1	C7	1KPF
8	1	C8	CP10NF
9	8	C9, C33, C34, C48, C53, C54, C55, C56	100PF
10	1	C10	CM. 33UF
11	1	C11	CP. 22UF
12	1	C13	4N7
13	1	C15	EKE470/100
14	2	C16, C17	EYS4700/100
15	1	C18	CE47UF/16
16	2	C21, C29	EKS470UF/40
17	2	C22, C25	CE100UF/25
18	1	C24	EKS470/40
19	1	C28	CER- .1UF
20	1	C30	CM10KPF
21	2	C31, C32	CE47UF/25
22	1	C38	2.2UF/16
23	1	C50	1/16
24	2	R35, C60	NC
25	2	D1, D2	11DQ04
26	1	D3	27V/1W
27	3	D4, D5, D30	40EPS08

28	1	D8	30V/1W
29	4	D9, D10, D11, D26	1N4004
30	2	D12, D13	WL02
31	3	D14, D15, D16	LED V
32	1	D17	HFA50PA60C
33	1	D18	LM336-5V
34	4	D19, D27, D28, D29	1N4148
35	4	F2, F5, F6, F7	BL02
36	2	IS1, IS2	4N26
37	1	JP4	KRA6
38	1	JP5	STRIP
39	1	JP6	KB8
40	1	JP8	KRA4
41	1	JP10	KB4
42	2	L1, L2	140UH
43	2	L3, L4	BFV0720
44	1	L5	BFV0710
45	1	Q1	BC237
46	2	Q2, Q5	IRFD120
47	2	Q3, Q4	IRFP250
48	1	Q6	IRFD9120
49	1	Q7	50RIA20
50	1	RV1	V120ZA6
51	2	R1, R9	5K62
52	1	R2	390R
53	1	R3	2K47
54	2	R4, R5	14R7
55	2	R6, R29	3R3
56	4	R7, R22, R32, R41	237R
57	2	R8, R85	820R

58	1	R10	4K02
59	4	R11, R74, R75, R84	1K0
60	1	R12	22K1
61	2	R13, R80	2K0
62	2	R14, R17	100R
63	3	R15, R20, R21	10R/4W
64	1	R16	6K81
65	1	R18	909R
66	1	R19	1K
67	1	R23	80R2
68	2	R24, R28	4R99
69	3	R25, R26, R27	2K2
70	3	R30, R40, R42	2K61
71	1	R31	2K55
72	1	R33	87W-2K
73	1	R34	27K4
74	1	R36	2K74
75	1	R37	1K37
76	1	R38	100K0
77	1	R39	150K0
78	1	R43	715R
79	1	R44	10K/1W
80	1	R45	22K/1W
81	4	R46, R50, R57, R61	20K0
82	2	R47, R49	40K2
83	1	R51	10K
84	1	R54	180R
85	1	R55	301R
86	1	R56	511R
87	1	R66	549R

88	1	R71	87W/5K
89	1	R72	2K21
90	3	R76, R82, R83	1M
91	1	R77	87W-10K
92	1	R78	47K5
93	1	R79	87W-500R
94	1	R81	2K43
95	6	TP1, TP2, TP5, TP4/M, TP4, TP7	TP
96	1	T1	15V
97	1	U1	HCPL2611
98	1	U2	UC3823
99	3	U3, U4, U8	LM317
100	1	U5	TC427
101	2	U6, U7	LM358
102	1	U9	HTP50
103	1	U10	LM337
104	20	C41, C40, C51, C47, C46, C45, F3, R60, R64, R63, JP9, Q8, R70, R73, R69, R58, D20, D23, U11, TP3	NC

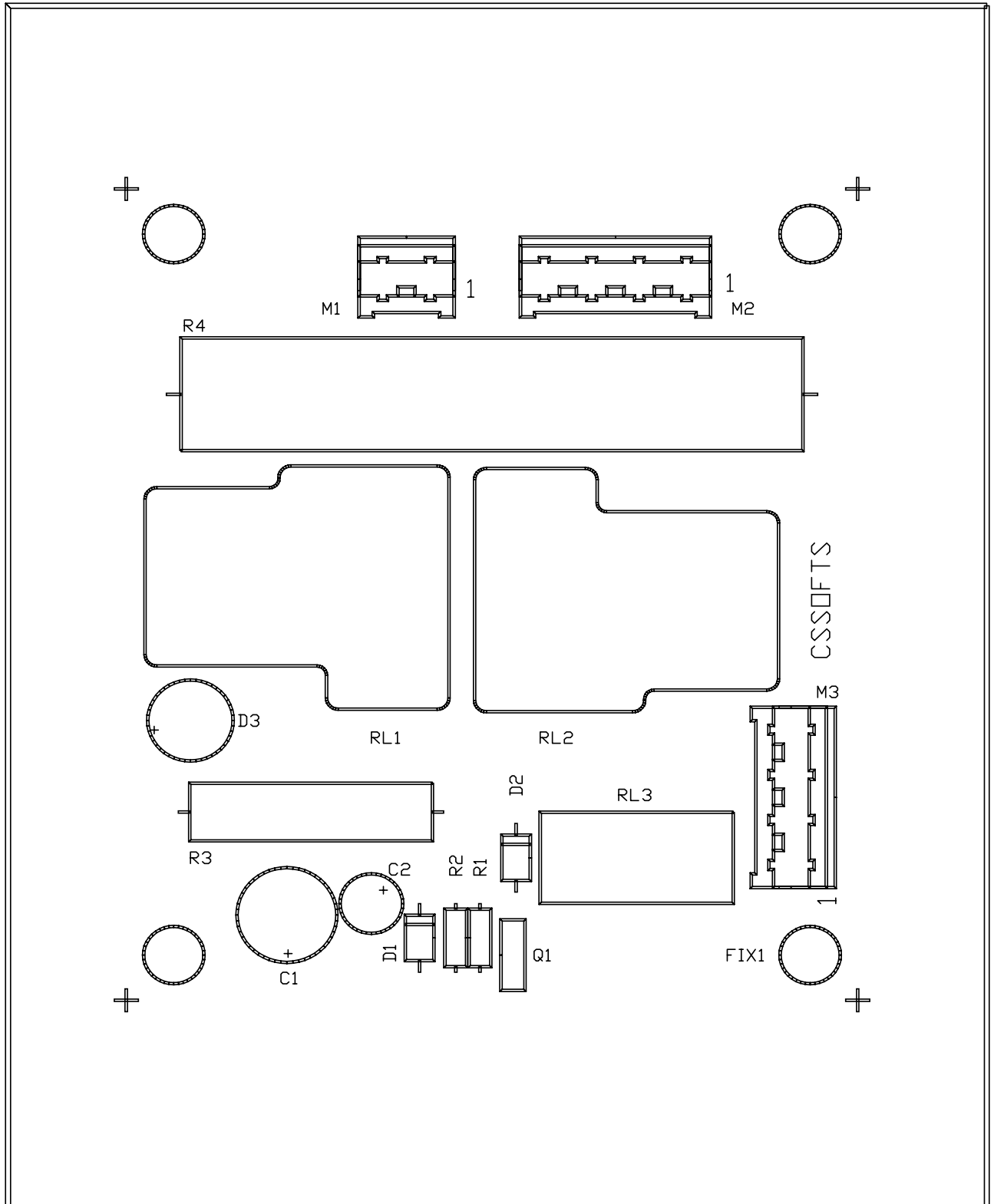

	DENOMINAZIONE soft start	
	DISPOSITIVO	
SEMILAVORATO	DISEGNATO D'Alessio D.li 4/12/00	DISEGNO
MATERIALE	SCALA	TAVOLA n 1 di 1
TRATTAMENTO	1:1	

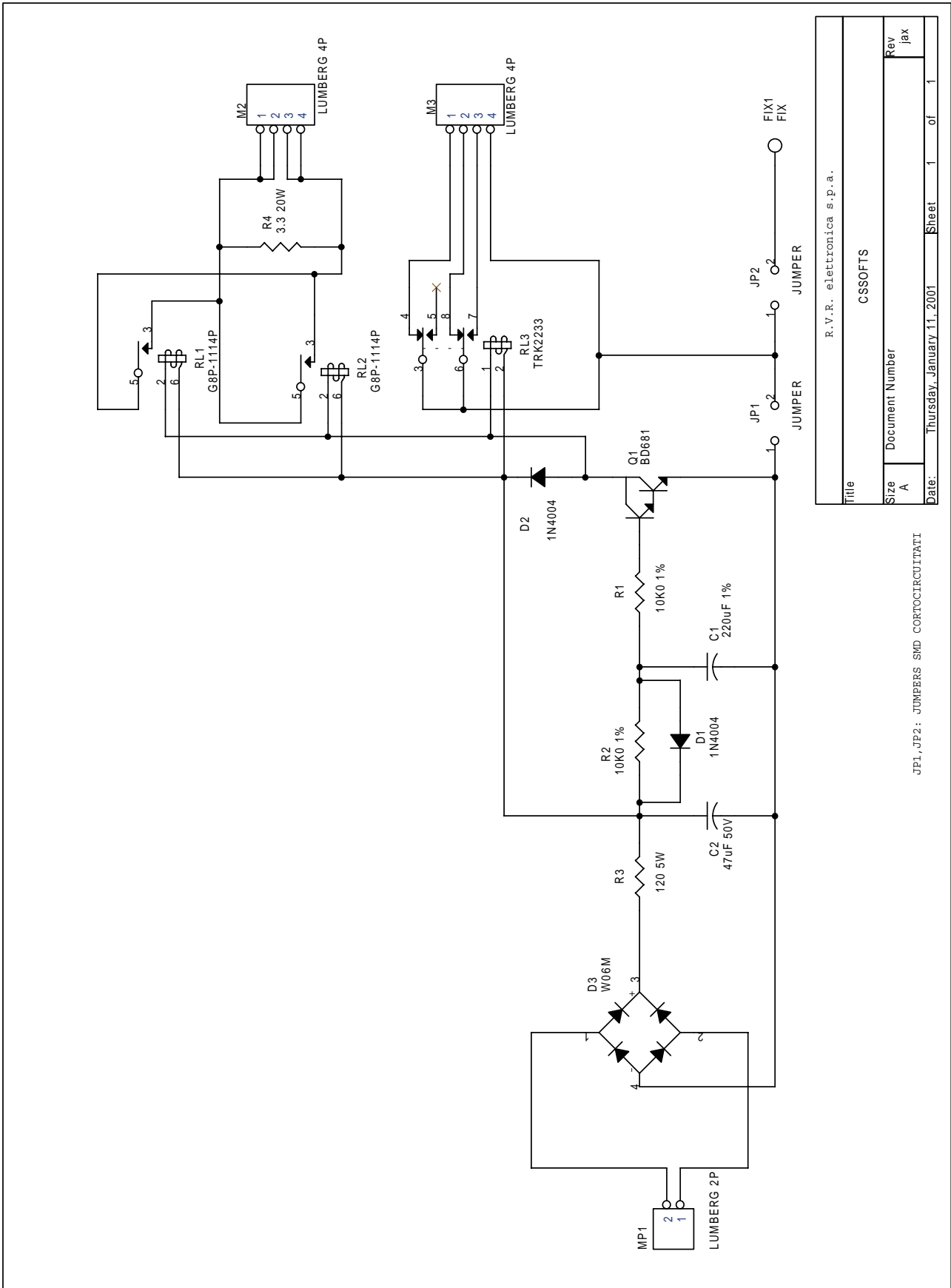

Title		R.V.R. elettronica s.p.a.	
Size	Document Number	CSSOFTS	
A		Rev	jax
Date:	Thursday, January 11, 2001	Sheet	1 of 1

JP1, JP2: JUMPERS SMD CORTOCIRCUITATI

Item	Quantity	Reference	Part	
1	1	C1	220UF 50V	COND. ELETTR.
2	1	C2	47UF 50V	COND. ELETTR.
3	2	D1,D2	1N4004	DIODO AL SILICIO
4	1	D3	W02M	PONTE DI DIODI
5	1	FIX1	FIX	
6	2	JP1,JP2	JUMPER 2P	
7	1	M1	LUMBERG 2P	MORS. 2 PIN
8	2	M2,M3	LUMBERG 4P	MORS. 4 PIN
9	1	Q1	BD681	TRANSISTOR
10	2	RL1,RL2	G8P-1114P	RELè G8-1114P
11	1	RL3	V23042 A 2003	RELè 2SC. 2VIE
12	2	R1,R2	10K	RES. STRATO MET.
13	1	R3	120 5W	RES. A FILO
14	1	R4	4.7 20W	RES. A FILO

Pagina lasciata intenzionalmente in bianco
This page was intentionally left blank

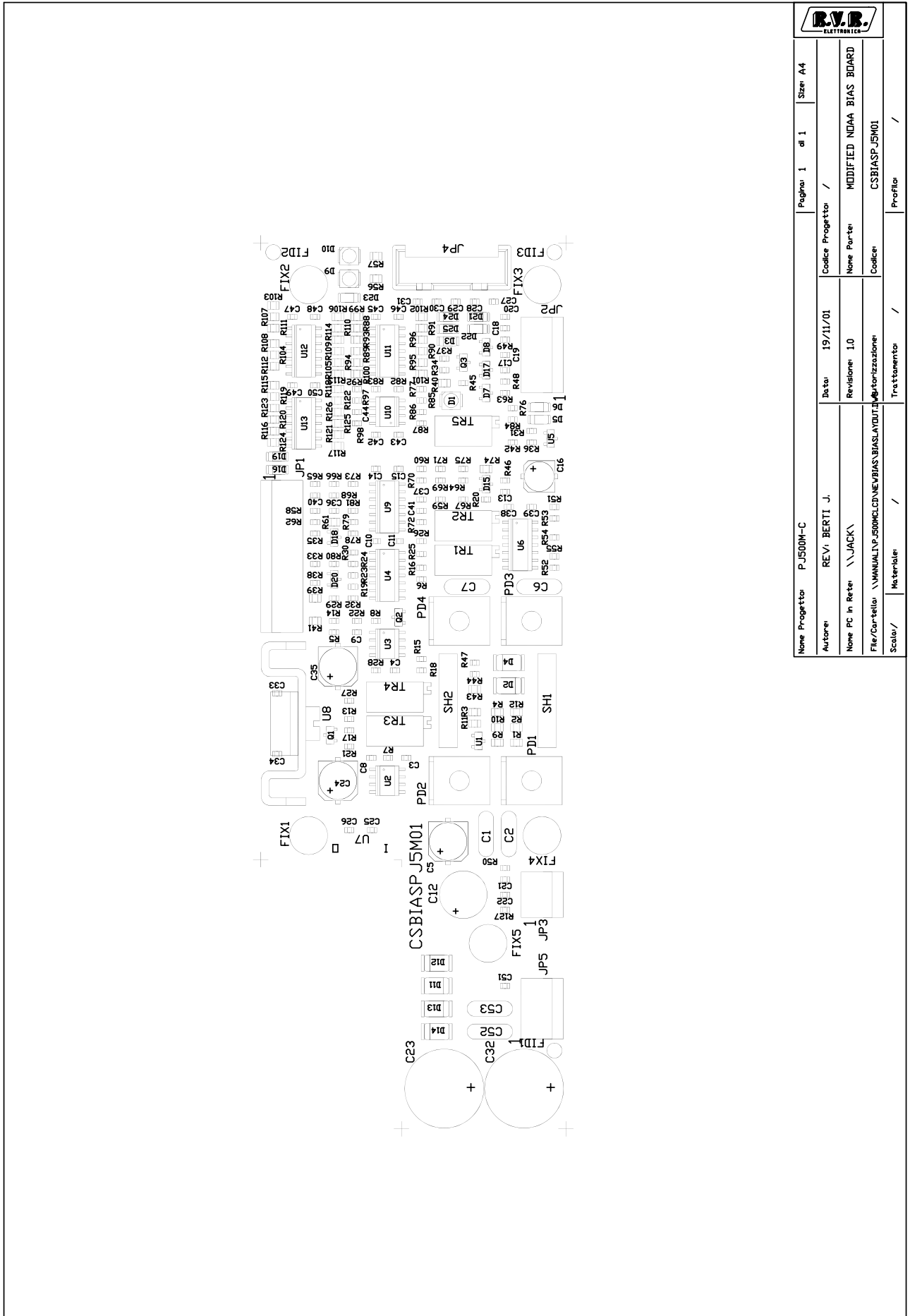

		Pagina: 1	di 1	Size: A4
Nome Progetto:	PJ500M-C	Data:	19/11/01	Codice Progettista: /
Autore:	REV. BERTI J.	Revisioni:	1.0	Nome Parte: MODIFIED NDA4 BIAS BOARD
Nome PC in Rete:	\\JACKY	File/Cor-tellor:	\\MANUAL\PJ500M\C\NEWBIAS\BIAS\LAY\OUT\JP5\forizzazione	Codice: CSBIASPJ5M01
Scala: /	Materiale: /	Traffimento:	/	Profilo: /

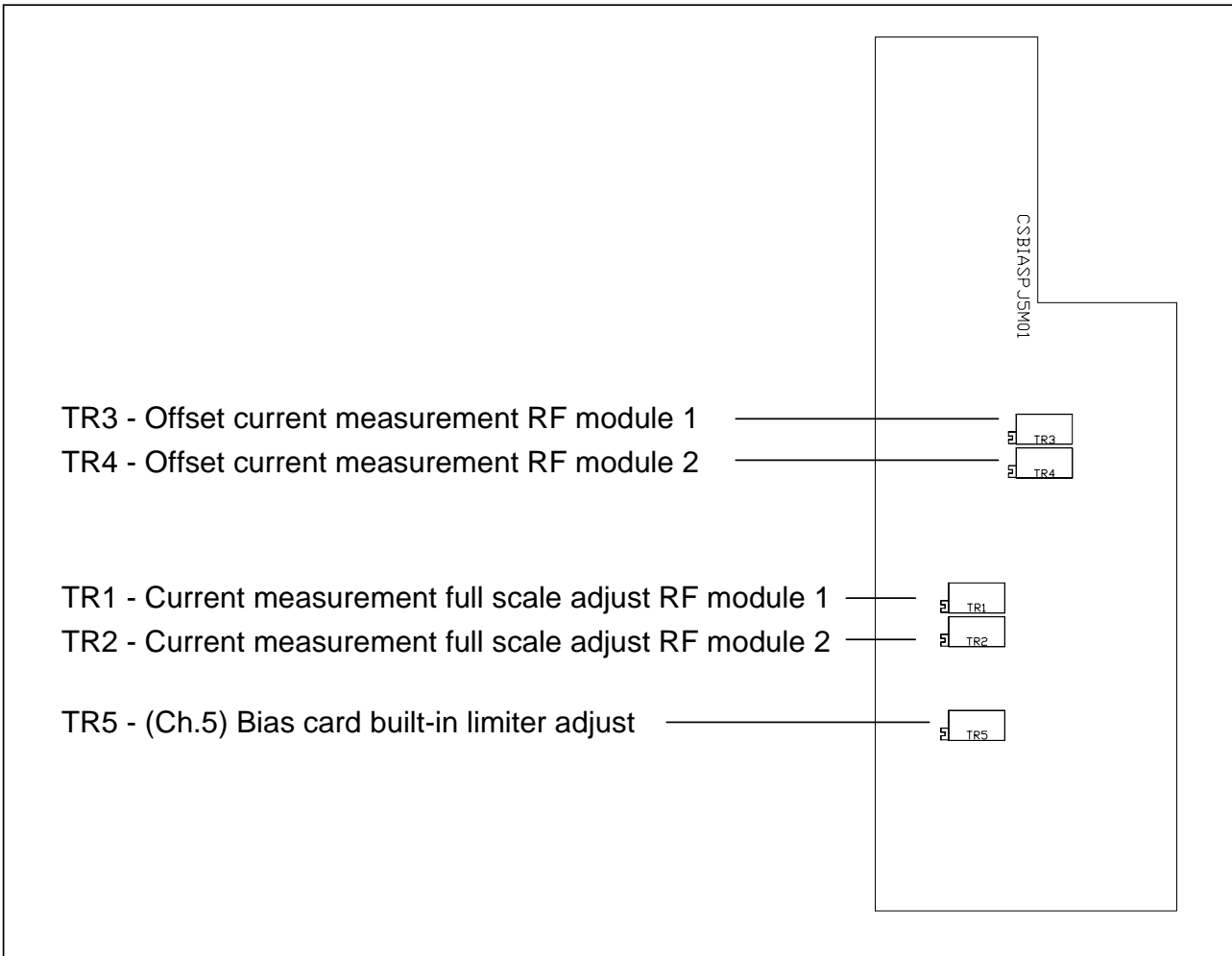

Notes:

- TR1, TR2, TR3, and TR4 are not supposed to be user-adjustable components. They should only be adjusted by skilled personnel for maintenance.
- TR3 and TR4 are used to adjust the offset of the measurement of the current, that is the value measured when $I=0$. Adjust the trimmers so that the voltages on test points I1 and I2 on JP1 are 0V.
- TR1 and TR2 are used to adjust the full scale of the measurement of the current, that is the value measured when $I=10.5A$. Adjust the trimmers so that the voltages on test points I1 and I2 on JP1 are 4.0V.
- TR5 adjusts the power limiting built-in in the bias card. It is factory adjusted at 560W. To change it, turn the "PWR ADJ." trimmer on the completely clockwise (so that the AGC doesn't affect the system). Use adjust the exciter's power at 10W. Adjust TR5 to obtain the desired limiting value. Turning the trimmer counterclockwise rises the limiting value. Note that this trimmer's adjusting influences the value displayed by the CPU. This adjustment shall be performed using an external wattmeter, and after this operation the trimmer for the adjustment of the measurement in the CPU shall be readjusted.

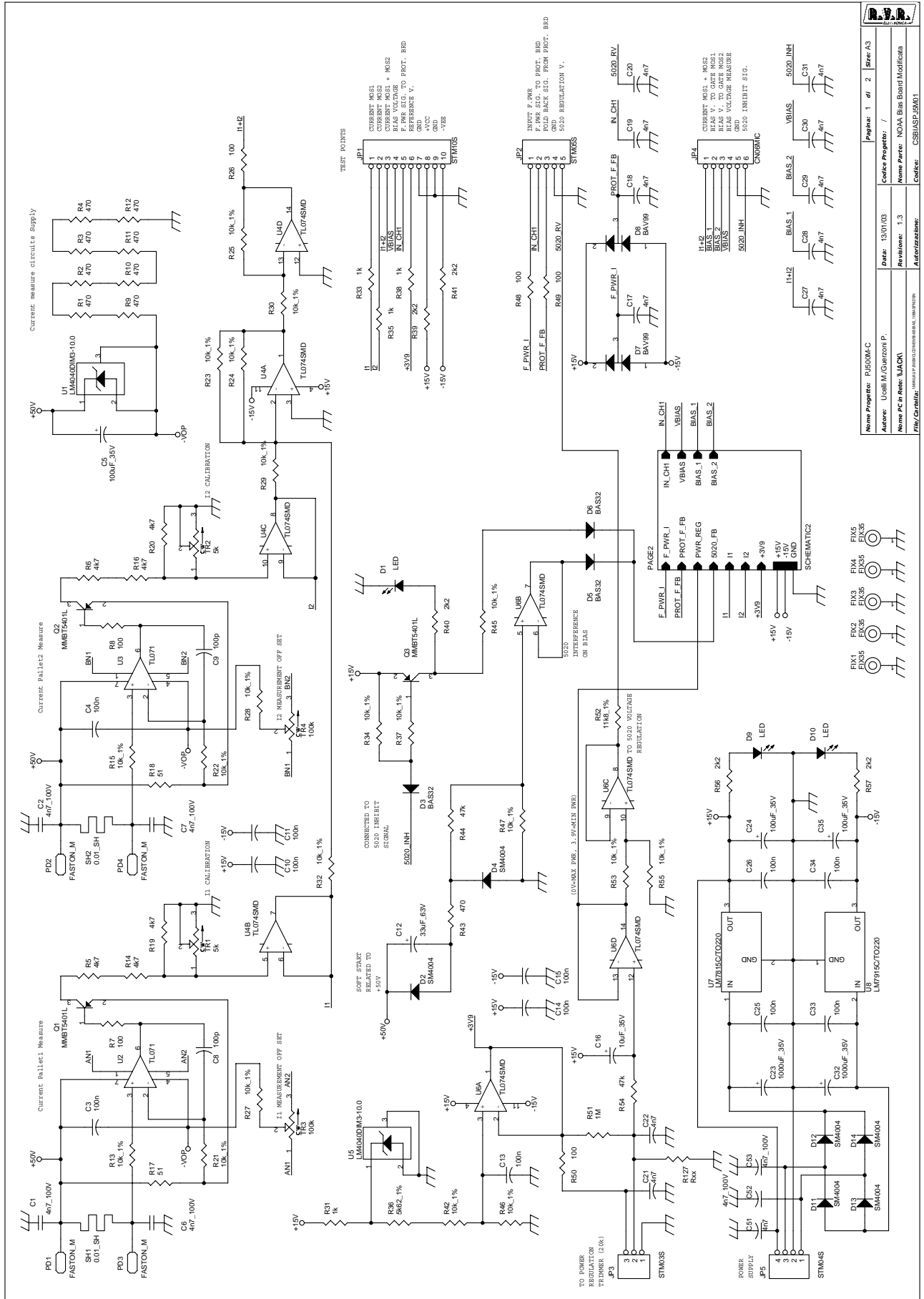

Nome Progetto: PJ500M-C	Revisione: 1.3	Autore: Ucelli M/Quaranta P.	Nome PC in Rete: LACKA
Nome File: PJ500M-C	Revisione: 1.3	Autore: Ucelli M/Quaranta P.	Nome PC in Rete: LACKA
Nome File: PJ500M-C	Revisione: 1.3	Autore: Ucelli M/Quaranta P.	Nome PC in Rete: LACKA
Nome File: PJ500M-C	Revisione: 1.3	Autore: Ucelli M/Quaranta P.	Nome PC in Rete: LACKA

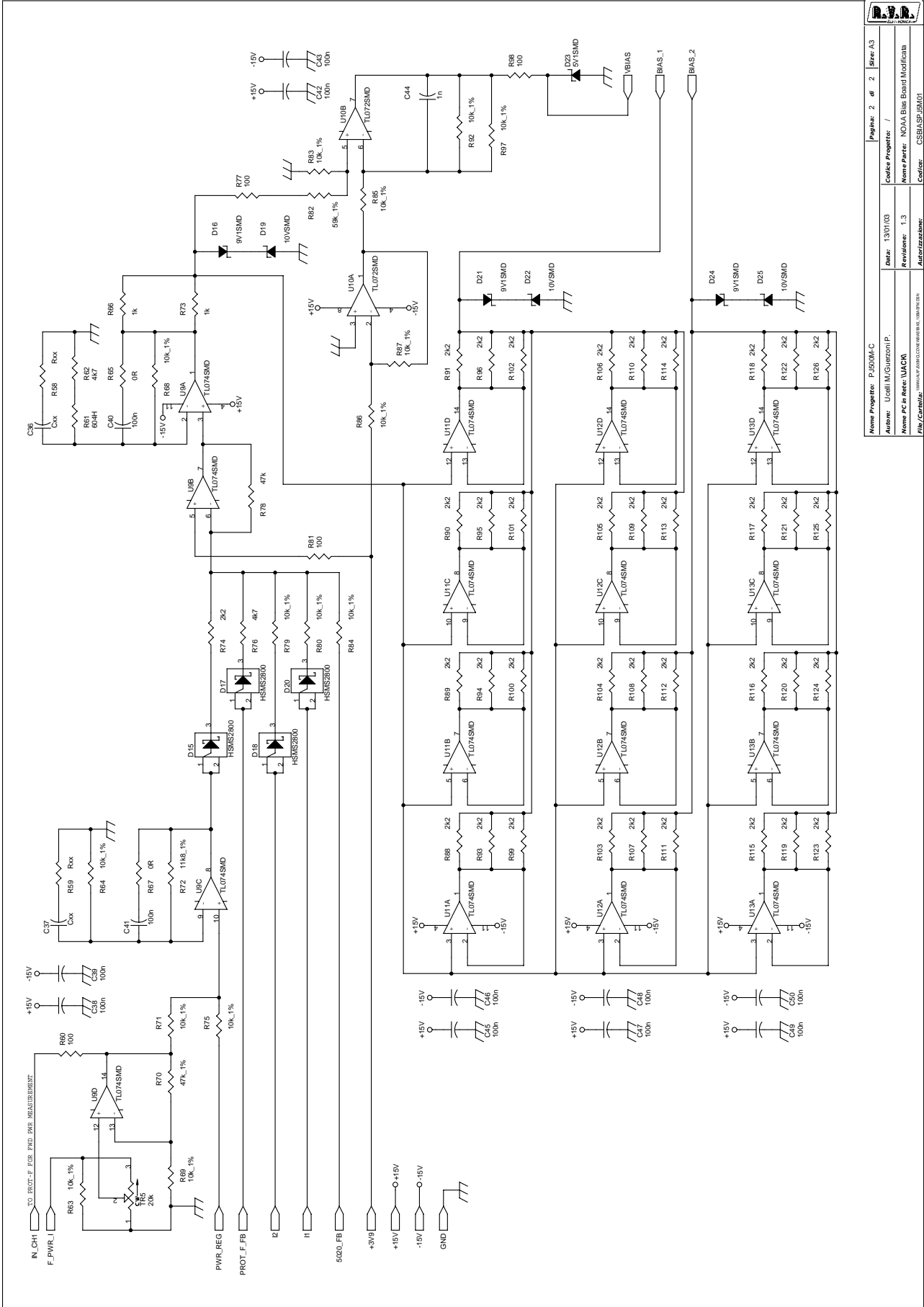

R.V.R. ELETTRONICA	
Nome Progetto: PJ500M-C	Figura: 2 di 2
Autore: Ucelli M/Guizzoni P.	Rev: 1.3
Nome File: NOAA Bias Board Modificata	Autore: CSBIASPJ5M01
File/Caratteristiche: UMLIB\PROJ\BOARD\BIAS\UMLIB\BIAS	

CSBIASPJ5M01 Bill Of Materials Page1

Item	Q.ty	Reference	Part
1	6	C1, C2, C6, C7, C52, C53	4n7_100V
2	23	C3, C4, C10, C11, C13, C14, C15, C25, C26, C33, C34, C38, C39, C40, C41, C42, C43, C45, C46, C47, C48, C49, C50	100n
3	3	C5, C24, C35	100uF_35V
4	2	C8, C9	100p
5	1	C12	33uF_63V
6	1	C16	10uF_35V
7	12	C17, C18, C19, C20, C21, C22, C27, C28, C29, C30, C31, C51	4n7
8	2	C23, C32	1000uF_35V
9	2	C37, C36	Cxx
10	1	C44	1n
11	3	D1, D9, D10	LED
12	6	D2, D4, D11, D12, D13, D14	SM4004
13	3	D3, D5, D6	BAS32
14	2	D7, D8	BAV99
15	4	D15, D17, D18, D20	HSMS2800
16	3	D16, D21, D24	9V1SMD
17	3	D19, D22, D25	10VSMD
18	1	D23	5V1SMD
19	5	FIX1, FIX2, FIX3, FIX4, FIX5	FIX35
20	1	JP1	STM10S
21	1	JP2	STM05S
22	1	JP3	STM03S
23	1	JP4	CN06MIC
24	1	JP5	STM04S
25	4	PD1, PD2, PD3, PD4	FASTON_M
26	3	Q1, Q2, Q3	MMBT5401L
27	9	R1, R2, R3, R4, R9, R10, R11, R12, R43	470
28	8	R5, R6, R14, R16, R19, R20, R62, R76	4k7
29	10	R7, R8, R26, R48, R49, R50, R60, R77, R81, R98	100
30	35	R13, R15, R21, R22, R23, R24, R25, R27, R28, R29, R30, R32, R34, R37, R42, R45, R46, R47, R53, R55, R63, R64, R68, R69, R71, R75, R79, R80, R83, R84, R85, R86, R87, R92, R97	10k_1%
31	2	R17, R18	51
32	6	R31, R33, R35, R38, R66, R73	1k
33	1	R36	5k62_1%
34	42	R39, R40, R41, R56, R57, R74, R88, R89, R90, R91, R93, R94, R95, R96, R99, R100, R101, R102, R103, R104, R105, R106, R107, R108, R109, R110, R111, R112, R113, R114, R115, R116, R117, R118, R119, R120, R121, R122, R123, R124, R125, R126	2k2
35	3	R44, R54, R78	47k
36	1	R51	1M

37	2	R52, R72	11k8_1%
38	3	R58, R59, R127	Rxx
39	1	R61	604H
40	2	R67, R65	0R
41	1	R70	47k_1%
42	1	R82	59k_1%
43	2	SH1, SH2	0.01_SH
44	2	TR1, TR2	5k
45	2	TR3, TR4	100k
46	1	TR5	20k
47	2	U1, U5	LM4040DIM3-10.0
48	2	U2, U3	TL071
49	6	U4, U6, U9, U11, U12, U13	TL074SMD
50	1	U7	LM7815C/TO220
51	1	U8	LM7915C/TO220
52	1	U10	TL072SMD

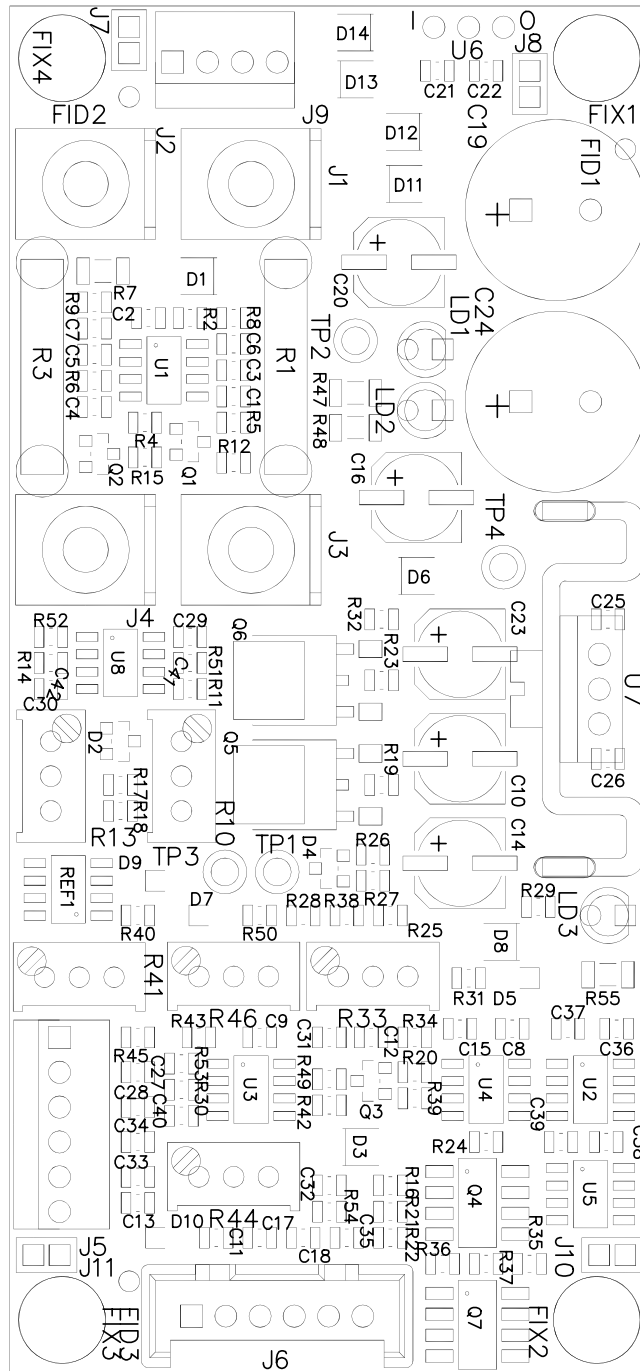

DENOMINAZIONE SCHEDA CONTROL BIAS M-C VERS.LCD
 DISPOSITIVO CSBIASPJ5MCL01

SEMILAVORATO	DISEGNATO	DISEGNO
MATERIALE	li	
TRATTAMENTO	SCALA	TAVOLA n di

Versione precedente, solo per riferimento

Former version, for reference only

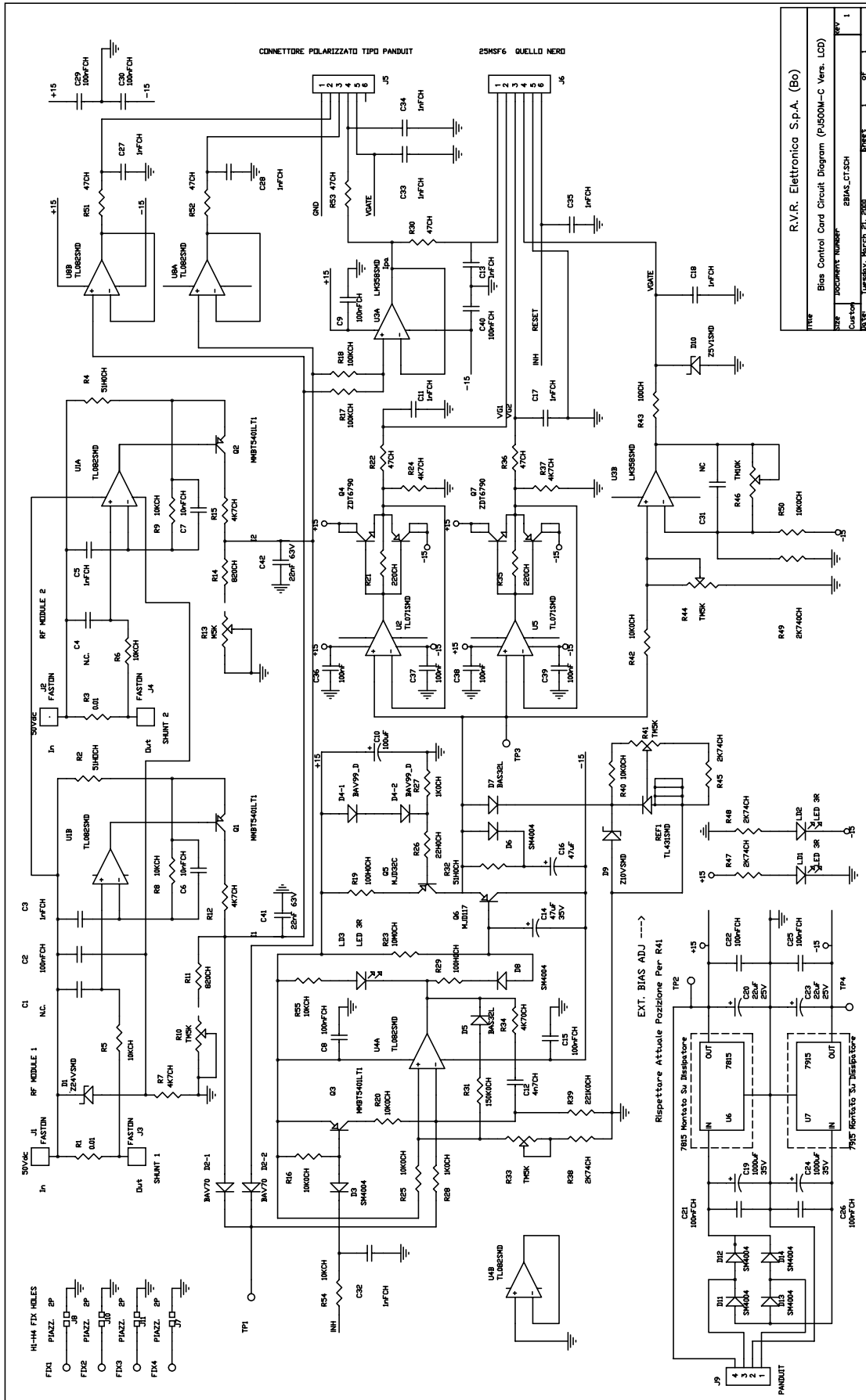

Versione precedente, solo per riferimento
Former version, for reference only

Bias Control Card Bill Of Materials

R.V.R. Elettronica s.p.a. (BO)

Item	Q.ty	Reference	Part
1	12	C3,C34,C35,	1nFCH
		C5,C11,C13,	
		C17,C18,C27,	
		C28,C32,C33	
2	11	C2,C8,C9,	100nFCH
		C15,C21,C22,	
		C25,C26,C29,	
		C30,C40	
3	2	C6,C7	10nFCH
4	1	C10	100uF
5	1	C12	4n7CH
6	2	C16,C14	47uF
7	2	C19,C24	1000uF
8	2	C20,C23	22uF
9	1	C31	NC
10	4	C36,C37,C38,	100nF
		C39	
11	1	D1	Z24VSMD
12	1	D2	BAV70
13	7	D3,D6,D8,D11,	SM4004
		D12,D13,D14	
14	1	D4	BAV99_D
15	2	D7,D5	BAS32L
16	1	D9	Z10VSMD
17	1	D10	Z5V1SMD
18	4	FIX1, FIX2, FIX3, FIX4	
19	4	J1, J2, J3, J4	FASTON
20	1	J5	PANDUIT
21	1	J6	25MSF6
22	1	J9	PANDUIT
23	3	LD1, LD2, LD3	LED 3R
24	3	Q1, Q2, Q3	MMBT5401LT1
25	2	Q4, Q7	ZDT6790
26	1	Q5	MJD32C
27	1	Q6	MJD117
28	1	REF1	TL431SMD
29	2	R1, R3	0.01
30	1	R2	51HOCH
31	2	R32, R4	51H0CH
32	6	R5, R6, R8, R9,	10KCH
		R54, R55	
33	5	R7, R15, R24,	4K7CH
		R37, R12	
34	4	R10, R33, R41, R44	TM5K
35	2	R27, R28	1K0CH
36			
37	1	R13	M5K
38	2	R11, R14	820CH
39	6	R16, R20, R25,	10K0CH
		R40, R42, R50	
40	2	R18, R17	100KCH
41	2	R19, R29	100H0CH
42	2	R35, R21	220CH

43	6	R22 ,R30 ,R36 ,47CH R51 ,R52 ,R53	
44	1	R23	10M0CH
45	1	R26	22H0CH
46	1	R31	150K0CH
47	1	R34	4K70CH
48	4	R38 ,R45 ,R47 ,2K74CH R48	
49	1	R39	221K0CH
50	1	R43	100CH
51	1	R46	TM10K
52	1	R49	2K740CH
53	4	TP1 ,TP2 ,TP3 ,TestPoint TP4	
54	3	U1 ,U4 ,U8	TL082SMD
55	2	U2 ,U5	TL071SMD
56	1	U3	LM358SMD
57	1	U6	7815
58	1	U7	7915
59	2	C1 ,C4	N.C.

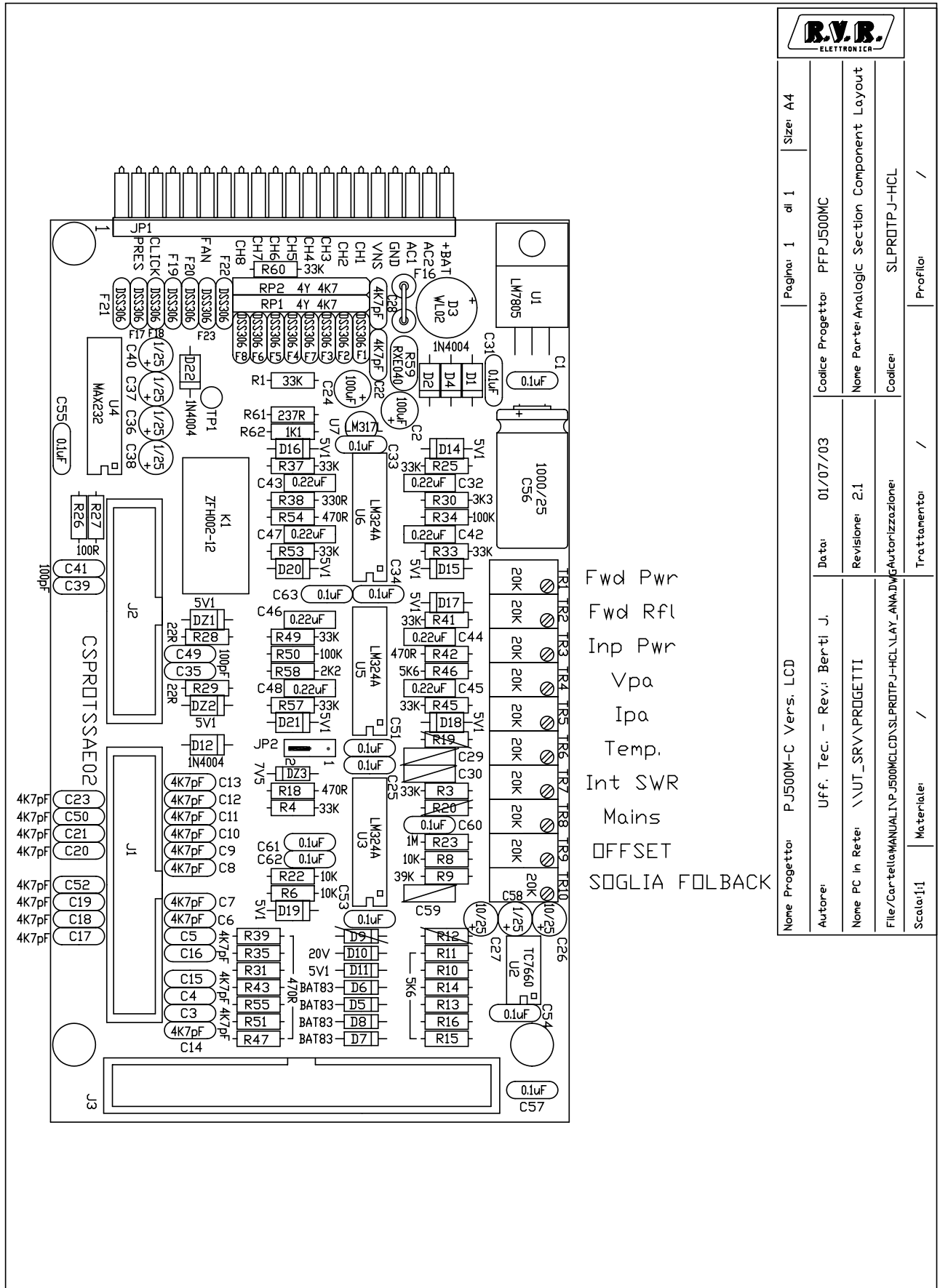

R.V.R. ELETTRONICA	
Nome Progetto: PJ500M-C Vers. LCD	Size: A4
Autore: Uff. Tec. - Rev: Berti J.	Pagina: 1 di 1
None PC in Rete: \\UT_SRV\PROGETTI	Coalce Progetto: PFPJ500MC
File/Cartella\MANUALI\PJ500M\CAD\SLPROTPJ-HCL\LAY_ANA.DWG\Autorizzazione:	None Parte: Analogic Section Component Layout
Scale: 1:1	Coalce: SLPROTPJ-HCL
Materiali: /	Profilo: /
Trattamento: /	
Data: 01/07/03	
Revisione: 2.1	

Fwd Pwr
 Fwd Rfl
 Inp Pwr
 Vpa
 Ipa
 Temp.
 Int SWR
 Mains
 OFFSET
 SOGLIA FOLBACK

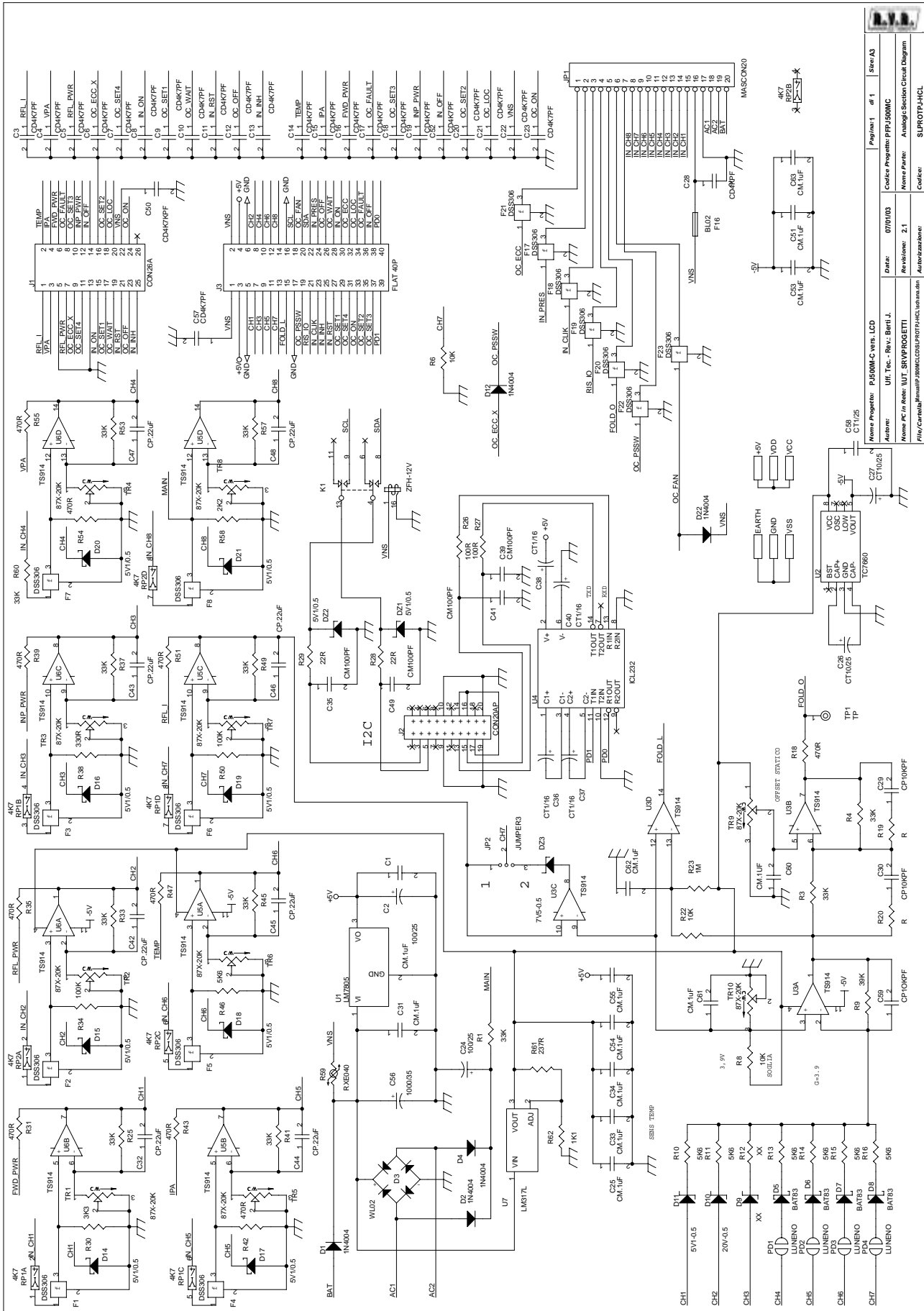

Nome Progetto:	PJ500M-C w/ta_LCD	Revisione:	07/01/03	Autore:	Uff. Tec. - Riv. J. Berit J.	Progetto:	07/01/03	Autore:	Uff. Tec. - Riv. J. Berit J.
Nome File:	Uff. Proj. PJPJ500M-C	Revisione:	2.1	Autore:	Uff. Tec. - Riv. J. Berit J.	Progetto:	07/01/03	Autore:	Uff. Tec. - Riv. J. Berit J.
File/Caricamento:	Uff. Proj. PJPJ500M-C w/ta_LCD	Revisione:	2.1	Autore:	Uff. Tec. - Riv. J. Berit J.	Progetto:	07/01/03	Autore:	Uff. Tec. - Riv. J. Berit J.

Nome Progetto:	PJ500M-C w/ta_LCD	Revisione:	07/01/03	Autore:	Uff. Tec. - Riv. J. Berit J.	Progetto:	07/01/03	Autore:	Uff. Tec. - Riv. J. Berit J.
Nome File:	Uff. Proj. PJPJ500M-C	Revisione:	2.1	Autore:	Uff. Tec. - Riv. J. Berit J.	Progetto:	07/01/03	Autore:	Uff. Tec. - Riv. J. Berit J.
File/Caricamento:	Uff. Proj. PJPJ500M-C w/ta_LCD	Revisione:	2.1	Autore:	Uff. Tec. - Riv. J. Berit J.	Progetto:	07/01/03	Autore:	Uff. Tec. - Riv. J. Berit J.

CPU Analog Section

SLPROTPJ-HCL

Version: 2.1 Date: 01/06/03

Item	Q.ty	Reference	Part
1	13	C1,C25,C31,C33,C34,C51, C53,C54,C55,C60,C61,C62, C63	CM.1uF
2	2	C24,C2	100/25
3	23	C3,C4,C5,C6,C7,C8,C9,C10, C11,C12,C13,C14,C15,C16, C17,C18,C19,C20,C21,C22, C23,C52,C57	CD4K7PF
4	2	C26,C27	CT10/25
5	1	C28	CD4KPF
6	2	C29,C30	CP10KPF
7	8	C32,C42,C43,C44,C45,C46, C47,C48	CP.22uF
8	4	C35,C39,C41,C49	CM100PF
9	4	C36,C37,C38,C40	CT1/16
10	1	C50	CD4K7KPF
11	1	C56	1000/35
12	1	C58	CT1/25
13	1	C59	CP10KPF
14	10	DZ1,DZ2,D14,D15,D16,D17, D18,D19,D20,D21	5V1/0.5
15	1	DZ3	7V5-0.5
16	5	D1,D2,D4,D12,D22	1N4004
17	1	D3	WL02
18	4	D5,D6,D7,D8	BAT83
19	2	R12,D9	XX
20	1	D10	20V-0.5
21	1	D11	5V1-0.5
22	15	F1,F2,F3,F4,F5,F6,F7,F8, F17,F18,F19,F20,F21,F22, F23	DSS306
23	1	F16	BL02
24	1	JP1	MASCON20
25	1	JP2	JUMPER3
26	1	J1	CON26A
27	1	J2	CON20AP
28	1	J3	FLAT 40P
29	1	K1	ZFH-12V
30	4	PD1,PD2,PD3,PD4	LUNENO
31	2	RP1,RP2	4K7
32	12	R1,R3,R4,R25,R33,R37,R41, R45,R49,R53,R57,R60	33K
33	3	R6,R8,R22	10K
34	1	R9	39K
35	7	R10,R11,R13,R14,R15,R16, R46	5K6
36	10	R18,R31,R35,R39,R42,R43, R47,R51,R54,R55	470R
37	2	R19,R20	R
38	1	R23	1M
39	2	R26,R27	100R

40	2	R28,R29	22R
41	1	R30	3K3
42	2	R50,R34	100K
43	1	R38	330R
44	1	R58	2K2
45	1	R59	RXE040
46	1	R61	237R
47	1	R62	1K1
48	1	TP1	TP
49	10	TR1,TR2,TR3,TR4,TR5,TR6, TR7,TR8,TR9,TR10	87X-20K
50	1	U1	LM7805
51	1	U2	TC7660
52	3	U3,U5,U6	TS914
53	1	U4	ICL232
54	1	U7	LM317L

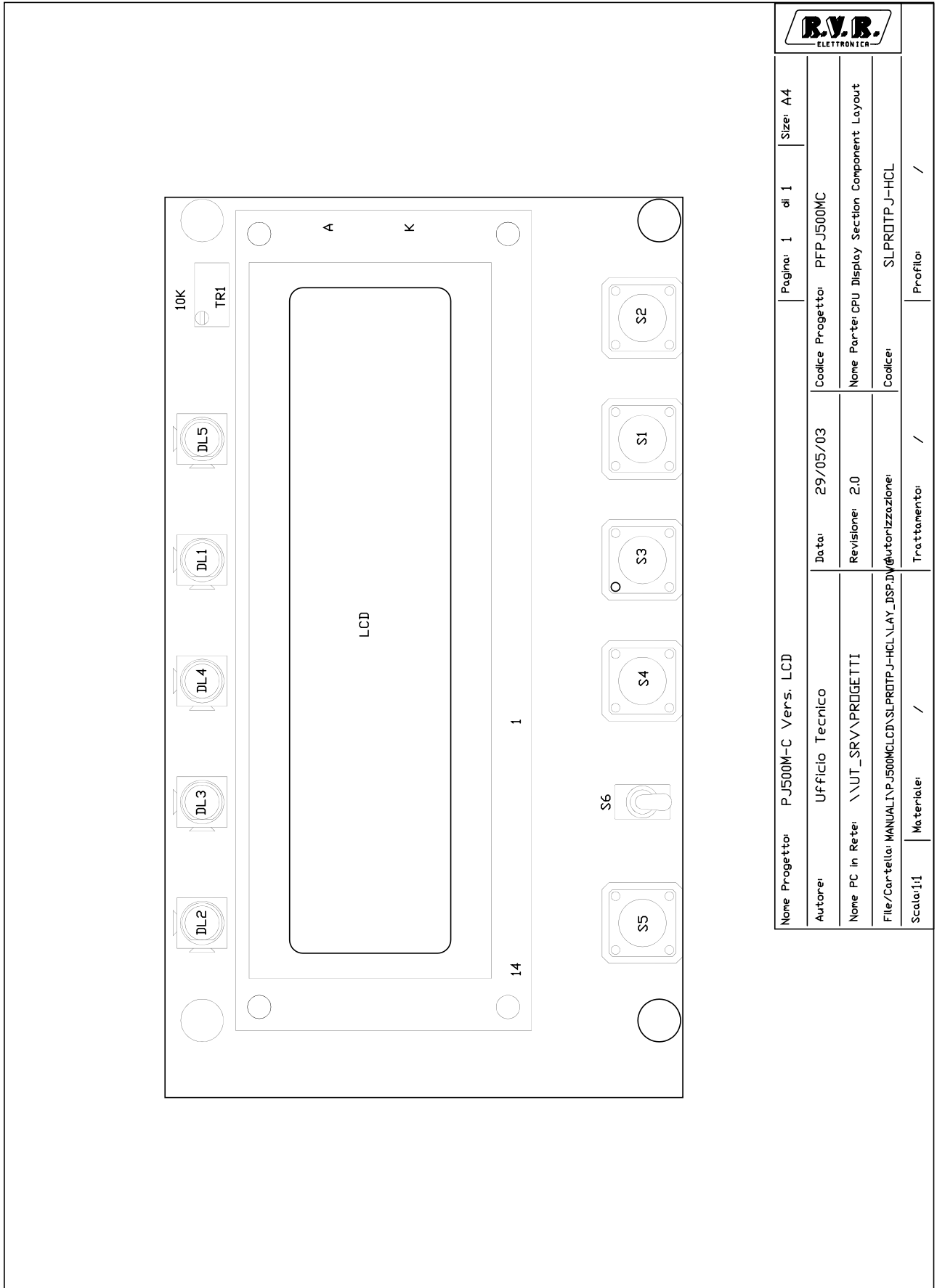

		Nome Progetto: PJ500M-C Vers: LCD		Pagina: 1 di 1		Size: A4	
Autore: Ufficio Tecnico		Data: 29/05/03		Codice Progetto: PFPJ500MC			
Nome PC in Rete: \\UT_SRV\PROGETTI		Revisione: 2.0		Nome Part: CPU Display Section Component Layout			
File/Cartella: MANUAL\PJ500M\CAD\SLPROTPJ-HCL\LAY_DSP.DWG		@autorizzazione:		Codice:		SLPROTPJ-HCL	
Scala: 1:1		Materiale: /		Trattamento: /		Profilo: /	

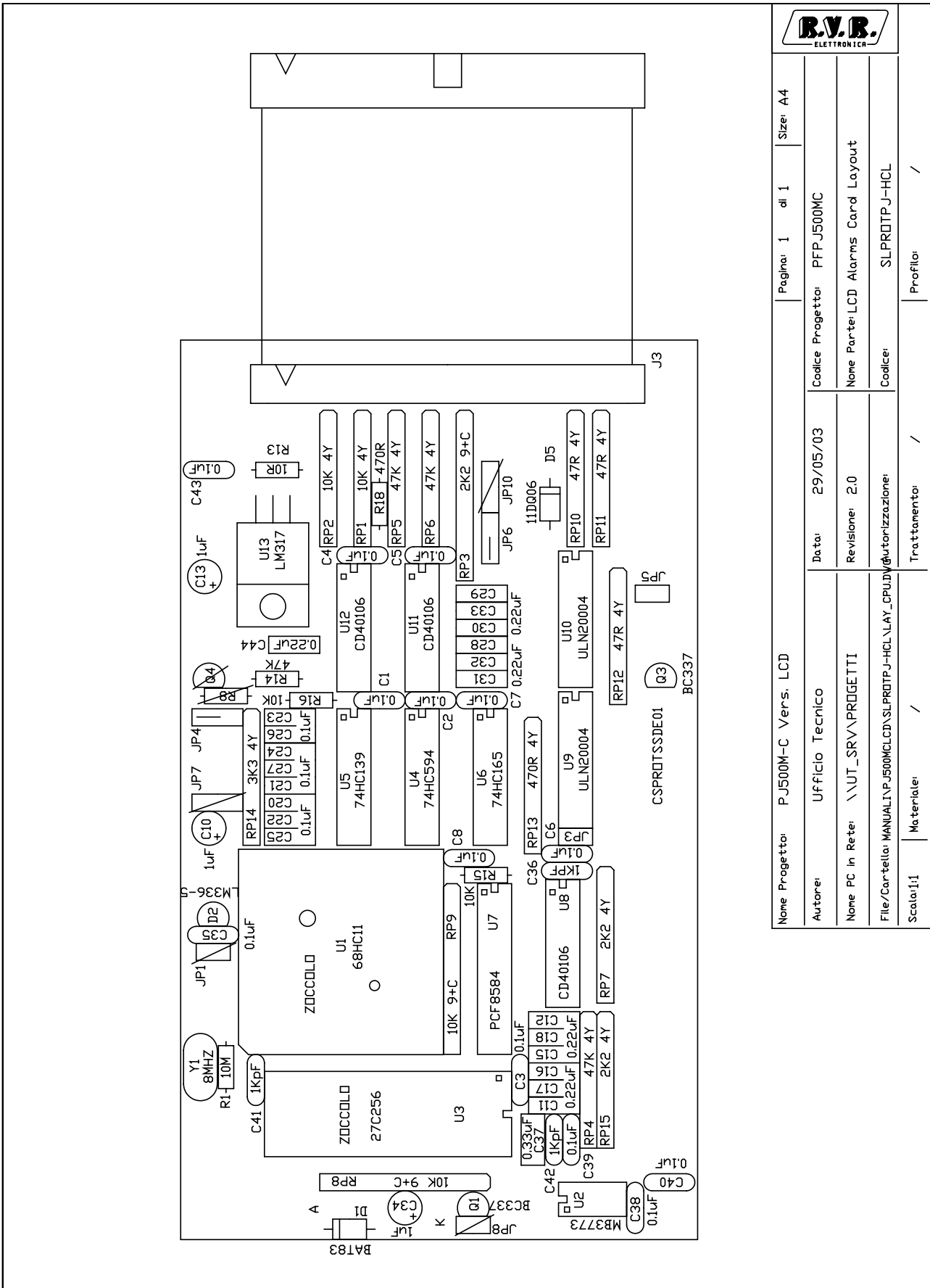

		Pagina: 1	di 1	Size: A4
Nome Progetto: PJ500M-C Vers. LCD		Data: 29/05/03	Codice Progetto: PFPJ500MC	
Autore: Ufficio Tecnico		Revisione: 2.0	Nome Parte: LCD Alarms Card Layout	
Nome PC in Rete: \\UT_SRV\PROGETTI		File/Cartella: MANUAL\PJ500M\LCD\SLPROTPJ-HCL\LAY_CPU.DJV		Codice: SLPROTPJ-HCL
Scala: 1:1	Materiale: /	Trattamento: /	Profilo: /	/

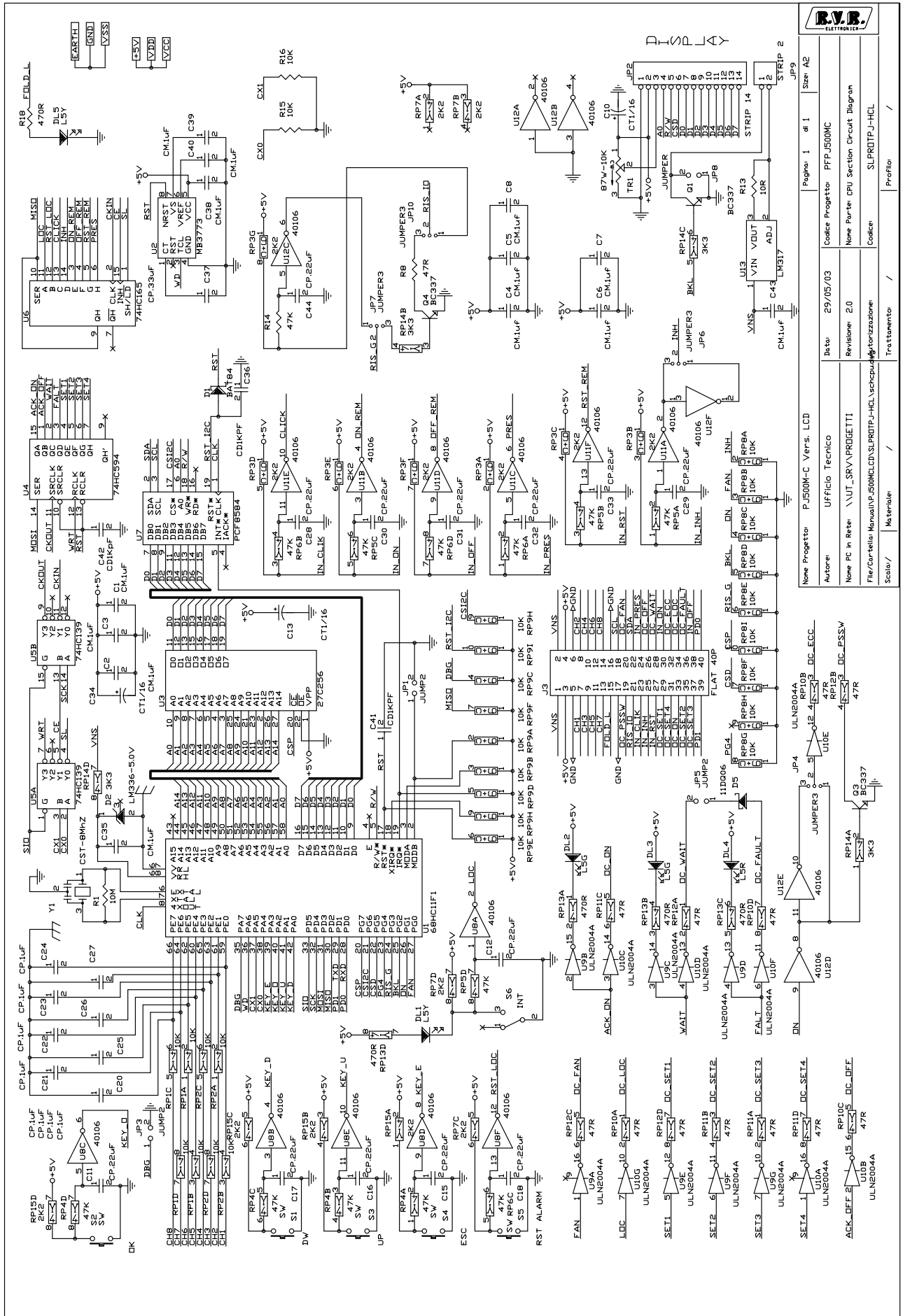

CPU Analog Section

SLPROTPJ-HCL

Version: 2.0 Date: 27/05/03

Item	Q.ty	Reference	Part
1	13	C1,C2,C3,C4,C5,C6,C7,C8,C35, C38,C39,C40,C43	CM.1UF
2	3	C10,C13,C34	CT1/16
3	13	C11,C12,C15,C16,C17,C18, C28,C29,C30,C31,C32,C33,C44	CP.22UF
4	8	C20,C21,C22,C23,C24,C25, C26,C27	CP.1UF
5	3	C36,C41,C42	CD1KPF
6	1	C37	CP.33UF
7	2	DL1,DL5	L5Y
8	2	DL2,DL3	L5G
9	1	DL4	L5R
10	1	D1	BAT84
11	1	D2	LM336-5.0V
12	1	D5	11DQ06
13	3	JP1,JP3,JP5	JUMP2
14	1	JP2	STRIP 14
15	4	JP4,JP6,JP7,JP10	JUMPER3
16	1	JP8	JUMPER
17	1	JP9	STRIP 2
18	1	J3	FLAT 40P
19	3	Q1,Q3,Q4	BC337
20	6	RP1,RP2,RP8,RP9,R15,R16	10K
21	3	RP3,RP7,RP15	2K2
22	4	RP4,RP5,RP6,R14	47K
23	4	R8,RP10,RP11,RP12	47R
24	2	RP13,R18	470R
25	1	RP14	3K3
26	1	R1	10M
27	1	R13	10R
28	5	S1,S2,S3,S4,S5	SW
29	1	S6	INT
30	1	TR1	87W-10K
31	1	U1	68HC11F1
32	1	U2	MB3773
33	1	U3	27C256
34	1	U4	74HC594
35	1	U5	74HC139
36	1	U6	74HC165
37	1	U7	PCF8584
38	3	U8,U11,U12	40106
39	2	U9,U10	ULN2004A
40	1	U13	LM317
41	1	Y1	CST-8MHZ

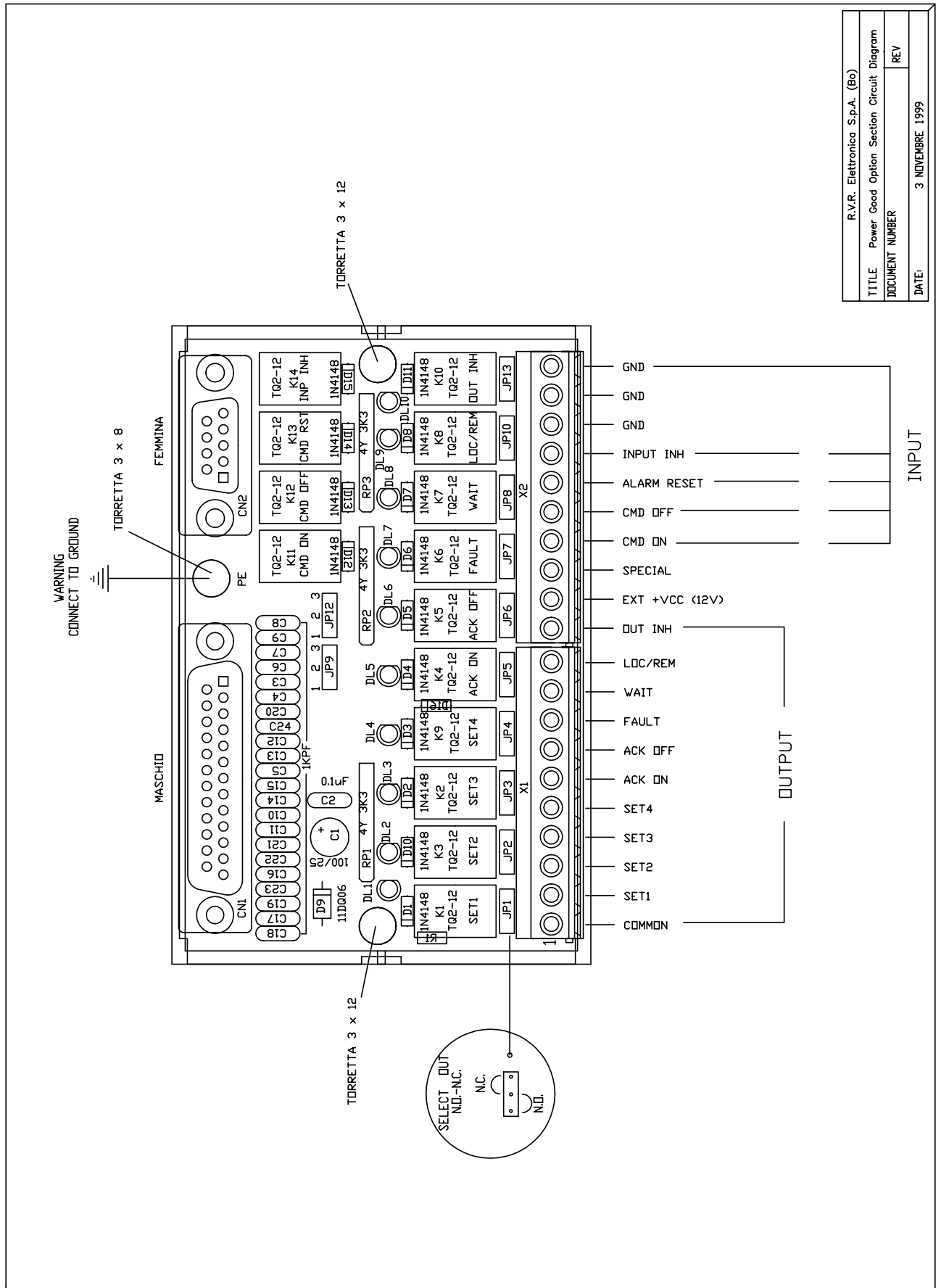

R.V.R. Elettronica S.p.A. (Bo)	
TITLE	Power Good Option Section Circuit Diagram
DOCUMENT NUMBER	REV
DATE:	3 NOVEMBRE 1999

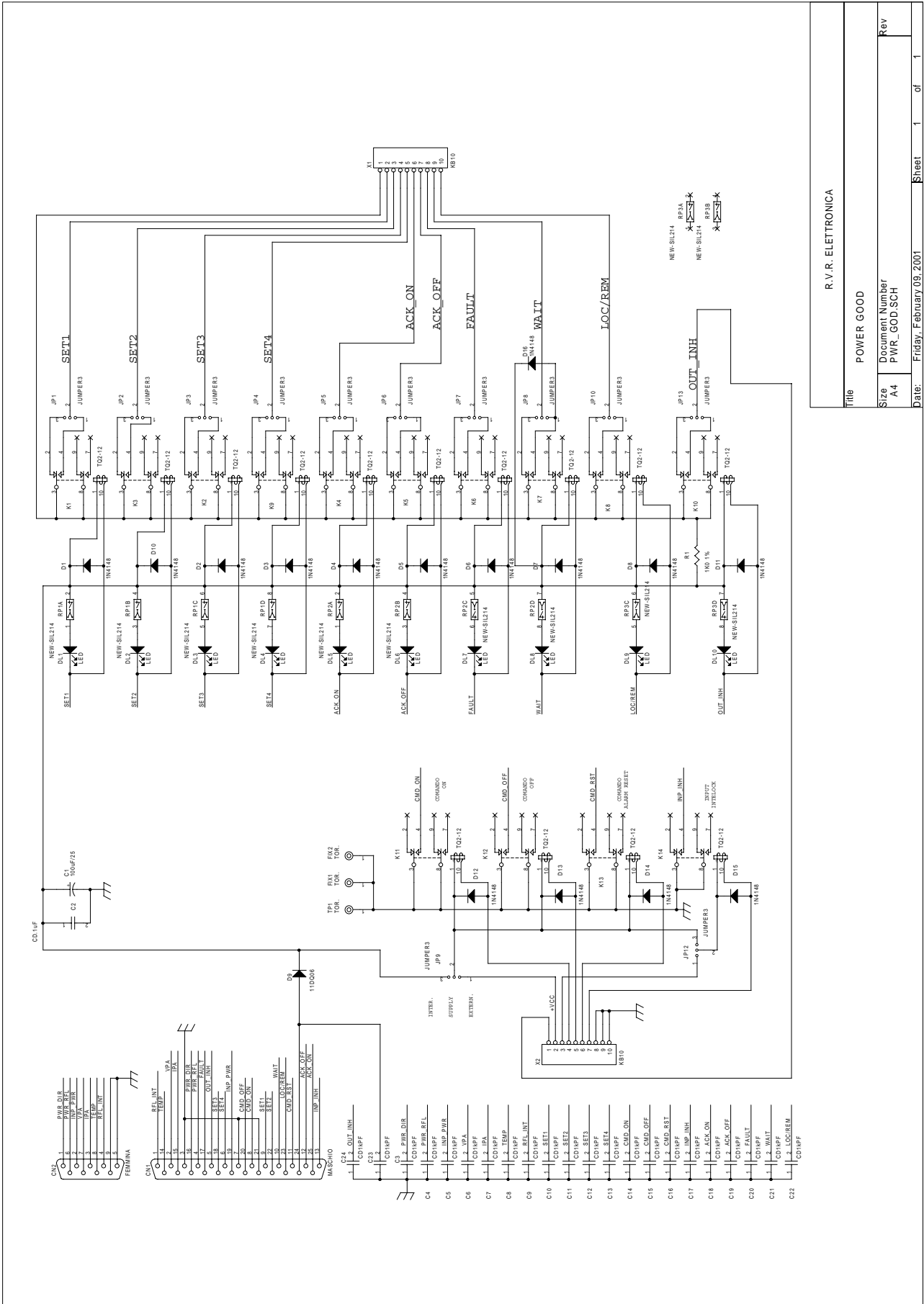

POWER GOOD Bill Of Materials Revised: November 25, 1999
 Item Q.ty Reference Part

1	1	CN1	MASCHIO
2	1	CN2	FEMMINA
3	1	C1	100UF/25
4	1	C2	CD.1UF
5	22	C3, C4, C5, C6, C7, C8, C9, C10, C11, C12, C13, C14, C15, C16, C17, C18, C19, C20, C21, C22, C23, C24	CD1KPF
6	10	DL1, DL2, DL3, DL4, DL5, DL6, DL7, DL8, DL9, DL10	LED
7	15	D1, D2, D3, D4, D5, D6, D7, D8, D10, D11, D12, D13, D14, D15, D16	1N4148
8	1	D9	11DQ06
9	3	TP1, FIX1, FIX2	TOR.
10	12	JP1, JP2, JP3, JP4, JP5, JP6, JP7, JP8, JP9, JP10, JP12, JP13	JUMPER3
11	14	K1, K2, K3, K4, K5, K6, K7, K8, K9, K10, K11, K12, K13, K14	TQ2-12
12	3	RP1, RP2, RP3	NEW-SIL214
13	2	X1, X2	KB10
14	1	R1	1K0 1%

Pagina lasciata intenzionalmente in bianco
This page was intentionally left blank

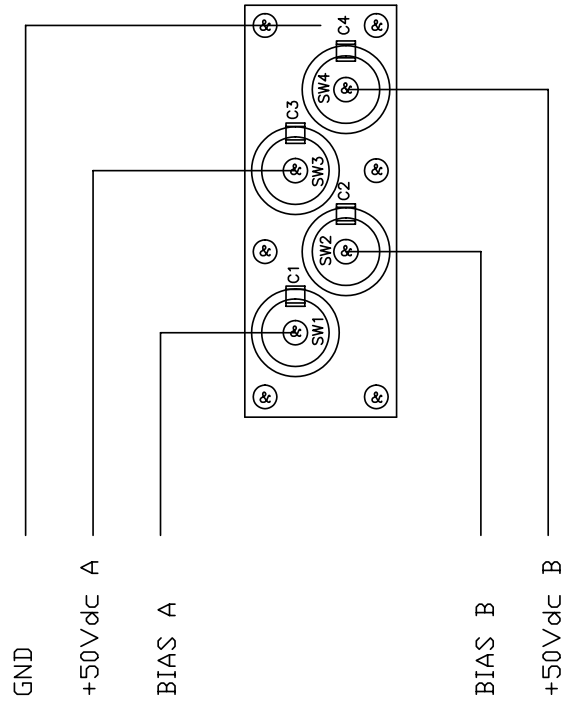

		Pagina 1	al 1	Size: A4	
Nome Progetto:	PJ500M-C LCD	Autore:	D'ALESSIO D.	Codice Progetto:	/
Autore:	D'ALESSIO D.	Nome PC in Rete:	\\JACK\	Revisione:	1.0
Nome PC in Rete:	\\JACK\	File/Cartella:	MANUALI\PJ500MCLDCSFLIPS\CSFILPS.DWG	Autore/Revisione:	SCHEDA VITTI PASSANTI
File/Cartella:	MANUALI\PJ500MCLDCSFLIPS\CSFILPS.DWG	Scala/	Materiali:	Trattamento:	CSFILPS
Scala/	Materiali:	Profilo:	/		

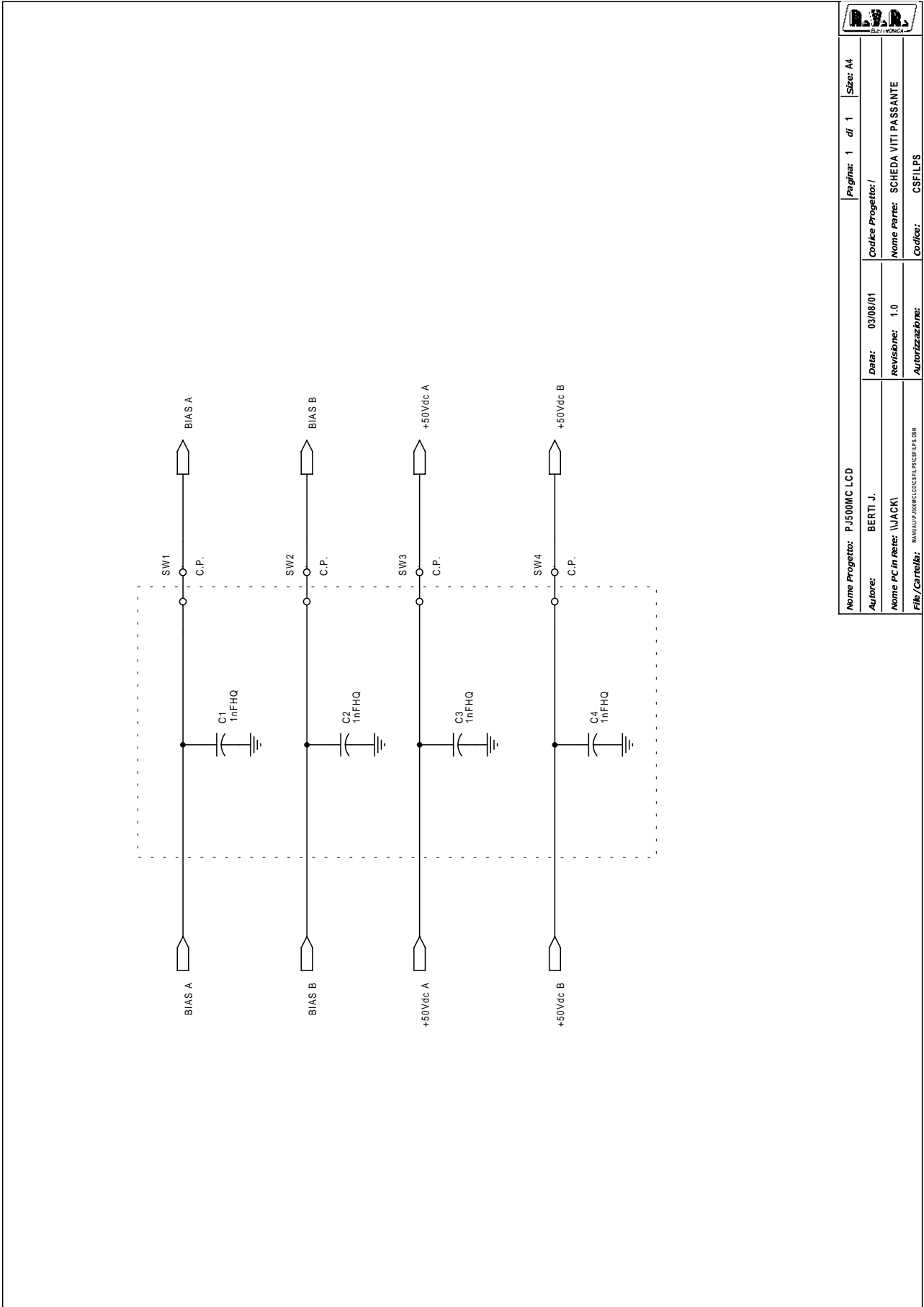

		Pagina: 1 di 1	Size: A4
Nome Progetto: PJ500M-C LCD		Codice Progetto: /	
Autore: BERTI J.	Data: 03/08/01	Nome Parte: SCHEDA VITI PASSANTE	
Nome PC in Rete: \\JACK1	Revisione: 1.0	Codific: CSFILPS	
File /Cartella: MANUALE PJ500M-C LCD (R.V.R. ELETTRONICA)	Autorizzaz.ione:	CSFILPS	

CSFILPS		Bill Of Materials		Page1
Item	Q.ty	Reference	Part	Description Part
1	4	C1, C2, C3, C4	1nFHQ	Cond. Chip HQ
2	4	SW1, SW2, SW3, SW4	C.P.	Viti passanti

Pagina lasciata intenzionalmente in bianco
This page was intentionally left blank

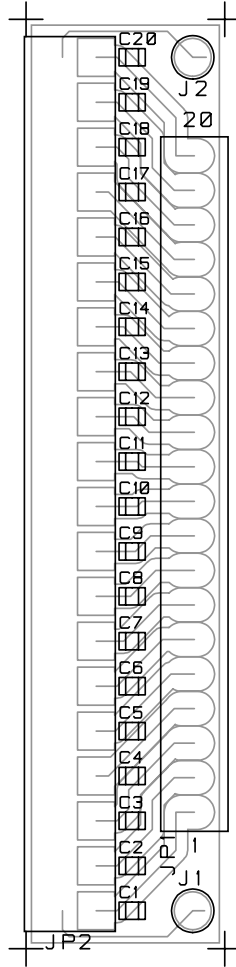

		Pagina 1 di 1	Size: A4
Nome Progetto: PJ500MC LCD	Codice Progetto: /	Data: 09/10/01	Nome Part: CONNETTIDRE INTERFACCIA PROTEZIONE
Autore: GRIPTECH - REV. BERTI J.	Revisione: 1.0	Autorizzazione:	Codice: CSADPCNPRTPJ
Nome PC in Rete: \\JACK\	Trattamento: /	Profilo: /	
File/Car-tella: MANUALPJ500MCLCD\FILTR EMALMIDVAG			
Scala: /			

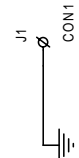
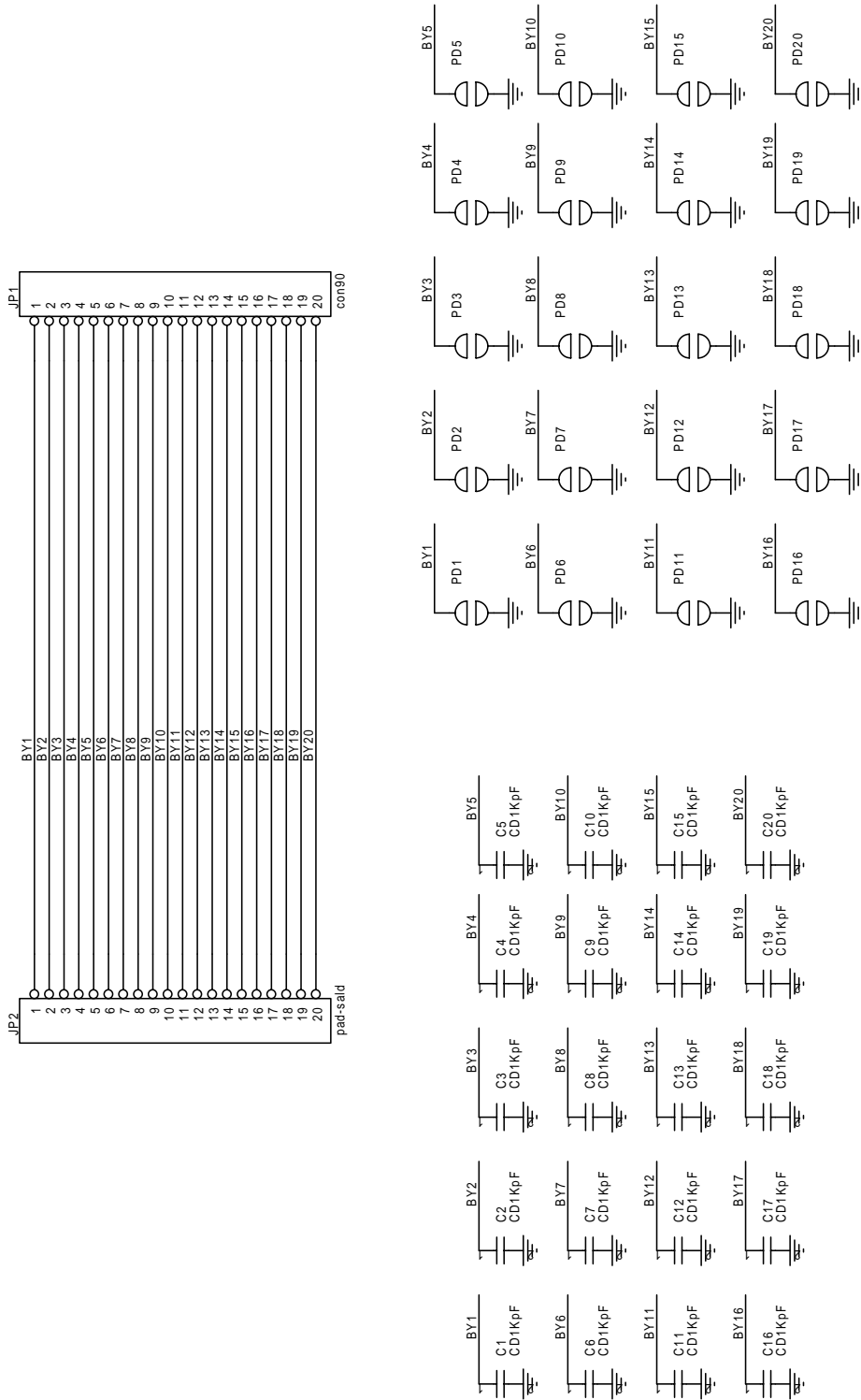

		Pagina: 1 di 1		Size: A4
Nome Progetto: PJ500M LCD		Codice Progetto: /		Nome Parte: CONNETTORE INTERFACCIA PROTEZIONI
Autore: REV.: BERTI J.		Data: 09/10/01		Nome PC in Rete: \\JACK1
File: Carrel\B\MANUALI\PJ500M\CDC\DIETR.EMIANA.CON.INDS		Revisione: 1.0		Config: CSADPCNPRTPJ
Autorizzazione:				

Item	Quantity	Reference	Part
1	20	C1	CD1KPF
		C2	CD1KPF
		C3	CD1KPF
		C4	CD1KPF
		C5	CD1KPF
		C6	CD1KPF
		C7	CD1KPF
		C8	CD1KPF
		C9	CD1KPF
		C10	CD1KPF
		C11	CD1KPF
		C12	CD1KPF
		C13	CD1KPF
		C14	CD1KPF
		C15	CD1KPF
		C16	CD1KPF
		C17	CD1KPF
		C18	CD1KPF
		C19	CD1KPF
		C20	CD1KPF
2	1	JP1	CON90
3	1	JP2	PAD-SALD
4	1	J1	CON1
5	20	PD1	
		PD2	
		PD3	
		PD4	
		PD5	
		PD6	
		PD7	
		PD8	
		PD9	
		PD10	
		PD11	
		PD12	
		PD13	
		PD14	
		PD15	
		PD16	
		PD17	
		PD18	
		PD19	
		PD20	

Pagina lasciata intenzionalmente in bianco
This page was intentionally left blank

ML/MN/MP SERIES: BULK POWER FRONT ENDS

800, 1000 & 1200 Watts: 24, 28 & 48 VDC with PFC



KEY FEATURES

- Cost Effective
- Active Power Factor Correction
- Meets EN61000-3-2
- Up to 7 Watts / Cu. Inch
- Class B Input EMI Filter
- Single-Wire Current Share
- No Minimum Load
- 85% Efficiency
- Remote Inhibit
- Remote Output Voltage Adjust
- Overvoltage Protection
- Overload & Short Circuit Protection
- Thermal Protection
- AC Power Fail & DC Power Good
- 12V, 500mA Standby Output
- 5V, 100mA Standby Output



TWO-YEAR WARRANTY

STANDARD MODELS

(Other Outputs Available, Consult Factory)

MAX WATTS	OUTPUT VOLTAGE	OUTPUT CURRENT	PFC	MINIMUM LOAD	TOTAL REGULATION	MODEL NUMBER	INPUT VOLTAGE
800	24V	33A	✓	0A	1%	ML5000	85-264VAC
800	28V	29A	✓	0A	1%	ML6000	85-264VAC
800	48V	17A	✓	0A	1%	ML7000	85-264VAC
1000	24V	42A	✓	0A	1%	MN5000	85-264VAC
1000	28V	36A	✓	0A	1%	MN6000	85-264VAC
1000	48V	21A	✓	0A	1%	MN7000	85-264VAC
1200	24V	50A	✓	0A	1%	MP5000	170-264VAC
1200	28V	43A	✓	0A	1%	MP6000	170-264VAC
1200	48V	25A	✓	0A	1%	MP7000	170-264VAC

For modified versions, call our Modification Center at 954-346-2442 Ext. 400

SAFETY CERTIFICATIONS

AGENCY	STANDARD
UL	UL1950
CUL	CSA22.2, No. 950
DEMKO	EN60-950

www.unipower-corp.com or www.powerspeed.com

Copyright © 2000 Unipower Corporation. All rights reserved.



SPECIFICATIONS, ML/MN/MP SERIES

Typical at Nominal 115/230VAC Line, Full Load and 25°C Unless Otherwise Noted.

OUTPUT SPECIFICATIONS

Voltage Adjustment Range	±5%
Total Regulation ¹	1.0%
Ripple & Noise, Pk-Pk ²	1%
Holdup	15mS
Dynamic Response ³	300µS
Temperature Coefficient	±0.02%/°C
Minimum Load	0A
Overload Protection	Constant Current Limiting
Overvoltage Protection	Power Shutdown
Remote Sense	Up to 0.25V Per Wire

INPUT SPECIFICATIONS

Input Voltage Range	85-264VAC, Single Phase
Power Factor	0.99
Input Frequency	47-63Hz
Inrush Limiting	30A Peak
Input Current, Full Load	
800W	7.9A, 120VAC; 4.1A, 230VAC
1000W	9.9A, 120VAC; 5.2A, 230VAC
1200W	6.2A, 230VAC
Input EMI Filter, Conducted	EN55022 Curve B FCC20780 pt. 15J Curve B
Harmonic Distortion	EN61000-3-2
Input Immunity, Conducted	
Fast Transients, Line-Line	±2kV (EN610000-4-4 Level 3)
Surges, Line-Line	±2kV (EN610000-4-5 Level 2)
Surges, Line-Ground	±2kV (EN610000-4-5 Level 3)
Input Protection	Internal Fuse

GENERAL SPECIFICATIONS

Efficiency	85% at Full Load
Switching Frequency	150kHz Nominal
Isolation, class 1 ⁴	3000VAC Input - Output >1500VAC Input - Ground >50VDC Output - Ground
Safety Standards	EN60-950, UL1950, CSA22.2-950

ENVIRONMENTAL SPECIFICATIONS

Operating Temperature	0°C to 70°C Ambient
Derating	2.5% / °C, 50°C to 70°C
Storage Temperature	-40°C to +85°C
Cooling	Integral Ball Bearing Fans

PHYSICAL SPECIFICATIONS

Case Material	Aluminum
Dimensions, Inches(mm)	3.25 H x 5 W x 10.5 D (82.6 x 127 x 267)

NOTES:

- No load to full load, including line regulation and load regulation.
- Whichever is greater, 20MHz bandwidth. Measured with 0.1µF ceramic and 10µF tantalum capacitors in parallel across the output.
- <4% deviation recovering to within 1% for 25% load change.
- Input - output isolation figure is for isolation components only. 100% production Hipot tested.

J1 CONTROL & SUPERVISORY SIGNALS			
PIN	FUNCTION	PIN	FUNCTION
1	+Sense	6	DC Power Good
2	-Sense	7	Inhibit (N.O.)
3	Remote Adjust	8	Not Used
4	Not Used	9	AC Power Fail
5	Current Share	10	Control Common

J2: 12V, 500mA STANDBY SUPPLY	
PIN	FUNCTION
1	12V Return
2	+12VDC

J3: 5V, 100mA STANDBY SUPPLY	
PIN	FUNCTION
1	+5VDC
2	5V Return

CONNECTORS	
J1: AMP 173981-0	10-PIN
J2: LMI 9105.102.02	2-PIN
J3: AMP 171825-2	2-PIN

MATING CONNECTOR KIT	
Kit provides mating connectors for all ML, MN and MP Series models.	
Order Kit No.: 775-1417-000	\$8.00

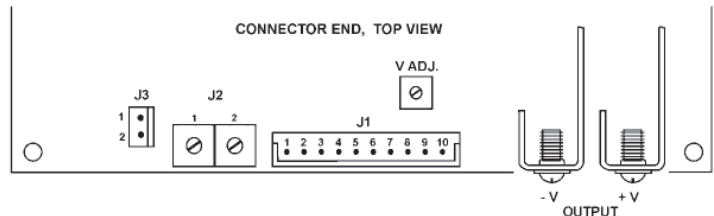

CASE OUTLINE

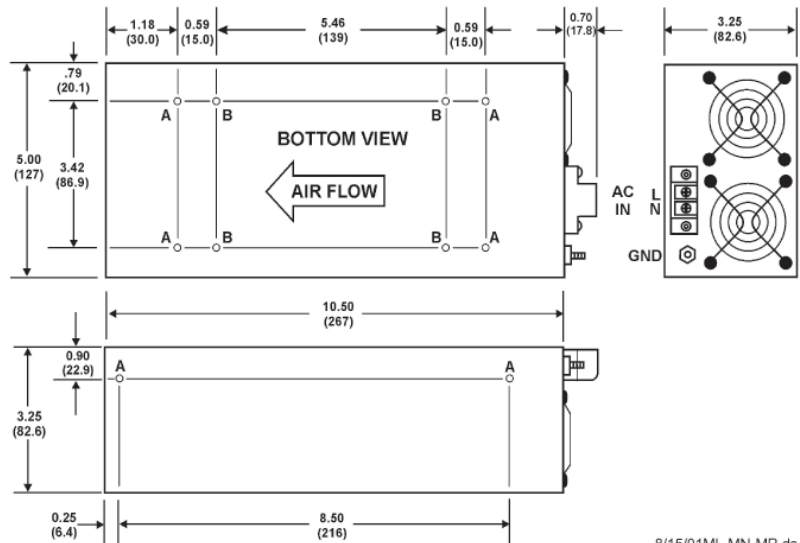

NOTE:

"A" Mounting holes are No. 6-32 threaded inserts. "B" mounting holes are M3 threaded inserts. Max. penetration is 0.25" (6.4mm).

ALL DIMENSIONS IN INCHES (mm).
All specifications subject to change without notice.

8/15/01ML-MN-MP-ds

DIV. OF UNIPOWER CORP. • 3900 Coral Ridge Drive, Coral Springs, Florida 33065, UNITED STATES • Tel: 954-346-2442 • Fax: 954-340-7901 • sales@unipower-corp.com
UNIPOWER EUROPE • Parkland Business Centre, Chartwell Road, Lancing, BN158UE, ENGLAND • Tel: +44(0)1903768200 • Fax: +44(0)1903764540 • info@unipower-europe.com

Appendix B PFC Power Supply Option

This appendix describes the Option PFC power supply section of the PJ500M-C amplifier. This power supply section substitutes the standard transformer/switching power supply of the amplifier, and its main features are:

- *Active power factor correction*
- *Direct from mains power supply (no transformer)*

*The use of this option requires a low distortion mains supply. **For this reason it is not suitable for use with e.g. diesel power generators or certain kinds of UPS.***

The appendix contains the wiring diagram of the machine, the schematics and PCB layout of all the boards of the PJ500M-C fitted with this option, plus the photograph of the concerned parts:

Description	RVR Code	Vers.	
	Pages		
Wiring diagrams	Wiring diagrams	1.0	2
PFC board	CSPFC1000PW1	1.0	10
Power Supply section	CPSL1000PW2	1.0	10

Modules Identification (top view)



- [1] P.F.C. Rectifier (PFC1000)
- [2] Power Supply 1 (PSL1000)
- [3] Power Supply 2 (PSL1000)

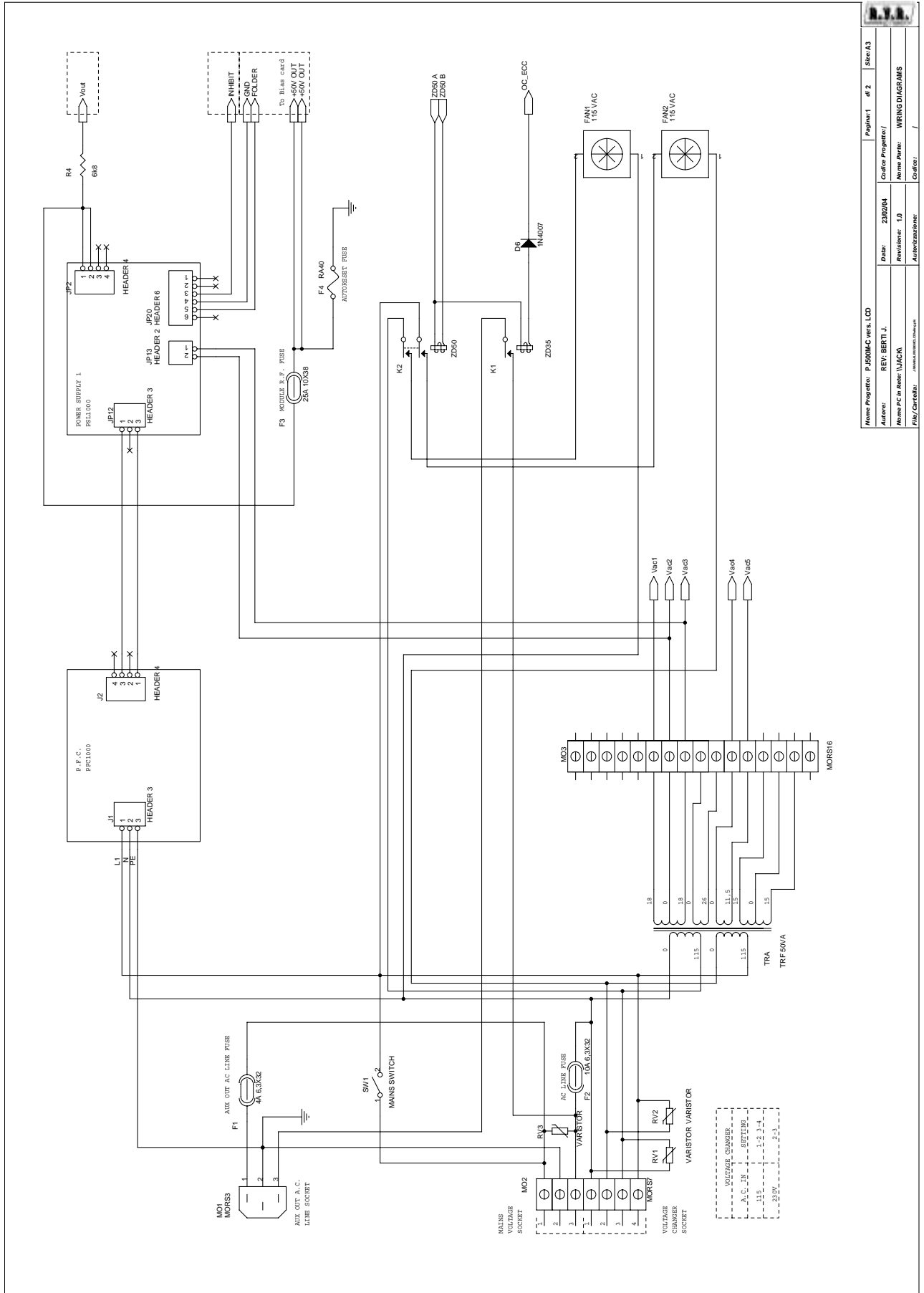

Nome Progetto: PJ500M-C vers. LCD		Page: 1	di 2	Struc: A3
Autore:	REV. BERTI J.	Data:	23/02/04	Codice Progetto/
Nome PC in Rete: NJACK	Revisione: 1.0	WIRING DIAGRAMS		
File/Caricatore:	Autore/Disegnatore:	Codice:		

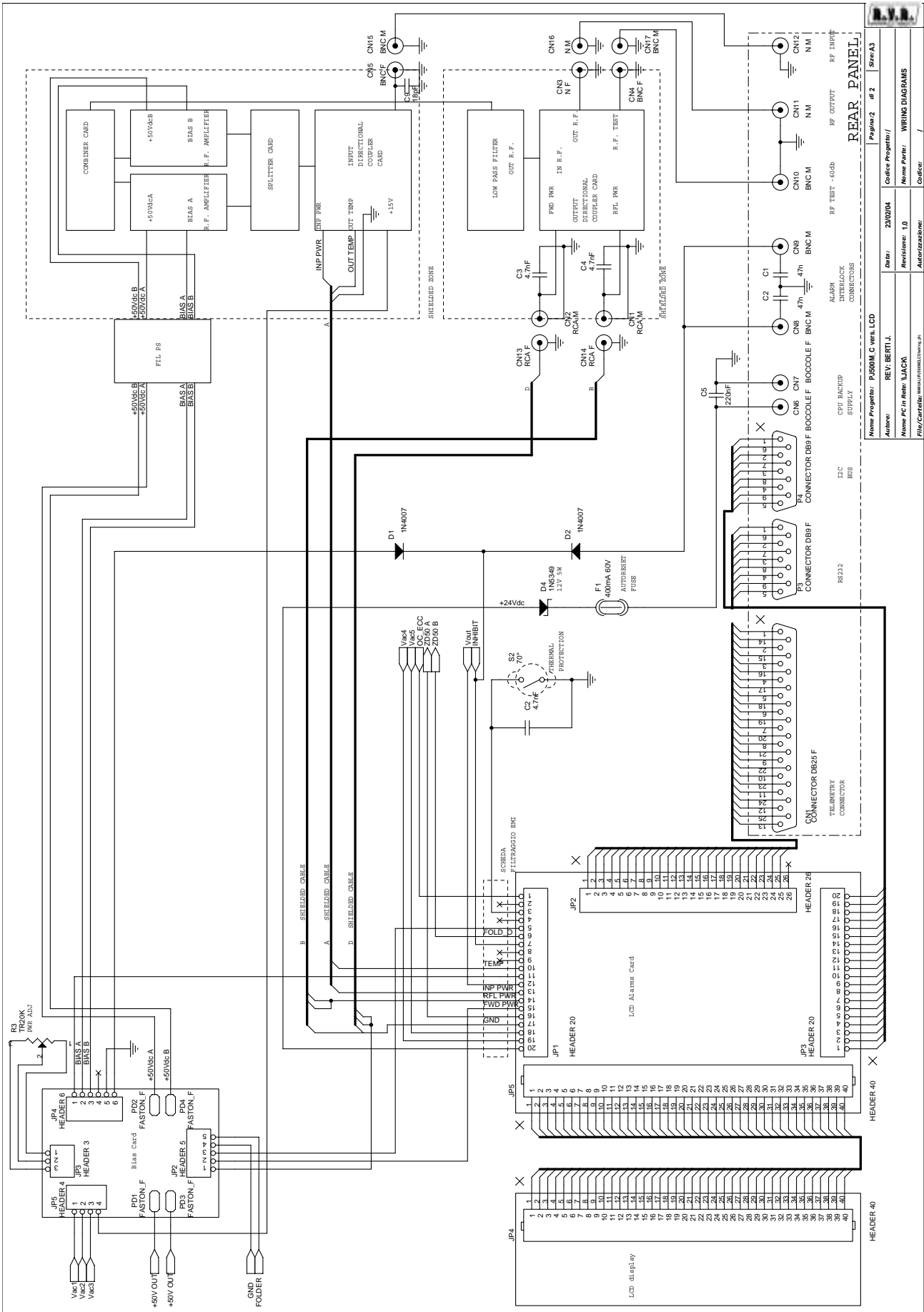

R.V.R. ELETTRONICA	
Nome Progetto: PJ500M C vers. LCD	Reviziona: 1.0
Autore: REV:BERT J.	Autore: NOME
Nome PC in Rete: N/A/C/A	Reviziona: 1.0
File/Caratteristiche: www.rvr.com/eng/eng.htm	Autore: NOME
Nome Progetto: PJ500M C vers. LCD	Reviziona: 1.0
Autore: REV:BERT J.	Autore: NOME
Nome PC in Rete: N/A/C/A	Reviziona: 1.0
File/Caratteristiche: www.rvr.com/eng/eng.htm	Autore: NOME

Nome Progetto: PJ500M C vers. LCD	Reviziona: 1.0
Autore: REV:BERT J.	Autore: NOME
Nome PC in Rete: N/A/C/A	Reviziona: 1.0
File/Caratteristiche: www.rvr.com/eng/eng.htm	Autore: NOME
Nome Progetto: PJ500M C vers. LCD	Reviziona: 1.0
Autore: REV:BERT J.	Autore: NOME
Nome PC in Rete: N/A/C/A	Reviziona: 1.0
File/Caratteristiche: www.rvr.com/eng/eng.htm	Autore: NOME

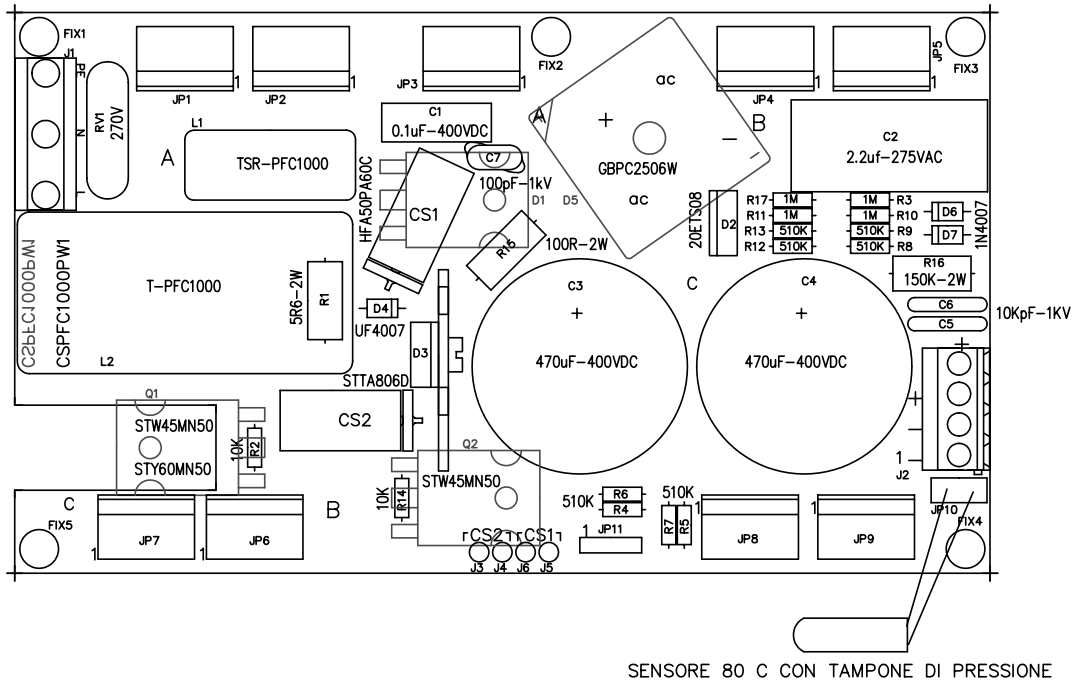

	NOME PROGETTO: PJ500M-C vers. LCD	NOME PARTE: PIANO DI MONTAGGIO POWER PFC				
	AUTORE: U.T. - REV.: BERTI J.	DATA: 20/04/2003	REVISIONE: 1.0	SCALA: 1:1	SIZE: A4	PAGINA: 1 DI 3
ARCHIVIAZIONE ELETTRONICA: "CARTELLA PROGETTI" SU "UT_SRV"		CODICE PROGETTO: /	CODICE DISEGNO: CSPFC1000PW1			
MATERIALE: /	TRATTAMENTO: /	PROFILO: /	STATO: <>			

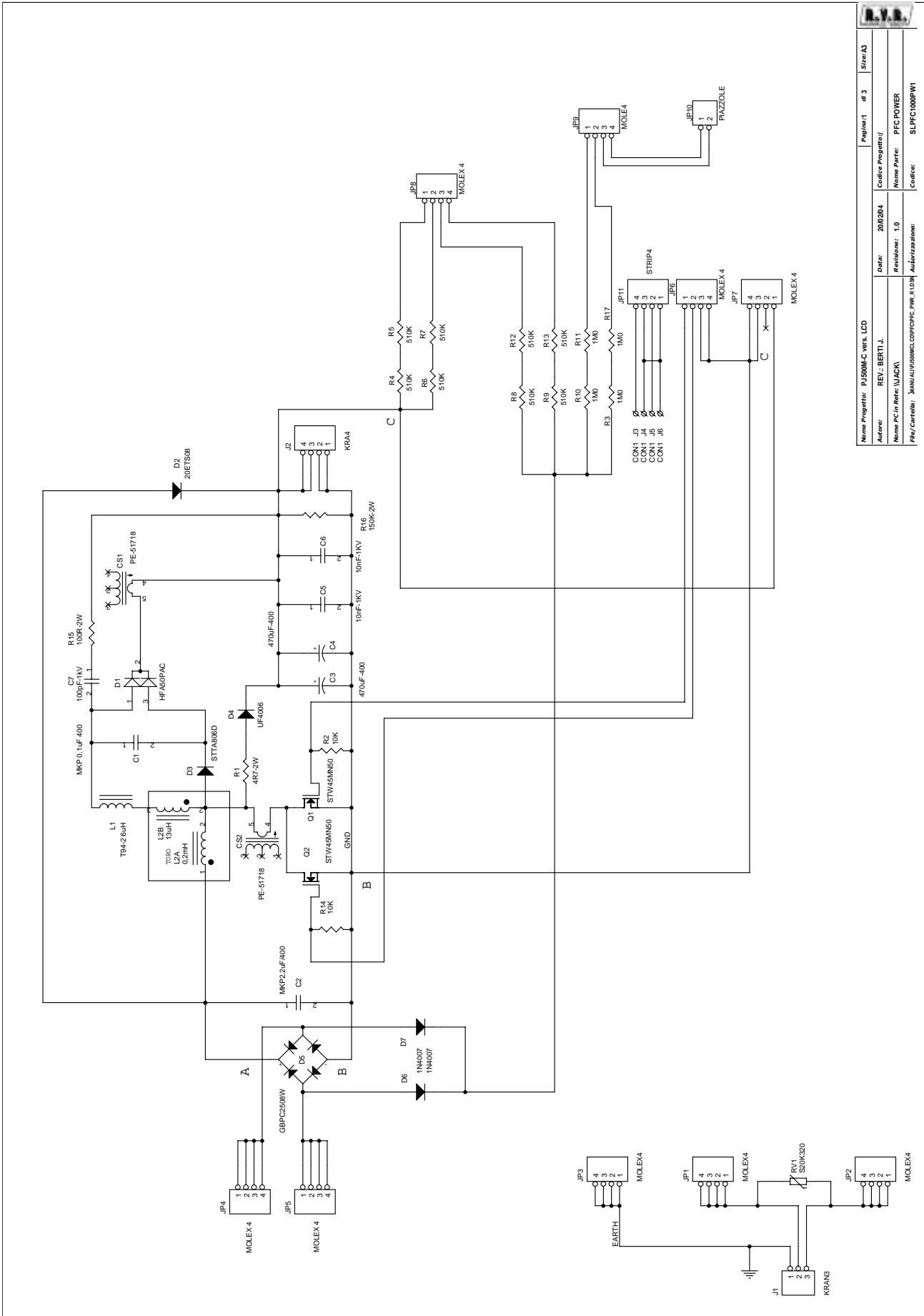

R.V.A.		Nome Progetto:	PJ500M-C vrs. LCD	Page/nr:1	di 3	Size: A3
Address:	REV.: BERT.J.	Data:	20/02/04	Code Progetto/		
Nome PC in Rete: UJACK		Revisione:	1.0	Nome Parte:	PFC POWER	
File/Caratteri:	X:\M\UJ\900M\CS\FPC\PC_PWR_8.1038	Autore/azione:		Codice:	SLPFC1000PW1	

Revised: Friday, February 20, 2004

Revision:

Item	Quantity	Reference	Part
1	2	CS2, CS1	PE-51718
2	1	C1	MKP 0.1uF 400
3	1	C2	MKP2.2uF/400
4	2	C4, C3	470uF-400
5	2	C5, C6	10nF-1KV
6	1	C7	100pF-1kV
7	1	D1	HFA50PAC
8	1	D2	20ETS08
9	1	D3	STTA806D
10	1	D4	UF4006
11	1	D5	GBPC2508W
12	2	D7, D6	1N4007
13	3	JP1, JP2, JP3	MOLEX4
14	5	JP4, JP5, JP6, JP7, JP8	MOLEX 4
15	1	JP9	MOLE4
16	1	JP10	PIAZZOLE
17	1	JP11	STRIP4
18	1	J1	KRAN3
19	1	J2	KRA4
20	4	J3, J4, J5, J6	CON1
21	1	L1	T94-2 6uH
22	1	L2	0,2mH
23	2	Q2, Q1	STW45MN50
24	1	RV1	S20K320
25	1	R1	4R7-2W
26	2	R14, R2	10K
27	4	R3, R10, R11, R17	1M0
28	8	R4, R5, R6, R7, R8, R9, R12, R13	510K
29	1	R15	100R-2W

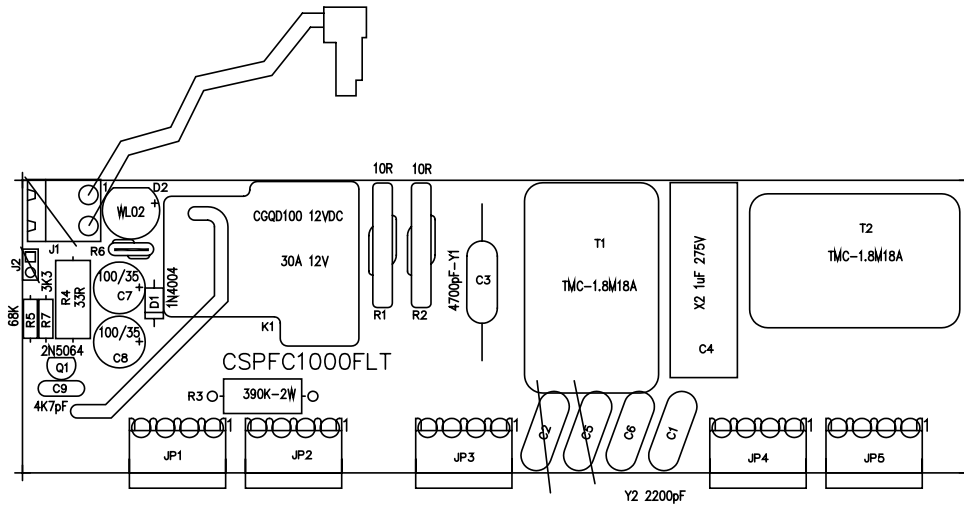

	NOME PROGETTO: PJ500M-C vers. LCD	NOME PARTE: PIANO DI MONTAGGIO SEZIONE FILTRO SOFT S.			
	AUTORE: U.T. - REV.: BERTI J.	DATA: 20/04/2003	REVISIONE: 1.0	SCALA: 1:1	SIZE: A4
ARCHIVIAZIONE ELETTRONICA: "CARTELLA PROGETTI" SU "UT_SRV"		CODICE PROGETTO: /	CODICE DISEGNO: CSPFC1000FLT		
MATERIALE: /	TRATTAMENTO: /	PROFILO: /	STATO: <>		

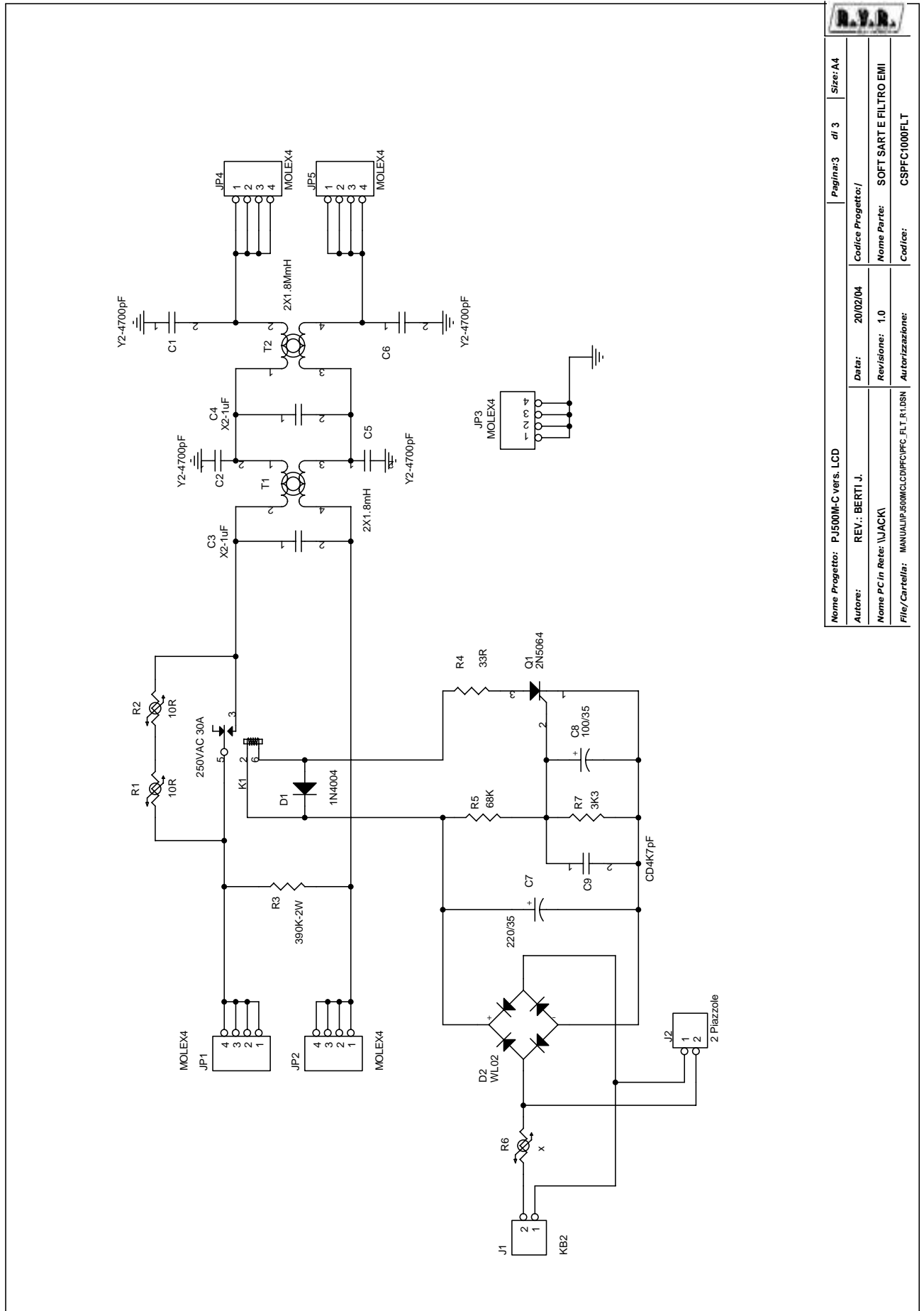

Nome Progetto: PJ500M-C vers. LCD		Pagina: 3	di 3	Size: A4
Autore: BERTI J.	REV.: BERTI J.	Data: 20/02/04	Codice Progetto: /	
Nome PC in Rete: \JACK1	Revisione: 1.0	Nome Parte: SOFT SART E FILTRO EMI		
File/ Cartella: MANUALPJ500MCLCDPFCIPC_FLT_R1.DSN	Autorizzazione:	Codice: CSPFC1000FLT		

Revised: Friday, February 20, 2004

Revision:

Item	Quantity	Reference	Part
1	4	C1, C2, C5, C6	Y2-4700pF
2	2	C4, C3	X2-1uF
3	1	C7	220/35
4	1	C8	100/35
5	1	C9	CD4K7pF
6	1	D1	1N4004
7	1	D2	WL02
8	5	JP1, JP2, JP3, JP4, JP5	MOLEX4
9	1	J1	KB2
10	1	J2	2 Piazzole
11	1	K1	250VAC 30A
12	1	Q1	2N5064
13	2	R2, R1	10R
14	1	R3	390K-2W
15	1	R4	33R
16	1	R5	68K
17	1	R6	x
18	1	R7	3K3
19	1	T1	2X1.8mH
20	1	T2	2X1.8MmH

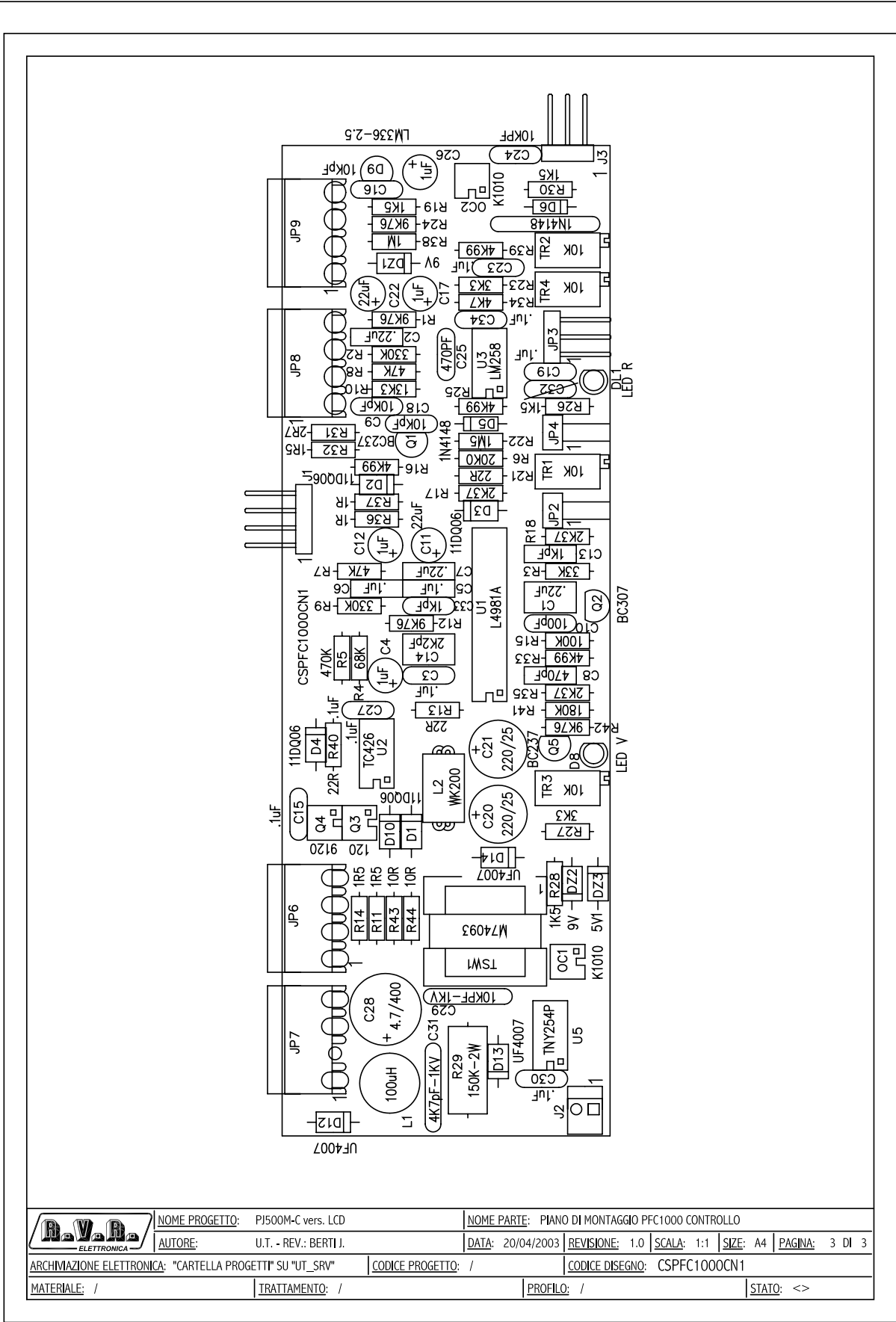

NOME PROGETTO: PJ500M-C vers. LCD	NOME PARTE: PIANO DI MONTAGGIO PFC1000 CONTROLLO
AUTORE: U.T. - REV.: BERTI J.	DATA: 20/04/2003
REVISIONE: 1.0	SCALA: 1:1
SIZE: A4	PAGINA: 3 DI 3
ARCHIVIAZIONE ELETTRONICA: "CARTELLA PROGETTI" SU "UT_SRV"	CODICE PROGETTO: /
CODICE DISEGNO: CSPFC1000CN1	
MATERIALE: /	TRATTAMENTO: /
PROFILO: /	STATO: <>

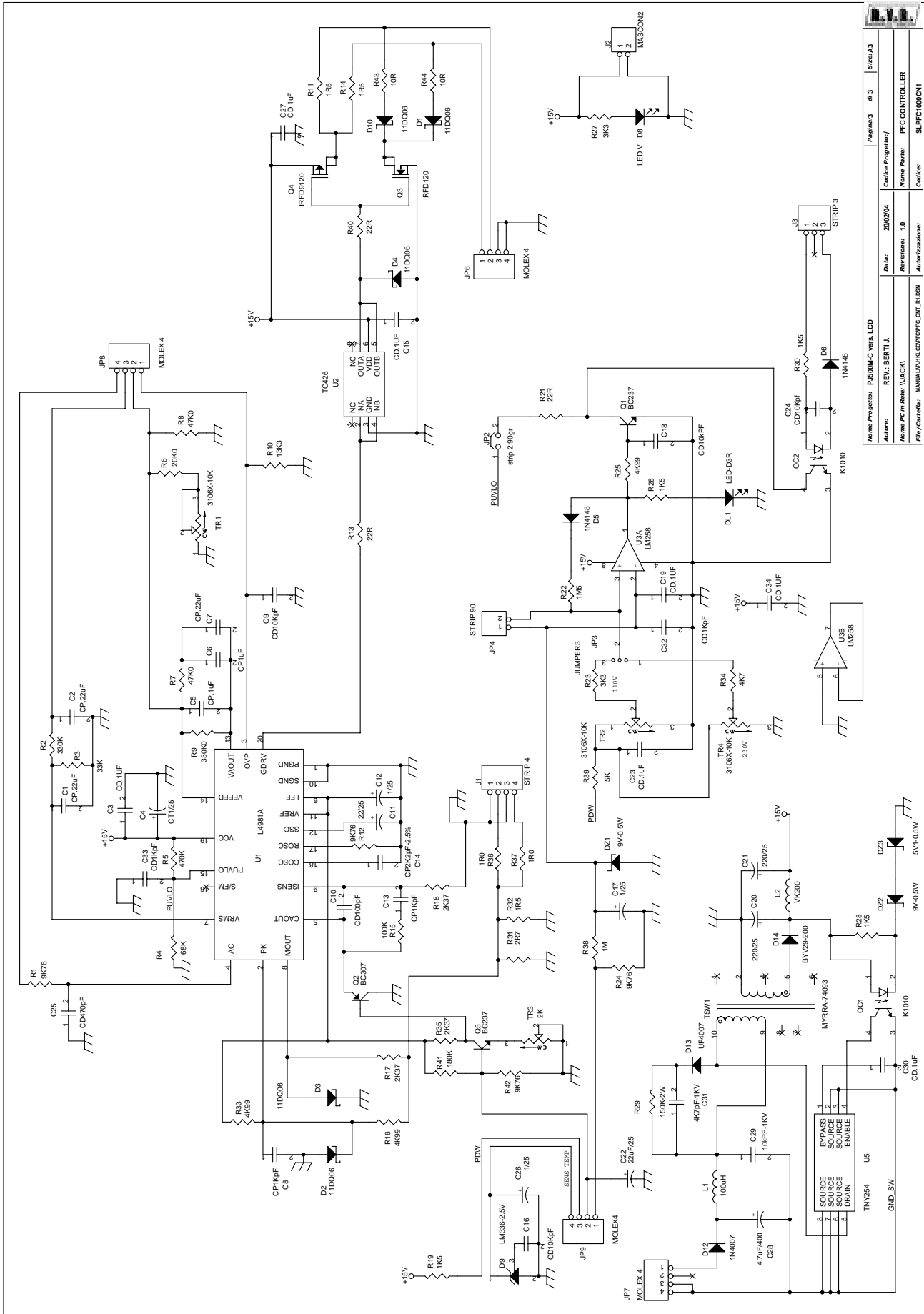

Nome Progetto: PJ500M-C v1.0		Page: 3	d: 3	Size: A3
Autore: REV. BERTI J.		Codice Progetto: /		
Nome P.C. in Rete: UACCA		Data: 20/02/04		
File/Carrello: MANUAPP/HLDDP/PFC/ONT_R1/03N		Revisione: 1.0		
		Nome Parte: PFC CONTROLLER		
		Codice: SLPFC1000CH1		

Revised: Friday, February 20, 2004

Revision:

Item	Quantity	Reference	Part
1	3	C1, C2, C7	CP.22uF
2	7	C3, C15, C19, C23, C27, C30, C34	CD.1uF
3	1	C4	CT1/25
4	1	C5	CP.1uF
5	1	C6	CP1uF
6	2	C8, C13	CP1KpF
7	4	C9, C16, C18, C24	CD10Kpf
8	1	C10	CD100pF
9	1	C11	22/25
10	3	C12, C17, C26	25-gen
11	1	C14	CP2K2pF-2.5%
12	2	C21, C20	220/25
13	1	C22	22uF/25
14	1	C25	CD470pF
15	1	C28	4.7uF/400
16	1	C29	10kPF-1KV
17	1	C31	4K7pF-1KV
18	2	C33, C32	CD1KpF
19	1	DL1	LED-D3R
20	2	DZ1, DZ2	9V-0.5W
21	1	DZ3	5V1-0.5W
22	5	D1, D2, D3, D4, D10	11DQ06
23	2	D6, D5	1N4148
24	1	D8	LED V
25	1	D9	LM336-2.5V
26	1	D12	1N4007
27	1	D13	UF4007
28	1	D14	BYV29-200
29	1	JP2	strip 2 90gr

Pagina lasciata intenzionalmente in bianco
This page was intentionally left blank

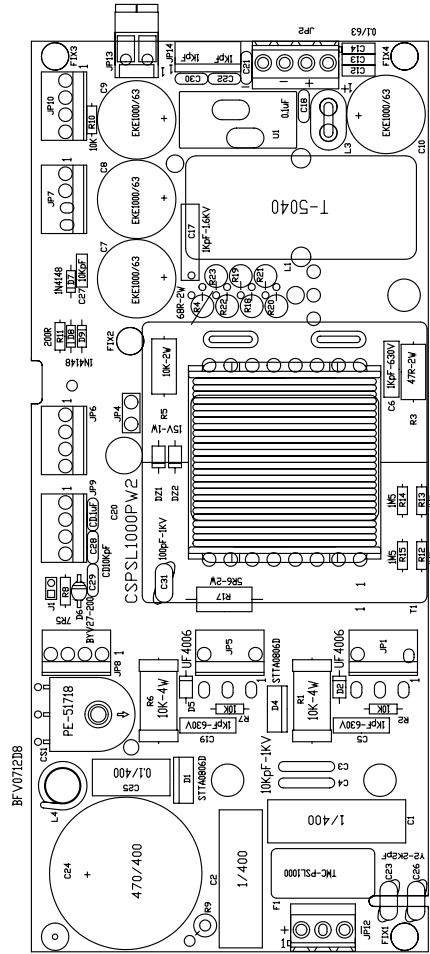

	NOME PROGETTO: PJ500M vers. LCD AUTORE: U.T. - rev.: I. Berti ARGOMINIZIONE ELETTRONICA: "CARTELLA PROGETTI SU 'UI_50W"	NOME ESATTE: PIANO DI MONTAGGIO SEZIONE POWER PSL1000 DATA: 20/02/04 REVISIONE: 1.0 SCALA: 1:1 SIZE: A3	PAGINA: 1 DI 3
MATERIALE: /	TRATTAMENTO: /	CODICE PROGETTO: /	CODICE DISEGNO: CSPSL1000PW2
PROFILO: /	STATO: /		

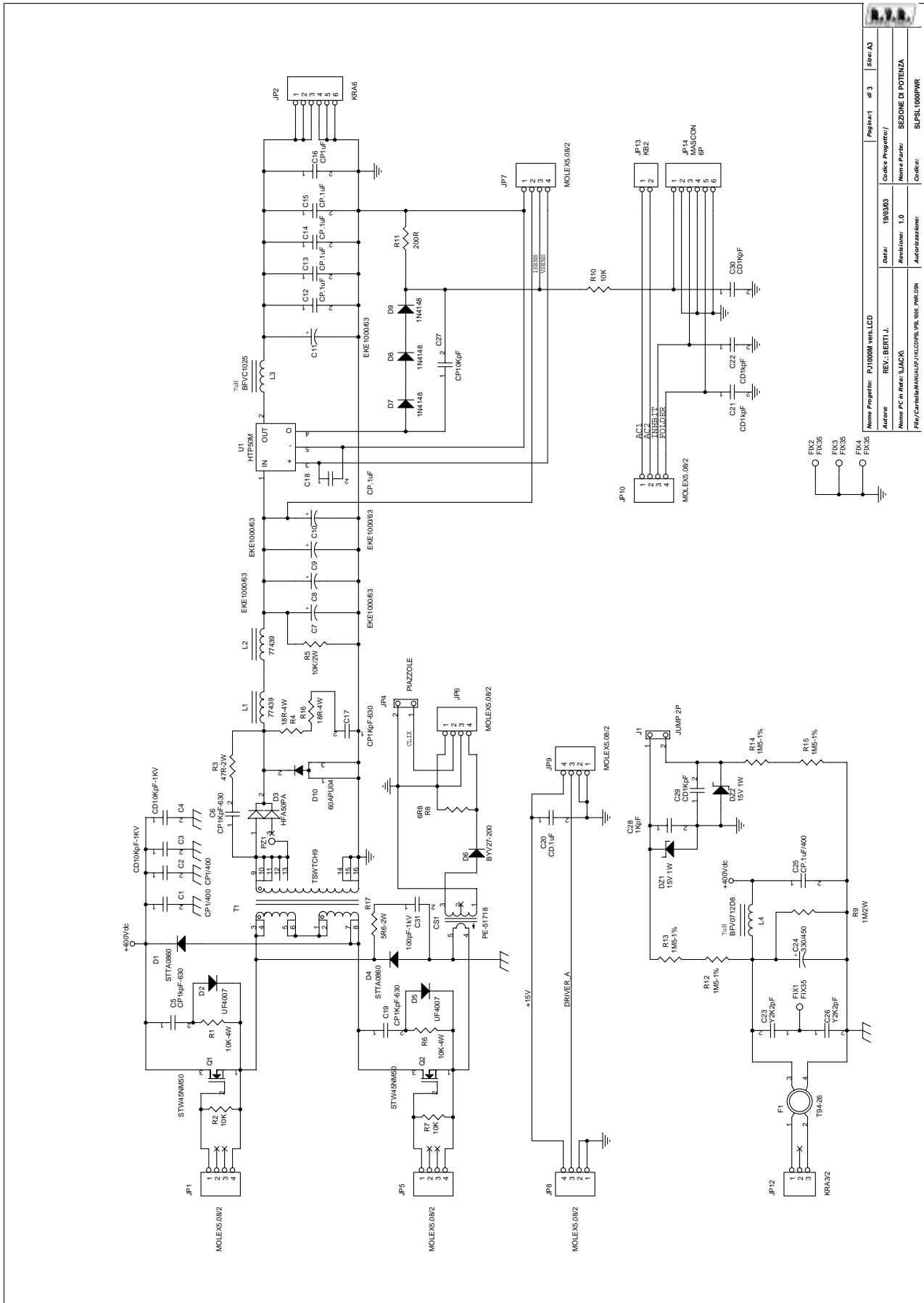

Revised: Monday, February 23, 2004

Revision:

Item	Quantity	Reference	Part
1	1	CS1	PE-51718
2	2	C2, C1	CP1/400
3	2	C4, C3	CD10KpF-1KV
4	4	C5, C6, C17, C19	CP1KpF-630
5	4	C7, C8, C9, C10	1000/63
6	4	C12, C13, C14, C18	CP.1uF
7	1	C20	CD.1uF
8	3	C21, C22, C30	CD1KpF
9	2	C26, C23	Y2K2pF
10	1	C24	330/450
11	1	C25	CP.1uF/400
12	1	C27	CP10KpF
13	1	C28	10KpF
14	1	C29	CD10KpF
15	1	C31	100pF-1kV
16	2	DZ1, DZ2	15V 1W
17	2	D4, D1	STTA0860
18	2	D5, D2	UF4007
19	1	D3	HFA50PA
20	1	D6	BYV27-200
21	3	D7, D8, D9	1N4148
22	4	FIX1, FIX2, FIX3, FIX4	FIX35
23	1	F1	T94-26
24	7	JP1, JP5, JP6, JP7, JP8, JP9, JP10	MOLEX5.08/2
25	1	JP2	KRA4
26	1	JP4	PIAZZOLE
27	1	JP12	KRA3/2
28	1	JP13	KB2
29	1	JP14	MASCON

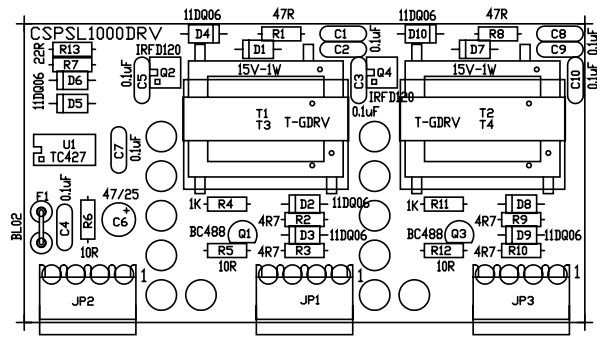

	NOME PROGETTO: PJ500M-C vers. LCD	NOME PARTE: PIANO DI MONTAGGIO SEZIONE DRIVER			
	AUTORE: U.T. - REV.: BERTI J.	DATA: 20/04/2003	REVISIONE: 1.0	SCALA: 1:1	SIZE: A4
ARCHIVIAZIONE ELETTRONICA: "CARTELLA PROGETTI" SU "UT_SRV"		CODICE PROGETTO: /	CODICE DISEGNO: CSPSL1000DRV		
MATERIALE: /	TRATTAMENTO: /	PROFILO: /	STATO: <>		

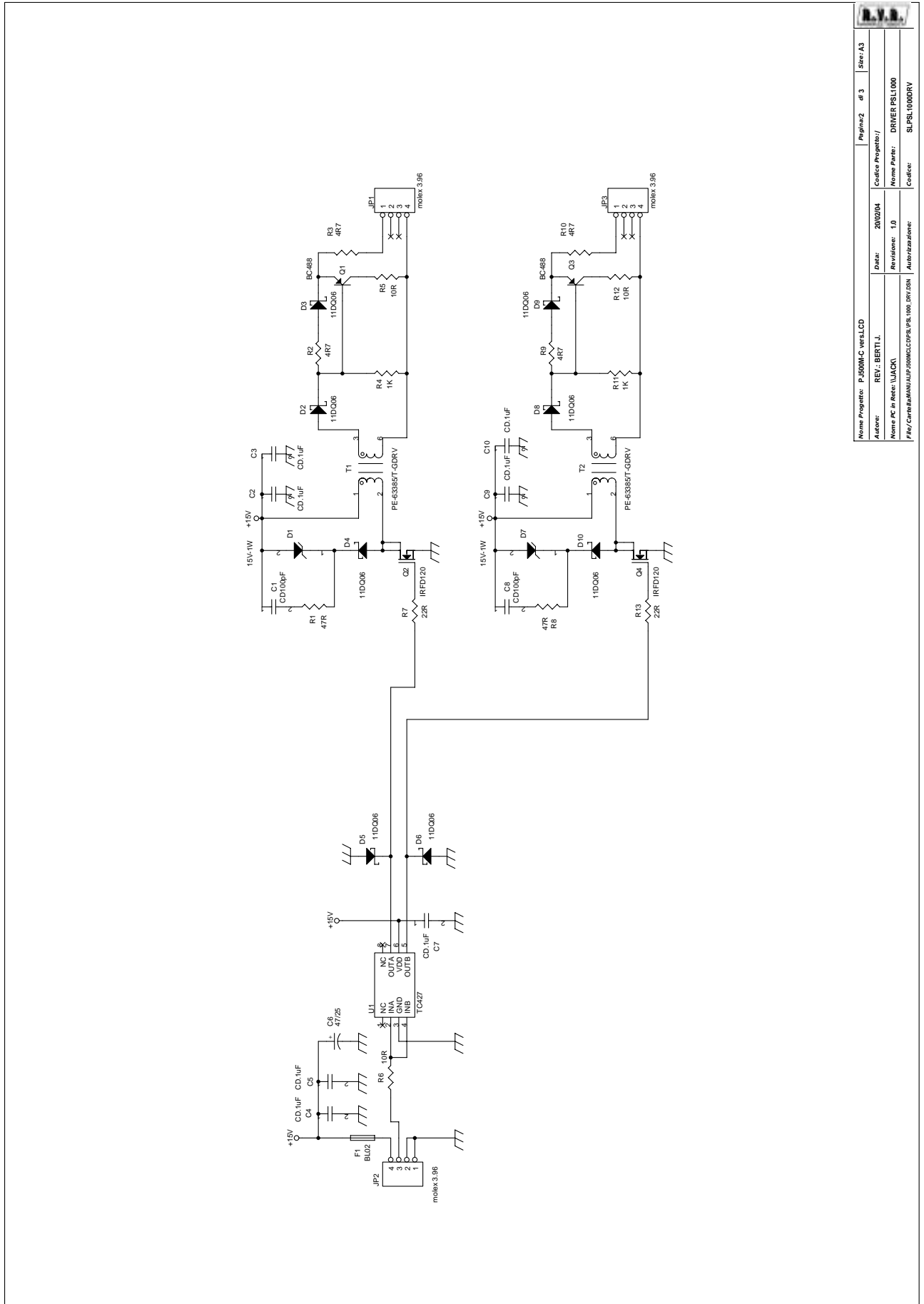

R.V.R.	
Nome Progetto:	PJ500M-C versLCD
Autore:	REV. BERTI J.
Nome PC in Rete:	NAJACK
File/Caricamento:	1000MCLCDPSL1000.DRV/DSN
Colore Progetto:	20/02/04
Revisione:	1.0
Nome Parte:	DRIVER PSL1000
Colore:	SL PSL1000DRV
Pagina:	2 di 3
Scale:	A3

Revised: Friday, February 20, 2004

Revision:

Item	Quantity	Reference	Part
1	2	C1, C8	CD100pF
2	7	C2, C3, C4, C5, C7, C9, C10	CD.1uF
3	1	C6	47/25
4	2	D7, D1	15V-1W
5	8	D2, D3, D4, D5, D6, D8, D9, D10	11DQ06
6	1	F1	BL02
7	3	JP1, JP2, JP3	molex 3.96
8	2	Q3, Q1	BC488
9	2	Q4, Q2	IRFD120
10	2	R1, R8	47R
11	4	R2, R3, R9, R10	4R7
12	2	R4, R11	1K
13	3	R5, R6, R12	10R
14	2	R7, R13	22R
15	2	T1, T2	PE-63385/T-GDRV
16	1	U1	TC427

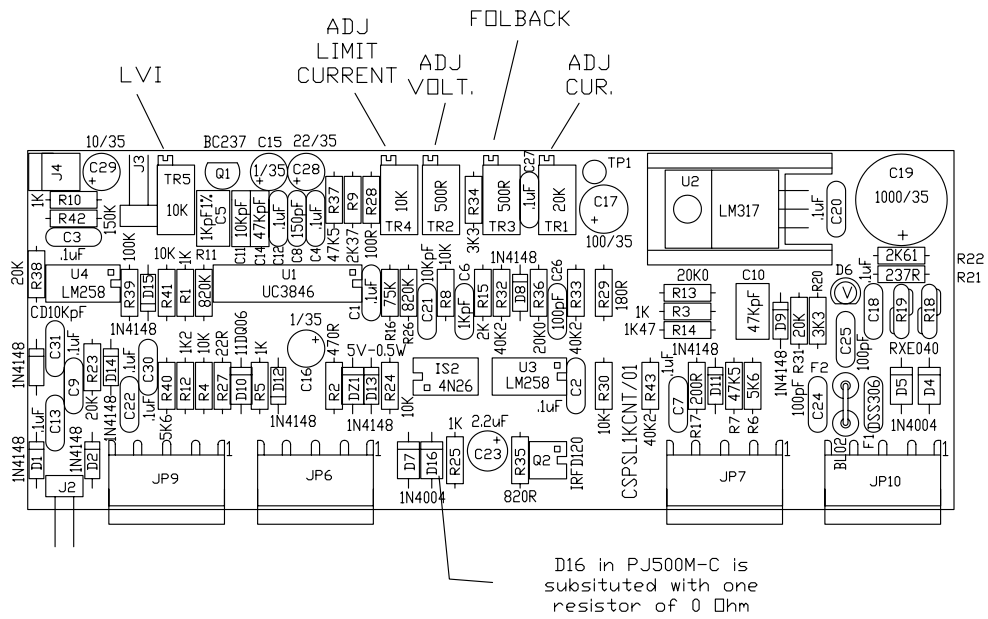

	NOME PROGETTO: PJ500M-C vers. LCD	NOME PARTE: PIANO DI MONTAGGIO SEZIONE CONTROLLO					
	AUTORE: U.T. - REV.: BERTI J.	DATA: 20/04/2003	REVISIONE: 1.0	SCALA: 1:1	SIZE: A4	PAGINA: 3 DI 3	
ARCHIVIAZIONE ELETTRONICA: "CARTELLA PROGETTI" SU "UT_SRV"	CODICE PROGETTO: /	CODICE DISEGNO: PSL1KCNT_01					
MATERIALE: /	TRATTAMENTO: /	PROFILO: /	STATO: <>				

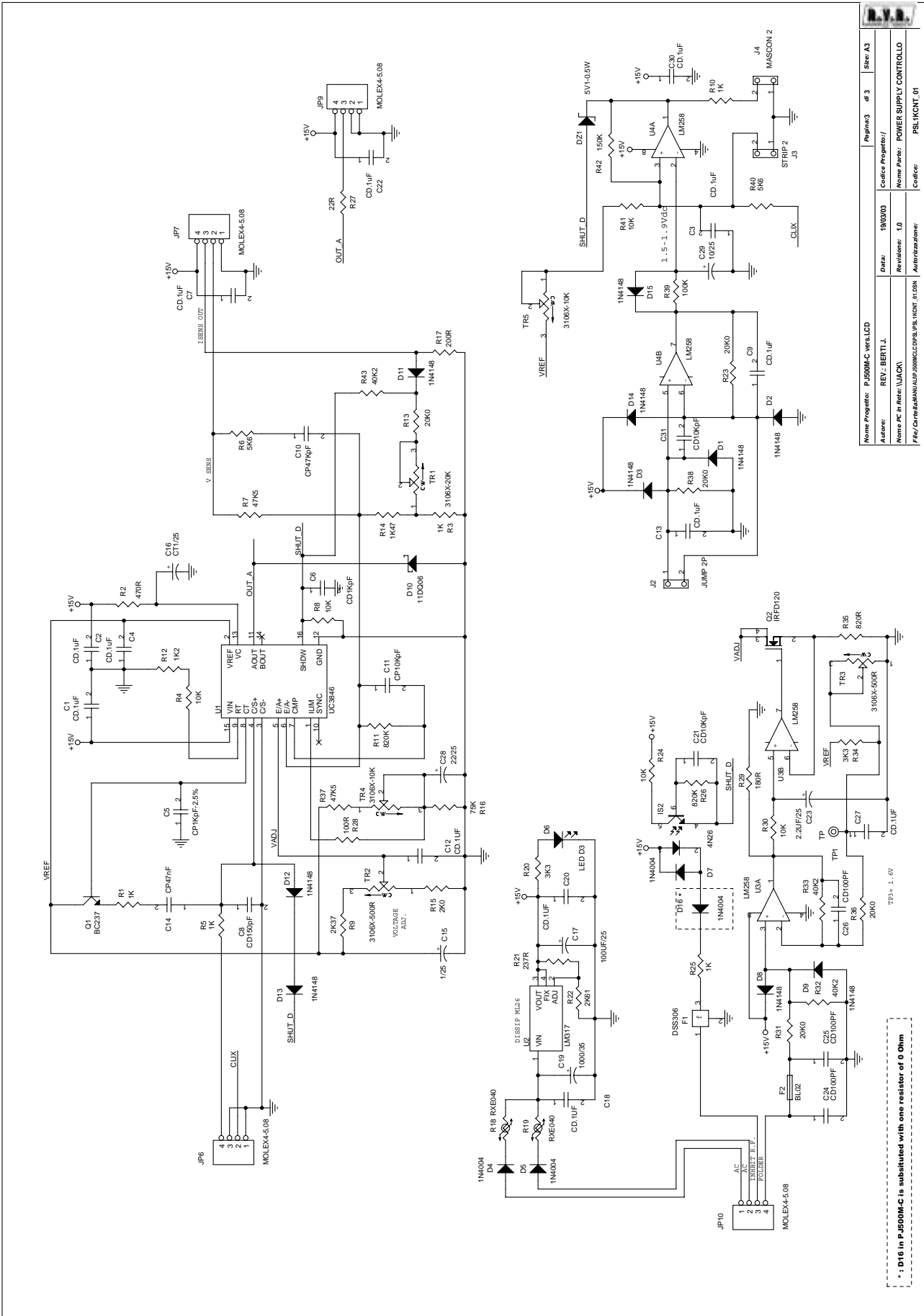

Nome Progetto:	PJ500M-C vers.LCD	Page:3	di 3	Scale:	A3
Autore:	REV: BERTU.J.	Circuito Progettato:			
Nome PC in Rete:	VAACK	Defini:	19/03/03	Nome Parte:	POWER SUPPLY CONTROLLO
File/Circuito/Schema/...	...	Revisione:	1.0	Autore/Incaricario:	PSLMONT 01

Revised: Friday, February 20, 2004

Revision:

Item	Quantity	Reference	Part
1	13	C1, C2, C3, C4, C7, C9, C12, C13, C18, C20, C22, C27, C30	CD.1UF
2	1	C5	CP1KpF-2.5%
3	1	C6	CD1KpF
4	1	C8	CD150pF
5	1	C10	CP47KpF
6	1	C11	CP10KpF
7	1	C14	CP47nF
8	1	C15	25-gen
9	1	C16	CT1/25
10	1	C17	100UF/25
11	1	C19	1000/35
12	2	C21, C31	CD10KpF
13	1	C23	2.2UF/25
14	3	C24, C25, C26	CD100PF
15	1	C28	22/25
16	1	C29	25-ott
17	1	DZ1	5V1-0.5W
18	10	D1, D2, D3, D8, D9, D11, D12, D13, D14, D15	1N4148
19	4	D4, D5, D7, D16	1N4004
20	1	D6	LED D3
21	1	D10	11DQ06
22	1	F1	DSS306
23	1	F2	BL02
24	1	IS2	4N26
25	4	JP6, JP7, JP9, JP10	MOLEX4-5.08
26	1	J2	JUMP 2P
27	1	J3	STRIP 2
28	1	J4	MASCON 2
29	1	Q1	BC237

Pagina lasciata intenzionalmente in bianco
This page was intentionally left blank