

SDC100

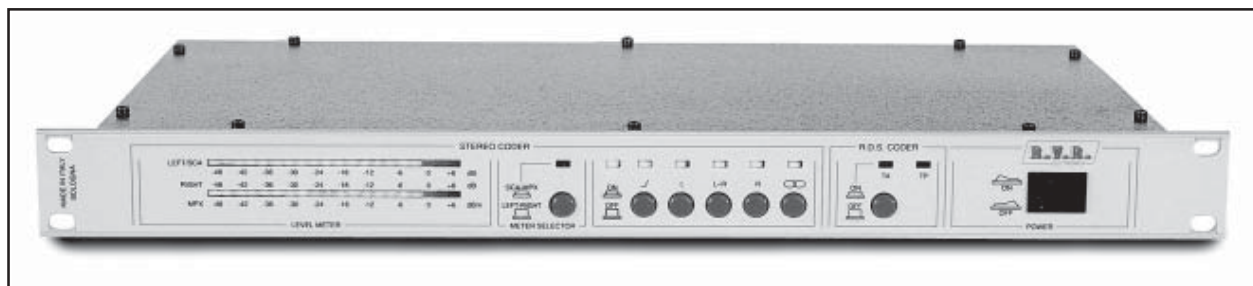

User Manual

Manufactured by  Italy



SDC100 - User Manual
Version 3.0

© Copyright 1993-2001
R.V.R. Elettronica SpA
Via del Fonditore 2/2c - 40138 - Bologna (Italia)
Telefono: +39 051 6010506
Fax: +39 051 6011104
Email: info@rvr.it
Web: www.rvr.it

All rights reserved

Printed and bound in Italy. No part of this manual may be reproduced, memorized or transmitted in any form or by any means, electronic or mechanic, including photocopying, recording or by any information storage and retrieval system, without the permission of the copyright owner.

Table of Contents

1. Preliminary Instructions	1
2. Warranty	3
3. First Aid	5
3.1 Treating electric shocks	5
3.2 Treating electric burns	6
4. General Description	7
5. Quick Start	9
5.1 Preparation	9
5.2 Installation	10
6 External Description	11
6.1 Front Panel	11
6.2 Rear Panel	12
6.3 Connectors Description	13
7. Technical Specifications	15
7.1 Mechanical Specifications	15
7.2 Electrical Specifications	15
8. Identification and Access to the Modules	17
8.1 Modules Identification	17
8.2 Theory of Operation	18
8.3 Mother Board	19
8.4 Power Supply Card	20
8.5 Panel Card	20
8.6 Stereo Coder Card	20
8.7 R.D.S. Card (optional)	20
9. Software Description	23
9.1 Software Installation (only with R.D.S. option)	23
Appendix	
Component layouts, schematics, bills of material	

This page was intentionally left blank

1. Preliminary Instructions

This manual is designed to provide a general guide to skilled and qualified personnel, who are aware of the dangers that may arise when handling electric and electronic circuits.

It does not aim to provide a complete description of all the safety precautions that must be observed by people who use this or similar equipment.

The installation, operation, maintenance and use of this piece of equipment involve risks both for people and the equipment itself, which must be handled only by experienced technicians.

R.V.R. Elettronica SpA does not assume responsibility for injuries to persons or damage to items caused by improper use or incorrect usage procedures, whether the users are experienced or not.

Users should observe local regulations and fire-prevention rules while installing and using this equipment.



WARNING: always disconnect the power before opening covers or removing any part of the equipment.

Take appropriate earthing measures to discharge the condensers and high voltage points before doing any maintenance work.



WARNING: this equipment may radiate radio-frequency energy, and if it is not installed according to the instructions, may cause troublesome interference to radio communications.

Operating this equipment in a residential environment may give rise to radio disturbance; if so, the user may be asked to take appropriate counter measures.

R.V.R. Elettronica SpA reserves the right to make modifications to the design and technical specifications of the equipment, and to update this manual without notice.

This page was intentionally left blank

2. Warranty

The guarantee, which is for 12 (twelve) months, is valid for any R.V.R. Elettronica product.

On components such as tubes for final amplifiers, the manufacturer's guarantee applies.

R.V.R. Elettronica extends all transferable original guarantees to its own products. To ensure that servicing is carried out properly and as fast as possible, the work shall be handled by R.V.R. Elettronica; any claims should be sent directly to R.V.R. Elettronica, in accordance with the defined procedures.

The warranty does not include:

- 1 damage while the equipment is being shipped to R.V.R. for repairs;
- 2 any unauthorized modification or repair;
- 3 accidental damage, or damage not due to defects in the equipment;
- 4 nominal damage not accidental;
- 5 shipping the equipment and insuring it, and replacement of parts or units.

Any damage to the equipment caused during shipment must be reported to the transporters and notified in writing on the forwarding receipt.

Any difference or damage discovered after delivery must be reported to R.V.R. Elettronica within 5 (five) days from the delivery date.

To take advantage of the guarantee, adopt the following procedure:

- 1 Contact the retailer or dealer where you bought the equipment; describe the problem or fault to check if there is a simple solution.

Retailers and Distributors can provide full information on the problems that occur most frequently; they can normally repair the equipment much faster than the manufacturer

- 2 If your dealer cannot help you, contact R.V.R. Elettronica and describe the problem to them; if necessary, you will be sent authorization with the necessary instructions;
- 3 When you have received authorisation, return the equipment carriage paid to the address specified.

Pack it carefully, if possible in the original packing, and seal the package.



Do not return the machine without prior authorization, otherwise it may be returned to you

- 4 Quote the machine's type, model and serial number; attach a written technical diagnosis listing all the problems and faults encountered, and enclose a copy of the invoice.

Replacement of parts under guarantee or spare parts can be ordered from the following address:



R.V.R. Elettronica SpA
Via del Fonditore, 2/2c
40138 BOLOGNA
ITALY
Tel. +39 051 6010506

quoting type, model and serial number of the device.

3. First Aid

Personnel involved in the installation, use, and maintenance of the equipment must be familiar with the theory and practice of first aid.

3.1 Treating electric shocks

3.1.1 If the victim is unconscious

Follow the first aid principles described below.

- Lay the victim down on his back on a rigid surface
- Free the respiratory tracts by raising the neck and pushing the forehead back (Figure 1).
- If necessary, check the breathing of the victim opening his mouth.
- If the victim is not breathing, start artificial respiration immediately (Figure 2): incline the head, close the nostrils, apply your mouth to the victim's and make four fast respirations.

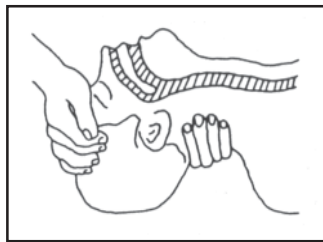

Figure 1



Figure 2

- Check the heart beat (Figure 3); if there is none, start a cardiac massage immediately (Figure 4) pressing the sternum approximately at the centre of the chest (Figure 5).

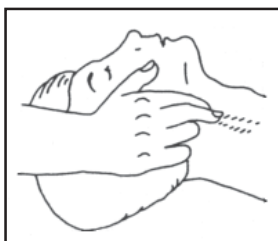

Figure 3

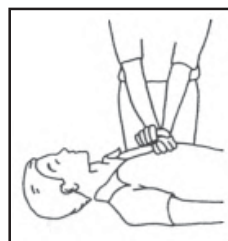

Figure 4

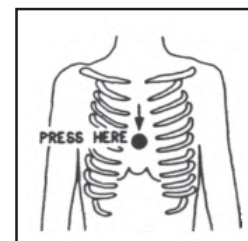

Figure 5

- If there is just one person providing first aid, he must adopt a rhythm of 15 compressions and 2 fast respirations alternately.
- If there are two persons, the rhythm must be 1 respiration and 5 compressions alternately

- Do not interrupt the cardiac massage during the artificial respiration.
- Call a doctor as soon as possible

3.1.2 If the victim is conscious

- Cover the victim with a blanket
- Keep him calm.
- Loosen the victim's clothes and keep him lying down
- Call a doctor as soon as possible

3.2 Treating electric burns

3.2.1 Large-scale burns and serious cuts

- Cover the area concerned with a sheet or a clean cloth.
- Do not break the blisters; remove any fabric and parts of clothing that may be attached to the skin; apply a suitable ointment.
- Treat the victim depending on the type of accident.
- Take the victim to hospital as soon as possible.
- If the arms and legs are injured, keep them raised.

If no medical help is available within an hour and the victim is conscious and has not retched, administer a liquid solution of salt and bicarbonate of soda: 1 teaspoonful of salt to every 250ml of water.

Get the victim to slowly drink half a glass of the solution, four times, over a period of 15 minutes.

Stop the treatment if the victim starts to retch.



Do not administer alcoholics!

3.2.2 Less serious burns

- Apply cold gauze compresses (not iced) using a clean cloth (i.e. as clean as possible).
- Do not break any blisters; remove any fabric and parts of clothing that may be attached to the skin; apply a suitable ointment.
- If necessary, dress the victim in clean dry clothes.
- Treat the victim depending on the type of accident.
- Take the victim to hospital as soon as possible.
- If the arms and legs are injured, keep them raised.

4. General Description

The SDC100 is a stereo digital coder. It is engineered for high performance stereo FM broadcasting, and it's contained in a 19" rack mountable 1HE case.

This device integrates in a cheap model, without quality compromises, all the technical characteristics of more expensive coders.

Moreover, there is a commands section with relative led indicators composed of: a preemphasis command switch, a left channel switch, a command to put in phase left and right channels, a right channel switch, and a 19 KHz tone selector.

On the rear panel there are: the voltage changer and the mains voltage socket, the plugs for 24Vdc external supply, a 19KHz pilot tone output connector with its phase regulator, a MPX1 output connector with its level selector, a MPX2 output connector with its level selector a SCA2/RDS input connector with its level selector, a SCA1 input connector with its level selector, a LEFT input connector with its level selector and a RIGHT input connector with its level selector.

This Stereo Coder uses a frequency synthesized internal digital circuitry that allows very linear modulation, high stereo separation, high input level capability.

The input/output analog section of good quality integrates oneself with digital system answering for high input dynamics, high signal/noise rate and very low distortion.

The SDC100 is designed in a modular way: the different functionalities are performed by modules that are then interconnected either directly (the male connector of one module plugs in the the female connector of another one) or by means of connectors-ended cables. This design allows easy servicing and replacement of the single modules.

This page was intentionally left blank

5. Quick Start

This chapter gives a concise view of the points that are necessary for the installation of the device. If any item is not completely clear, for example when you use the exciter for the first time, we strongly suggest to read throughly the manual.

5.1 Preparation

Unpack the coder and before any other operation check the unit for any shipping damage and check that all the controls and connectors on the front and rear panels are in good conditions.

Check the mains voltage selector on the rear panel: the selected value is indicated by an arrow. If required, extract the selector block levering with a little screwdriver. Rotate the block until the correct printed value corresponds with the arrow, then reinsert it.

The voltage selector block also contains the line fuse. The kind of the adapter fuse is:

A.C. LINE FUSE 1A 5X20

Verify that SDC100 coder is switch off.

Connect the output connector of the mixer or of the last receiver to “Right” and “Left” input connector. The SDC100 is balanced and can be of “XLR” type or socket type.

Respect the XLR connectors pins position showed in the chapter 6. SDC100 has SCA and RDS inputs; the technical characteristics of these inputs are mentioned in chapter 7.



NOTE: It's important don't connect any audio signals not codified because will be mixed with MPX signal on the MPX output.

Connect the mains cable to the plug on the rear of the coder.



NOTE: This device shall be correctly connected to ground. Correct grounding is essential both for safety and to reach the rated performances.

5.2 Installation

The SDC100 coder is factory-adjusted to obtain the maximum stereo separation using professional instrumentation. This setting is normally the best one for most FM stations.

However, possible FM transmitter phase delays can be compensated adjusting the pilot tone phase, to obtain the maximum stereo separation performance for each transmitting system.



NOTE: Please note that this kind of operations should only be done by skilled technical people. Remember that this operation is not normally needed. Opening the device may void your warranty.

To obtain a precise adjustment, it's necessary to use a professional measurement stereo decoder.

If such a stereo decoder is not available, an approximative adjustment can be executed in the following way:

- Put into "Left" and "Right" inputs of the coder a 1KHz sinusoidal signal.
- Switch off the preemphasis command.
- Adjust input level to read on the led meter a signal of 0 dBm (yellow LED).
- Adjust output level for a level that entails a deviation of 75KHz (100%) on the transmitter meter.
- Connect an oscilloscope to low frequency output of the left channel of a good quality tuner.
- Switch off the left channel on the coder and adjust the pilot phase on the stereo coder card (C19) to obtain on the oscilloscope the minimum signal residual.
- Now, connect the oscilloscope on low frequency output of the tuner right channel and disconnect coder right channel inserting again left channel.
- Adjust again the phase to obtain a minimum residual of signal.
- Repeat to the bitter end the operations the last 4 points until to obtain maximum symmetrical separation.

Now the coder is perfectly interfaced to your FM transmitting system.



NOTE: Even if the tuner used for the adjustments can be of good quality, the stereo separation of commercial equipment cannot normally be as good as the ones of professional transmitting systems. For this reason, the results measured with this procedure will not quantitatively reflect the characteristics of the SDC100.

6 External Description

This chapter describes the elements of the front and rear panels of the SDC100.

6.1 Front Panel

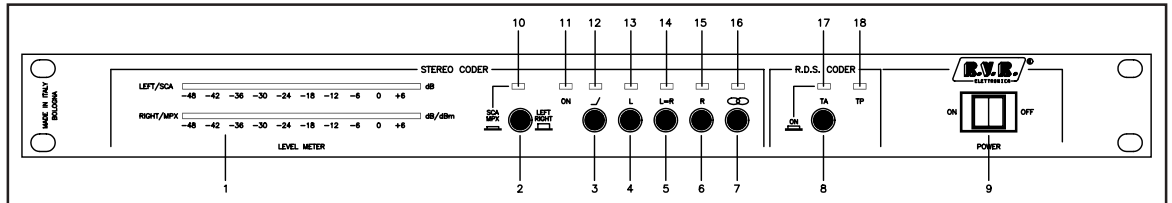

figure 6.1

[1] LEVEL METER	"Left" and "Right" channels LED bar meters
[2] METER SELECTOR	Selector for meter (SCA/MPX or LEFT/RIGHT)
[3] PRE-EMPHASIS	Pre-emphasis ON/OFF selector
[4] L	Left channel ON/OFF selector
[5] L=R / L=-R	Channel phase selector
[6] R	Right channel ON/OFF selector
[7] 19 KHz	19 KHz pilot tone selector
[8] TA	TA selector - (used only with RDS card)
[9] POWER	ON/OFF power switch
[10] METER SELECTOR LED	LED ON - SCA/MPX meter selector LED OFF - LEFT/RIGHT meter selector
[11] ON LED	Power ON LED
[12] PRE-EMPHASIS LED	Pre-emphasis ON/OFF LED indicator
[13] L CHANNEL LED	Left channel ON/OFF led indicator
[14] L=R LED	Channels phase LED indicator
[15] R CHANNEL LED	Right channel ON/OFF LED indicator
[16] 19 KHz LED	19 KHz tone LED indicator
[17] TA LED	TA LED - (used only with RDS card)
[18] TP LED	TP LED - (used only with RDS card)

6.2 Rear Panel

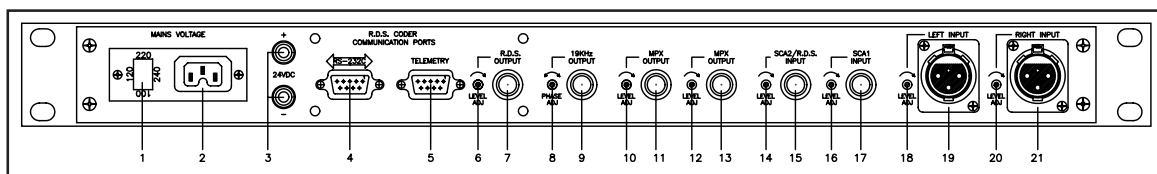

figure 6.2

- | | |
|--------------------------------------|---|
| [1] VOLTAGE CHANGER & A.C. LINE FUSE | Fuse block and line voltage selector. Use a small screwdriver to change the fuse or line voltage. Rotate the block and position it for the desired voltage. |
| [2] MAINS VOLTAGE | A.C. power line socket |
| [3] 24VDC | Plug for the external 24Vdc supply |
| [4] RS-232C | DB9 connector for direct or modem serial communication (only with RDS card) |
| [5] TELEMETRY | Telemetry DB9 connector of optiona board (only with RDS card) |
| [6] R.D.S. LEVEL ADJ | Trimmer for phase adjustments (only with RDS card) |
| [7] R.D.S.OUTPUT | RDS output connector, BNC type |
| [8] PHASE ADJ | Trimmer for phase adjustments (not present) |
| [9] 19KHz OUTPUT | 19KHz output connector, BNC type |
| [10] MPX1 OUT LEVEL ADJ | Trimmer for MPX1 output level adjustment |
| [11] MPX1 OUTPUT | MPX1 output connector, BNC type |
| [12] MPX2 OUT LEVEL ADJ | Trimmer for MPX2 output level adjustment |
| [13] MPX2 OUTPUT | MPX2 output connector, BNC type |
| [14] SCA/RDS LEVEL ADJ | Trimmer for SCA2/RDS input level adjustment |
| [15] SCA2/RDS INPUT | SCA2/RDS input connector, BNC type |
| [16] SCA1 LEVEL ADJ | Trimmer for SCA1 input level adjustment |
| [17] SCA1 INPUT | SCA1 input connector, BNC type |
| [18] LEFT LEVEL ADJ | Trimmer for left input level adjustment |
| [19] LEFT INPUT | Left input connector, XLR female type |
| [20] RIGHT LEVEL ADJ | Trimmer for right input level adjustment |
| [21] RIGHT INPUT | Right input connector, XLR female type |

6.3 Connectors Description

6.3.1 RS 232 (only with RDS card)

Tipo: DB9 female

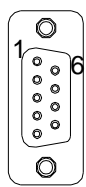

1	NC
2	TX_D
3	RX_D
4	NC
5	GND
6	+12V
7	NC
8	CTS
9	NC

Note: Normally, the SDC100 is configured as DCE (Data Communication Equipment) for serial communication.

6.3.2 Telemetry (only with RDS card)

Type: DB9 female

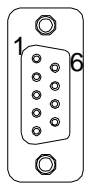

1	Reserved for future use
2	Reserved for future use
3	Reserved for future use
4	Reserved for future use
5	Reserved for future use
6	Reserved for future use
7	Reserved for future use
8	Reserved for future use
9	Reserved for future use

6.3.3 Left (MONO) / Right (MPX Bal)

Type: XLR female



1	GND
2	Inphase (+)
3	Return (-)

This page was intentionally left blank

7. Technical Specifications

7.1 Mechanical Specifications

Panel size	483 mm (19") x 44 mm (1.7") (1 HE)
Depth	242 mm (9.5")
Weight	4 Kg
Temperature range	-10 °C ÷ +50 °C

7.2 Electrical Specifications

General

A.C. SUPPLY	100-130 V, 50-60 Hz 198-250 V, 50-60 Hz
D.C. SUPPLY	24V

Audio Input (L & R)

Input level	Adjustable from -12 to +15 dBm
Input sensivity	194mVrms (-12dBm)
Input impedance	50 Ohm / 600 Ohm / 10KOhm (internally selectable)
Input connector	XLR type, female
Frequency rresponce	< ±0.3dBm from 20KHz to 15KHz
CMRR	> 60 dB
19KHz suppression	> -50dB
38KHz suppression	> -80dB
Pre-emphasis	OFF / 25µS / 50µS / 75µS (internally selectable)

SCA Input

Input level	Adj. from 0 to +15dBm for -20dB output
Input impedance	> 10KOhm (unbalanced)
Input connector	BNC type
Frequency response	< ±0.2dB from 50KHz to 100KHz

RDS Input

Input level	Adj. from 0 to +15dBm for -20dB output
Input impedance	> 10KOhm (unbalanced)
Input connector	BNC type
Frequency response	< ±0.2dB from 50KHz to 100KHz

Stereo Generator

Pilot tone frequency	19 KHz ±0.1
Pilot tone level	-20dB (internally adjustable)
Pilot tone output connector	BNC type, 1Vpp
MPX output	2, completly independent
MPX output connector	BNC type
Output 1 impedance (multiplex)	50 Ohm (unbalanced)
Output 1 level (multiplex)	adjustable from -10 to +10 dBm
Output 2 impedance (multiplex)	50 Ohm (unbalanced)
Output 2 level (multiplex)	adjustable from -10 to +10 dBm

Separation (50 Ohm output load)	45dB from 30Hz to 400Hz 55dB from 400Hz to 5KHz 65dB from 5KHz to 10KHz 60dB from 10KHz to 15KHz
Separation (600 Ohm output load)	50dB from 30Hz to 400Hz 60dB from 400Hz to 10KHz 57dB from 10KHz to 15KHz
Separation (10KOhm output load)	70dB from 30Hz to 5KHz 60dB from 5KHz to 10KHz 56dB from 10KHz to 15KHz
Subcarrier suppression (38KHz)	> 70 dB
THD (1KHz, output = +12 dBm)	< 0.03%
Signal / Noise ratio	-80 dB (DIN AUDIO), decoded, de-emphasized left and right RMS
Power requirements	100-130Vac, 50-60Hz 198-250Vac, 50-60Hz
DC power requirements	24V, 500mA max

RDS Output (only with RDS card)

RDS Signal	as in CENELEC EN 50067 specs
Codification	Differential at two levels
Modulation	DSB with suppressed carrier
Frequency	57 KHz
Range	±2.4 KHz
RDS output level	20-1000 mVpp
Output impedance	100 Ohm
RDS user messages	16 words of 8 characters, whose 2 with data and transmission time
Alternative frequencies	25
Message change	with IBM-compatible PC
Data preservation	10 years (in absence of power supply)
Connection	RS232-C standard
Comunication	Full Duplex
Velocity	1200 baud
RS232-C connector	9 Pin Cannon Female
Message management	checked with a microchecker
Telemetry connector	9 Pin Cannon Female

8. Identification and Access to the Modules

8.1 Modules Identification

Figure 8.1 shows the upper view of the internal of the coder. SDC100 is composed of different modules wired between them with connectors, allowing for easy servicing or module substitution.

Figure below shows the upper view of the device with the indication of the different components.

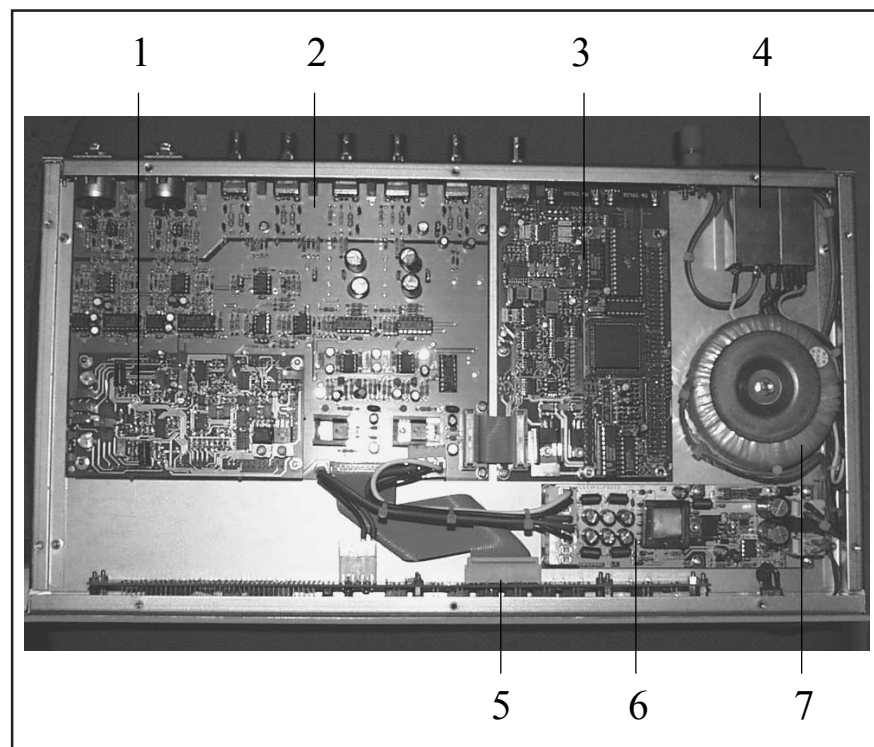

figure 8.1

- [1] Stereo coder card
- [2] Main card
- [3] R.D.S. card (optional)
- [4] Voltage changer and mains supply socket
- [5] Panel card
- [6] Power supply card
- [7] Transformer

8.2 Theory of Operation

The figure shows the block diagrams of SDC100. The blocks are described in the following chapter:

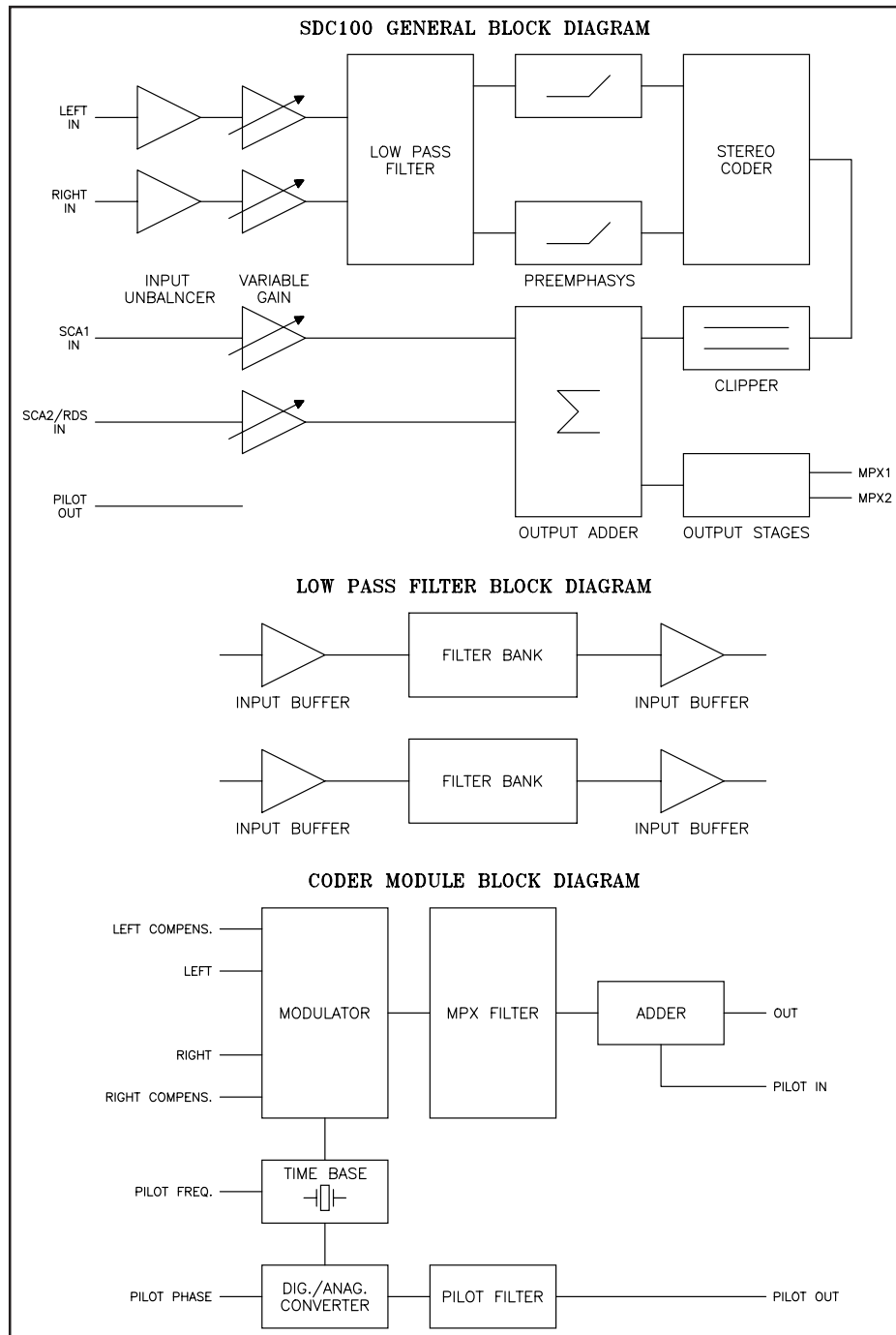

figure 8.2

8.3 Mother Board

This card receives input signals (LEFT, RIGHT, RDS and SCA), for example from a audio mixer or a satellite receiver. These signals are normalized (amplified or attenuated) for the nominal levels, filtered (15KHz filters are included for the L and R channels) and pre-emphasized.

Then, the signal is processed by a digital circuit and then is sent to MPX output. Here, this signal is mixed, if present, with RDS or SCA input.

On the board are presents same jumpers that allow to select the input impedance (10KOhm, 600Ohm, 50Ohm), to increase the SCA gain, to select the pre-emphasis value (25µS, 50µS, 75µS or without) and than to insert the clipper circuit.

See the figure below for the jumper setting:

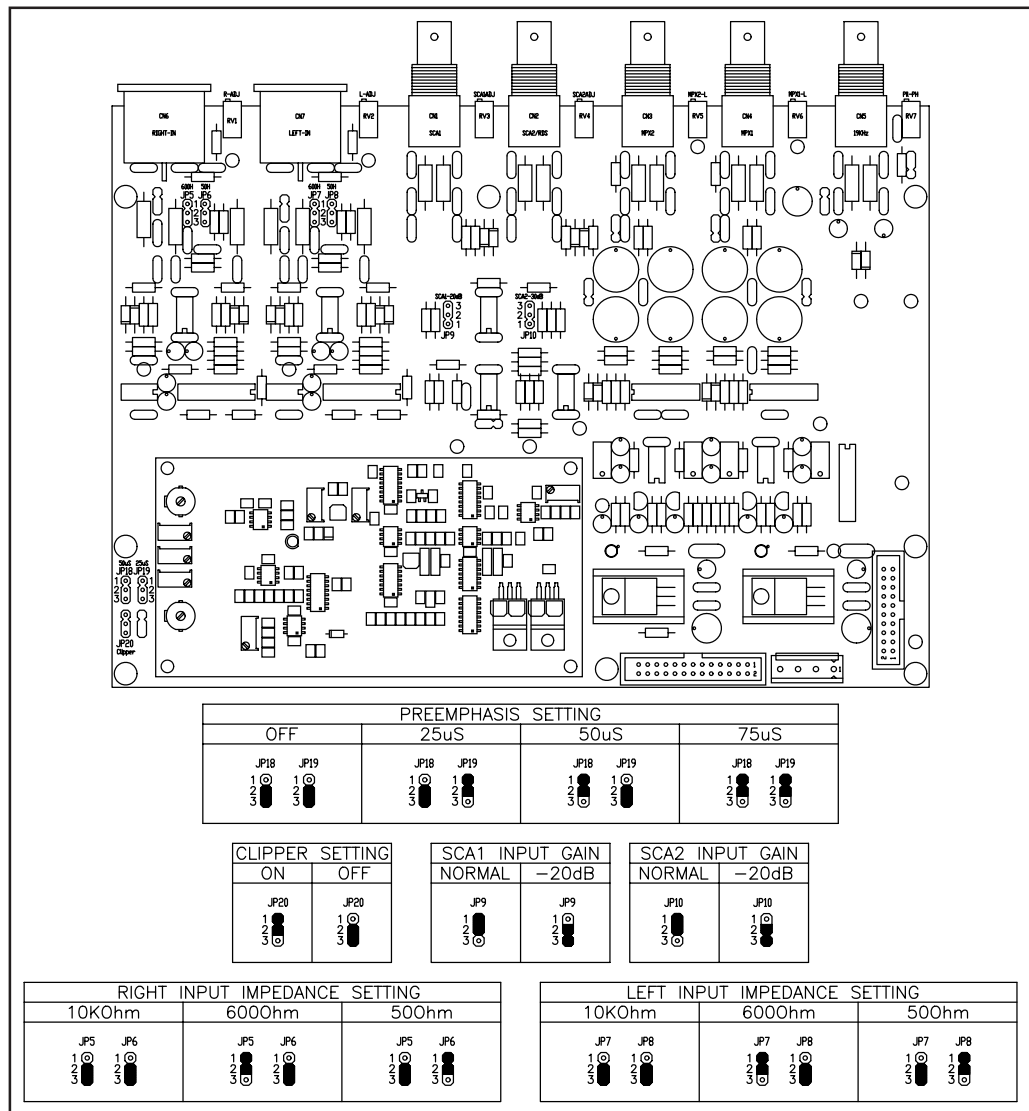

figure 8.3

8.4 Power Supply Card

The switching power supply drives the main card and panel card. This power supply operates automatically the exchange between main power supply and external power supply at 24Vdc.

8.5 Panel Card

This card is fixed on the front panel. The panel card allows to display the Left/Right and SCA/MPX signals level through a level meter on a scale from -48 dB to +6 dB for the Left/Right/SCA signals and a scale from -48 dBm to +6 dBm for MPX signal.

The standard adjusting level for the Left and Right channels is 0 dB (yellow LED ON).

8.6 Stereo Coder Card

The stereo coder card is fixed on the main card and is subdivided in two sections: filtering and coding.

This card, that is the most important card of the SDC100, provides to elaborate the signals coming from the main card and to transform them in stereo signal.

8.7 R.D.S. Card (optional)

The R.D.S. card allows to transmit, with the radio signal (mono or stereo), a data channel as specified in the paper "Specification of the radio data system (RDS)", which is issued by the European Committee for Electrotechnical Standardization (CENELEC) Ref. N° EN 50067.

The purpose of this card is to manage some of the principal services defined by the standard CENELEC EN 50067 as: TP, TA.

As follows, we'll mention a short description about the function of each of these services.

TP - TRAFFIC PROGRAM IDENTIFICATION: this service indicates with a signal on the receiver display that the program we're receiving includes traffic news.

TA - TRAFFIC-ANNOUNCEMENT IDENTIFICATION: it's used to indicate to the car-driver that the traffic news are on air. The receiver could use the signal in one of the following modes:

- a) To switch automatically from the Tape (or from the Compact Disk) to the radio;
- b) To automatically switch on the radio when the traffic news begin;

c) To automatically change over from a station which doesn't transmit traffic news.

The R.D.S. is proper for the transmission of information in mono/stereo programs of VHF/MF (87.5-108 Mhz).

It satisfies the requested requirements to the transmission of supplementary data on radio programs:

- 1) Compatibility with the current mono/stereo transmissions;
- 2) Absence of interferences towards the adjacent programs;
- 3) Compatibility with other identification systems which are already working.

The system, selected by an international specialistic team, allows the data transmission at a speed of 1187.5 bit/sec with phase modulation at two levels , carrier wave 57 MHz and range ± 2 KHz.

This board implements the synchronization with the pilot tone and the generation of the modulated subcarrier, using the data provided by the CPU card.

8.7.1 CPU Card

The CPU card is fixed to the R.D.S. board.

This board generates the bit stream that is transmitted on the RDS channel. It is programmed externally via the serial interface.

The main characteristics of the CPU board are:

- Microprocessor: 80C552
- Eprom size: 64KBytes
- Static RAM size: 32KBytes
- Communication interfaces: RS232-RS485 and I²C Bus
- Self-diagnosys Leds: 9, red

This page was intentionally left blank

9. Software Description

9.1 Software Installation (only with R.D.S. option)

The supplied software (the same for all the devices R.D.S. of the R.V.R. Elettronica S.P.A.) has been planned in wise to simplify the use also by unpractised user; every performance is complete with a different available options list in order to reduce the difficult on setting.

In case of, for any reason, on the screen are nonsense indications or the PC jams, we recommend to reset it and to repeat the procedure from the beginning.

The supplied software forecasts either the alphanumerical commands use or the following ones:

TAB [] to go from a window to another one of the same screen;

UP/DOWN DIRECTIONAL ARROWS to run the different voices of an internal list at one frequency or to go from a word to another one of a message or to change place on the screen commands (ex. ABORT, CONFIRMATION, MODIFY);

<ENTER> to select the desired function;

DEL to cancel some message characters and/or cody;

LEFT/RIGHT DIRECTIONAL ARROWS to change place into a message word.

The firm R.V.R ELETTRONICA Spa supplies in kit a 3.5" DOS disk containing the program which allows the total management of messages and ENCODER services.

For that it's necessary an IBM compatible Personal Computer with RS232 serial line and a 3.5" disk drive.

The management could be realized also during the SDC100 working on following this procedure:

- 1) Connect the serial cable between the PC and the 9 pins connector placed on the front panel (REMOTE);
- 2) Connect the PC to the power supply net;
- 3) Switch on the PC and the stereo coder with optional R.D.S. board;
- 4) When the prompt appears on the screen (normally C:\), insert the supplied disk (after made a copy) in the proper drive;

- 5) Finger A: or B: (it depends from the disk drive type);
- 6) Entry in the program directory on operating as follows:
 - a) finger CD ENGLISH <INVIO> (program in italian language);
 - b) finger RDS <INVIO> (to start the management program);
- 7) On the screen you can see the followings presentation window:

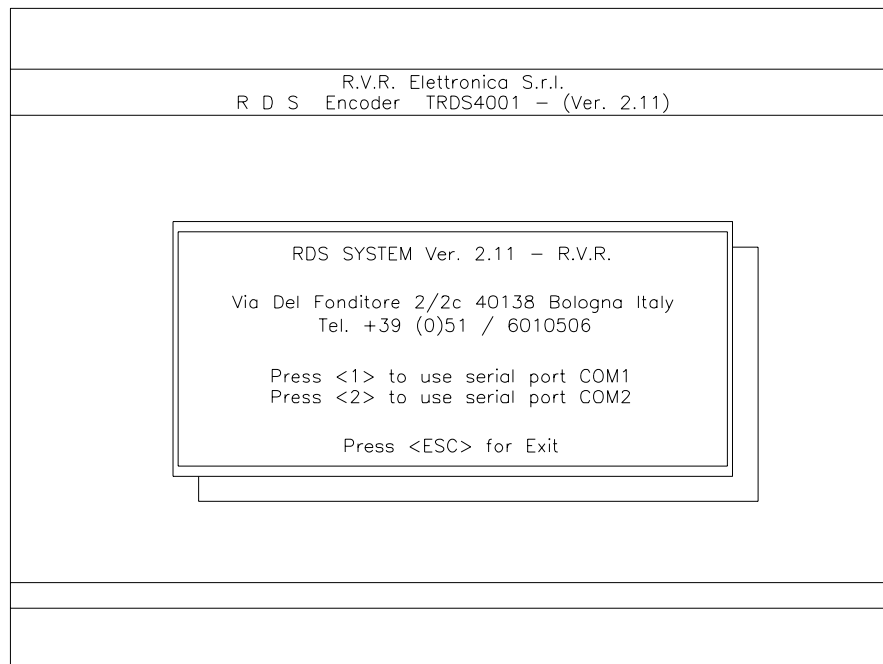

- 8) In this window we recommend to finger:

1 to use serial port COM1

2 to use serial poert COM2

ESC for EXIT

It's necessary to finger the serial line number used for the ENCODER connection, 1 for COM1 and 2 for COM2.

After indicating the serial line the program trys to connect with the system.

If the connection does not working within 5 seconds, the help instructions appear on the screen.

If all is right, the chief menu appears, which shows as follows:

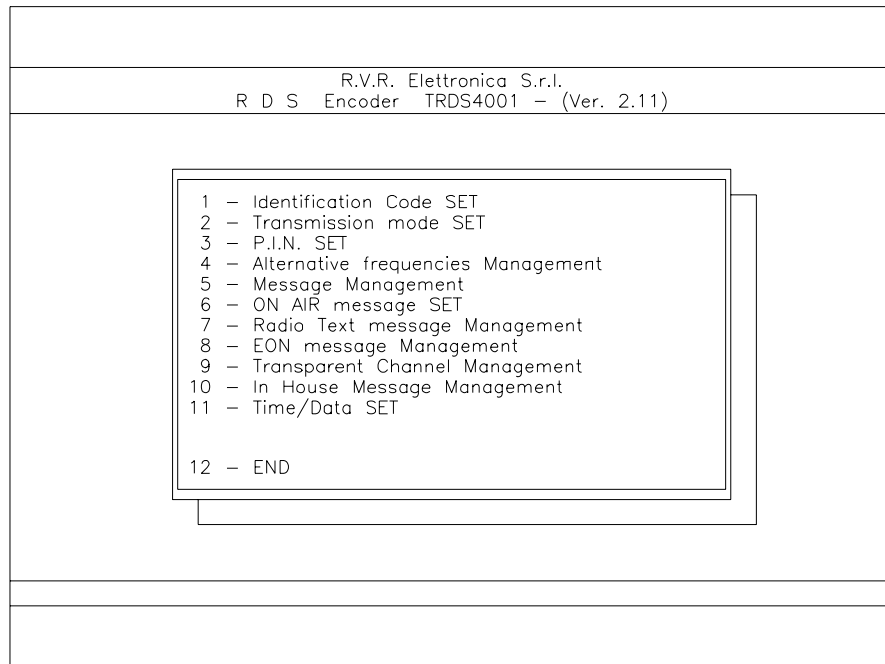

N.B. In the up-link sat encoders, before the chief menu, select the place (or the encoder) you desire to connect to.

A) MAIN MENU

The main menu allows the following functions:

- 1) Identification code SET
- 2) Transmission mode SET
- 3) P.I.N. SET
- 4) Alternative frequencies Management
- 5) Messages Management
- 6) ON AIR message SET
- 7) Radio Text message Management
- 8) EON messages Management
- 9) Transparent Channel Management
- 10) In House Message Management
- 11) Time/Data SET
- 12) End

B) IDENTIFICATION CODE SETTING

It's used to set or change the identification code of a broadcaster (PROGRAM IDENTIFICATION CODE - PI) which has to be univocal into the broadcaster covering area. It's depends from the country of the braodcaster and from the same broadcaster covering areas. The menu shows as follows:

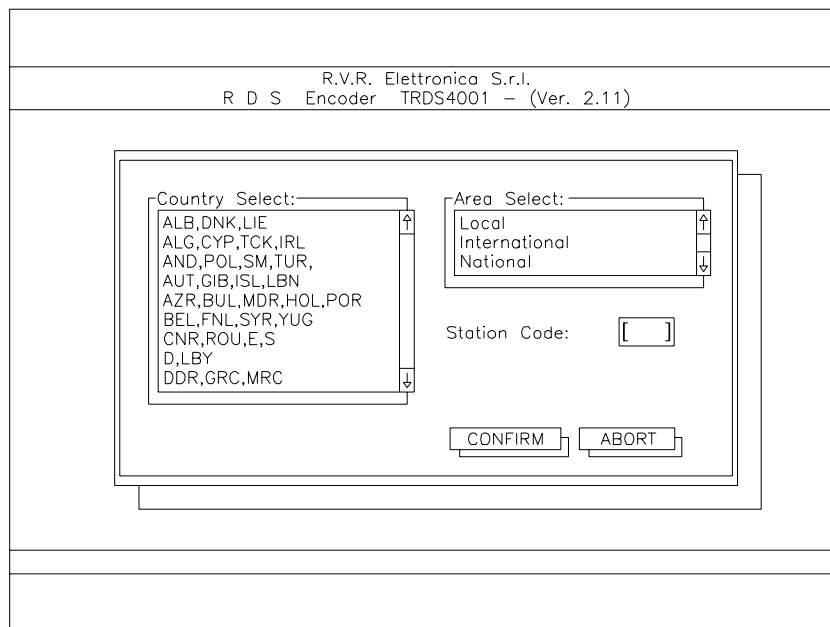

R.V.R. Elettronica S.r.l.
R D S Encoder TRDS4001 - (Ver. 2.11)

Country Select:

- ALB, DNK, LIE
- ALG, CYP, TCK, IRL
- AND, POL, SM, TUR,
- AUT, GIB, ISL, LBN
- AZR, BUL, MDR, HOL, POR
- BEL, FNL, SYR, YUG
- CNR, ROU, E, S
- D, LBY
- DDR, GRC, MRC

Area Select:

- Local
- International
- National

Station Code: []

CONFIRM ABORT

For the planning it's necessary to select the country in the COUNTRY SELECT window (ex. ENTER command on I, JOR), to select the covering area on the window AREA SELCET (ex. RETURN command on LOCAL or NATIONAL) and the code (number from 1 to 255).

The on the encoder values and/or selected are pointed out on the screen in a different color strip.

The preselected data are revised on the encoder only pressing ENTER when the cursor is placed on the screen-command (lighted one) CONFIRM; they are neglected on pressing the screen-command ABORT.

Normally, these data are setted only for the first time.

C) TRANSMISSION MODE SET

It's used to set or change the by the broadcaster sended programmes type, the used transmission type and to allow the TP services (Traffic-Programmes Identification), TA (Traffic-Announcement Identification), M/S (Music/Speech Switch).

The setting menu shows as follows:

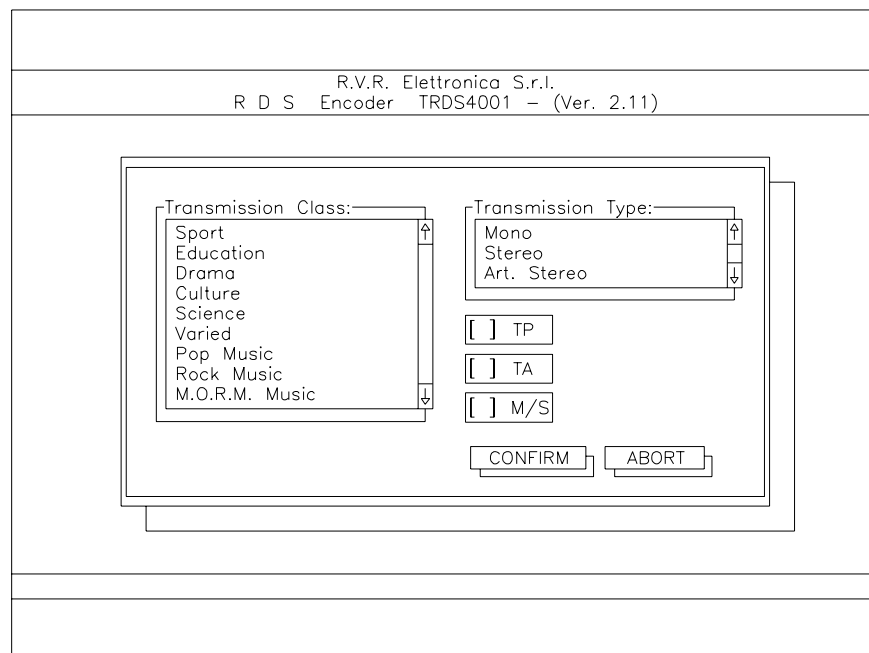

For the planning it's necessary to select the sended programmes type, in the TRANSMISSION CLASS window (ex. command ENTER on VARIOUS or NOTICES) and to select the transmission type used in the TRANSMISSION TYPE window (ex. command ENTER on STEREO).

The on the encoder values, and/or selected, appear on the screen in a different colour strip.

To allow the TA; TP; or M/S services, take place on the proper window and make them working on pressing the cursor: if a "X" lights in this window, the procedure is right.

The preselected data are revised on the encoder only on pressing the command ENTER when is lighting the CONFIRM screen-command; they are neglected on pressing the screen-commander ABORT.

Normally, these data are setted only for the first time.

D) P.I.N. SET - PIN

It's used to planning the receiver to receive specificated programmes in a preselected date and hour.

In oder to right operate, it's necessary to ability the service; for that, take place on the "P.I.N. On/Off" window and press the cursor; if a "X" lights in the window, the procedure is right.

Now, it' necessary to set the date, the hour and the minute of the service starting.

The preselected data are revised on the encoder only on pressin the command ENTER when is lighting the screen-command UPDATE; they are neglected on

pressing the ABORT screen-command.

The "P.I.N. SET" shows as follows:

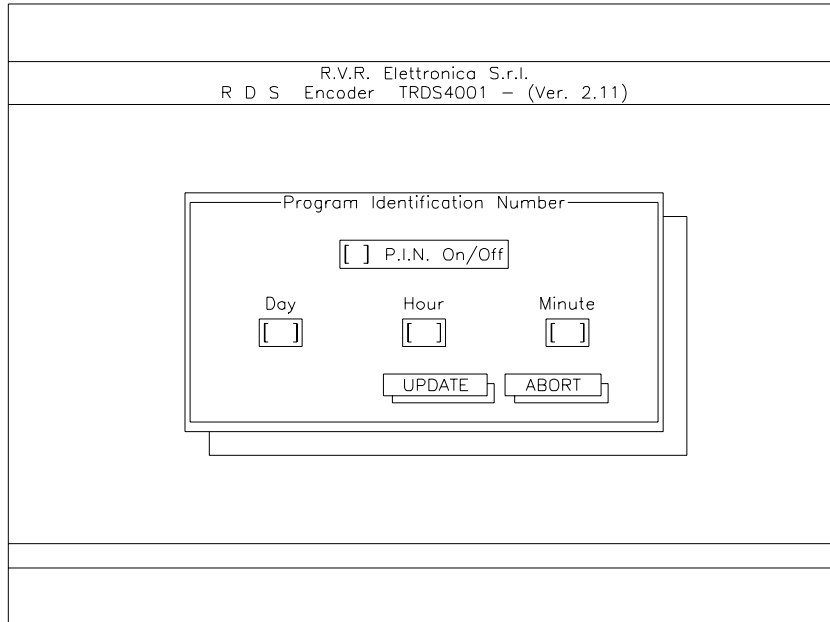

E) ALTERNATIVE FREQUENCIES MANAGEMENT - AF -

It's used to set or change the broadcaster sinthony frequencies lists in its diffusion areas.

The menu shows as follows:

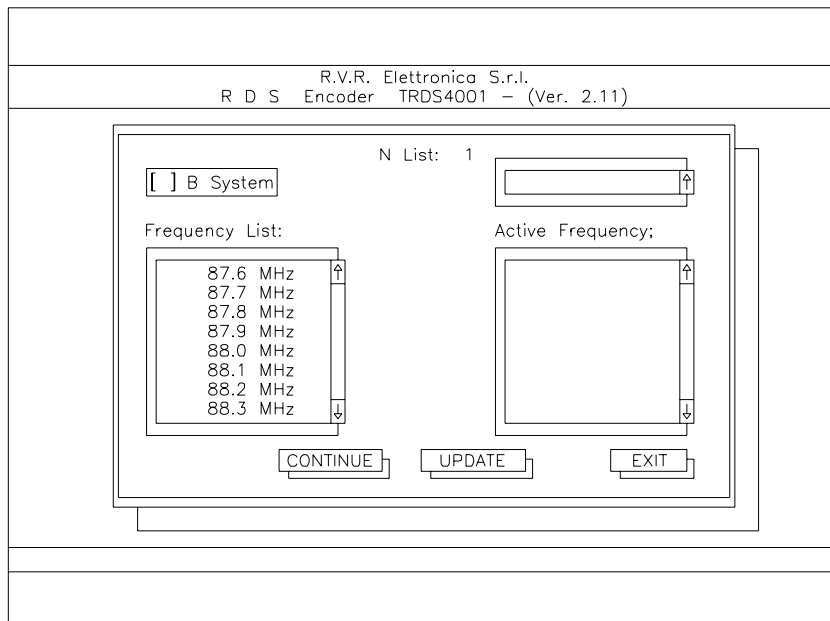

For the alternative frequencies transmission, the program uses two methods: A (default selected) and B.

The two methods use the following size:

A METHOD: every station send a nearly frequencies list, after the contained frequencies number (max. 25);

B METHOD: every station send a frequencies list for every transmitters which it gets.

The list begins with the chief frequency and it follows with the by transmitters used ones (max. 12 and nearby at the current user areas).

The method B is recommended when the frequencies list is long, as allows at autotuning the system to check a smaller frequencies number in order to more quickly search the new syntony frequency. At the contrary, if the frequencies number is small, the method A is recommended, as it allows a smaller data number transmission.

In order to set the method B, it's necessary to place the cursor on the window showing "METHOD B" and to press the spacebar; if a "X" appears, the procedure is right.

In addition to the "METHOD B", on the screen appear other two windows: FREQUENCY LIST and ACTIVE FREQUENCY, both of them containing a frequencies list. The submultiples of 100 khz are not admitted by the standard. On pressing ENTER on a into a FREQUENCY LIST frequency you select the one which is showed on the ACTIVE FREQUENCY window. If the setted frequency is already in the ACTIVE FREQUENCY list, the PC utters indicating the error.

On pressing ENTER on a frequency of the ACTIVE FREQUENCY list you cancel the same frequency.

The setted data are revised on the encoder only on pressing ENTER when the screen-command UPDATE is pointed out on the screen; they are neglected on pressing the screen-command EXIT.

Normally, these data are setted only for the first time.

F) MESSAGE MANAGEMENT

It's used to set or modify the user messages contains (max. 8) which are visualized on receivers equipped of RDS syntonized with the broadcaster.

Every message contains max 16 words of 8 characters and every words could be send and visualized on the receiver display for a time changing from 2 to 60 seconds.

On selecting the voice "MESSAGE MANAGEMENT" from the chief menu, it appears a submenu: the user has to choose which messages he wants to modify (or to simply visualize); the new menu shows as follows:

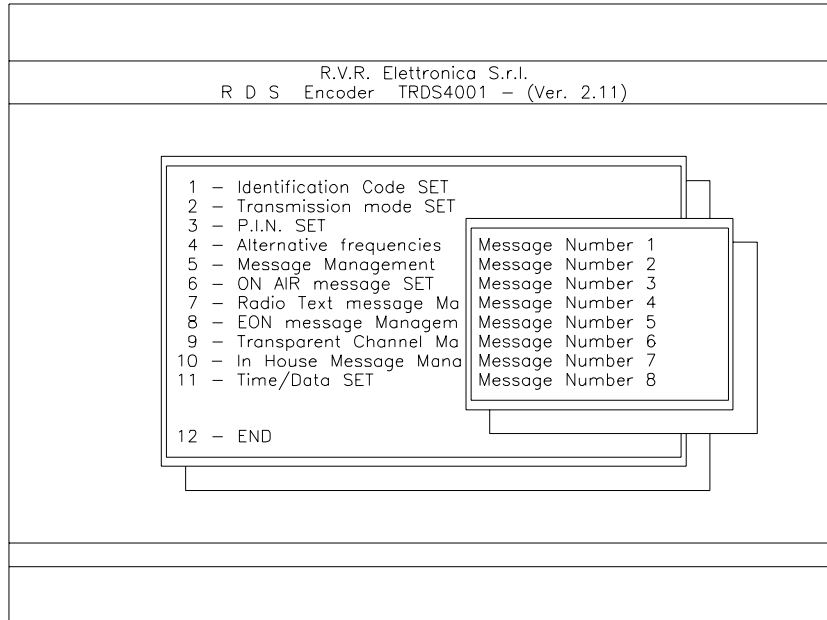

At this point, the user selects one of the 8 messages (ex. message number 1) and the current message contain appears.

The new menu is the following:

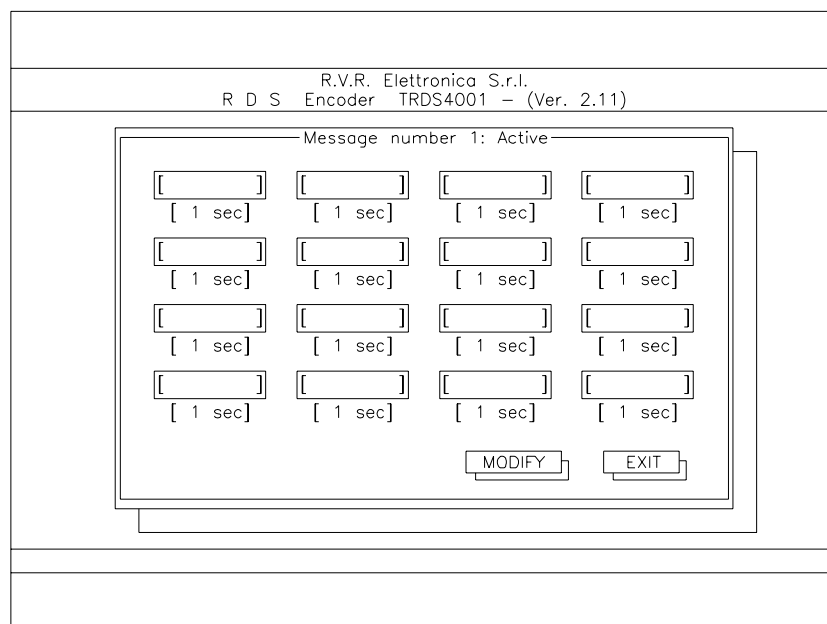

If the user desires to modify the text, than press ENTER on the screen command MODIFY or press RETURN on the screen command EXIT.

On selecting the window "MODIFY", the new menu appears, which are listed the selectable message types in; the new menu is the following:

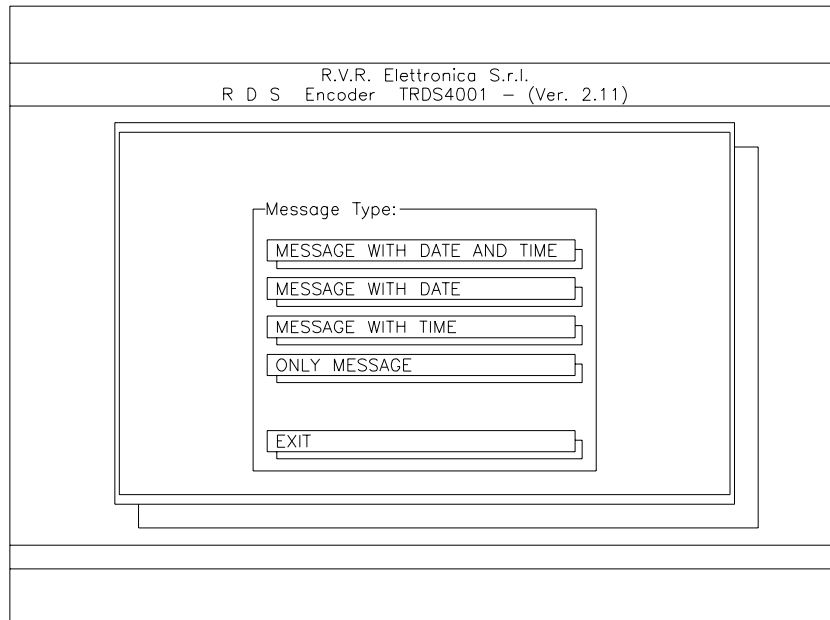

The possible type are four:

- a) Message with Date and Time;
- b) Message with Date;
- c) Message with Time;
- d) Only Message.

At this point it's possible to select the desired message type, or in case of the user does not desire any modifies, it's possible to go out from the menu on selecting the voice EXIT; the program returns at the chief menu.

The choices are possible on placing the cursor with the directional arrows "UP/DOWN" and on confirming with the command ENTER.

In case of the user has selected such a program, the new menu shows as follows:

R.V.R. Elettronica S.r.l.
 R D S Encoder TRDS4001 - (Ver. 2.11)

Message number 1: Active

[]	[]	[]	[]
[1 sec]	[1 sec]	[1 sec]	[1 sec]
[]	[]	[]	[]
[1 sec]	[1 sec]	[1 sec]	[1 sec]
[]	[]	[]	[]
[1 sec]	[1 sec]	[1 sec]	[1 sec]
[]	[]	[]	[]
[1 sec]	[1 sec]	[1 sec]	[1 sec]

In case of "MESSAGE with DATE and TIME", the message will contain as first 2 words, of the 16 ones, the date and the hour.

In case of "MESSAGE with DATE", the message will contain as first word, of the 16 ones, the data.

In case of "MESSAGE with TIME", the message will contain as first word, of the 16 ones, the HOUR.

In case of "ONLY MESSAGE", the 16 words are all reserved for the text message.

In order to take place into the message from a word to another one, it's sufficient to press the command TAB.

In order to take place into a word, it's sufficient to use the directional arrows "RIGHT" and "LEFT".

In order to modify the time, it's necessary to use the directional arrow "DOWN" to go into the time window and to press the new one.

The setted data are revised on the encoder only on pressing RETURN on the screen command UPDATE; they are neglected on pressing the screen command EXIT.

G) ON AIR MESSAGES SET

It's used to set/defuse each of the 8 messages and to select the hour and day of the on air putting.

To set/defuse a message it's necessary to press the command SPACE on the keyboard when the cursor is connected with the message. The active messages are where appears a "X".

To change place from the column ACTIVATION to the HOUR one, it's necessary to press the command TAB. It's not realized any check of the hours congruity; it's duty of the user to select different hours for the several messages and time distances between two consecutive messages of at least some minutes. The system automatical provides to put on air the active messages at the preselected hour.

The setted data are revised on the encoder only on pressing ENTER when appears the command REVISE; they are neglected on pressing the command EXIT.

The menu presents as follows:

R.V.R. Elettronica S.r.l.
R D S Encoder TRDS4001 - (Ver. 2.11)

Message list:-

[]	Message number 1	[00:00]
[]	Message number 2	[00:00]
[]	Message number 3	[00:00]
[]	Message number 4	[00:00]
[]	Message number 5	[00:00]
[]	Message number 6	[00:00]
[]	Message number 7	[00:00]
[]	Message number 8	[00:00]

H) RADIO TEXT MESSAGE MANAGEMENT - RT -

This option allows to send messages type TEXT and it's mainly indicated for home RDS receivers.

The text could be composed at most of 8 words, each of no more than 8 characters; the relative menu is the following:

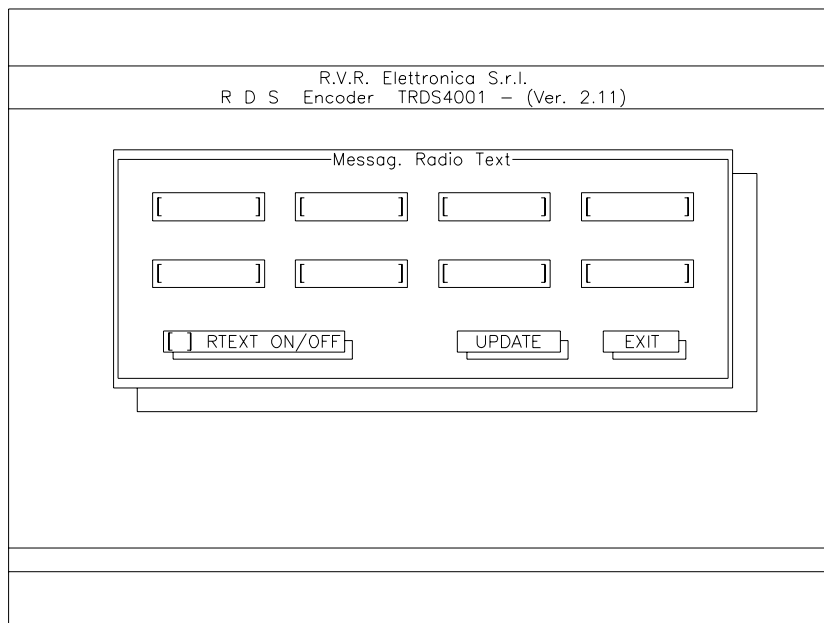

To ability the service "Radio Text" it's necessary to place the cursor on the window "RTEXT ON/OFF" and to press the spacebar; if a "X" appears, the procedure is right.

In order to take place into the text from a word to another one, it's sufficient to use the command TAB; to take place into a word, it's necessary to use the directional arrows "RIGHT" and "LEFT".

The setted data are revised on the encoder only on pressing RETURN on the screen command UPDATE; they are neglected on pressing the screen-command EXIT.

I) EON MESSAGE MANAGEMENT - EON -

This service is used to transmit the PI (Program Identification), il PS (Program service), l'AF (Alternative Frequencies), il PTY (Program Type) and the PIN (Program-item Number) relative at other networks (radio).

This service allows to manage at most 16 networks.

On pressing the voice "EON MESSAGES MANAGEMENT" from the chief menu, a new one will appear: the user has to choose which of the 16 items of the network he wants to set; the new menu shows as follows:

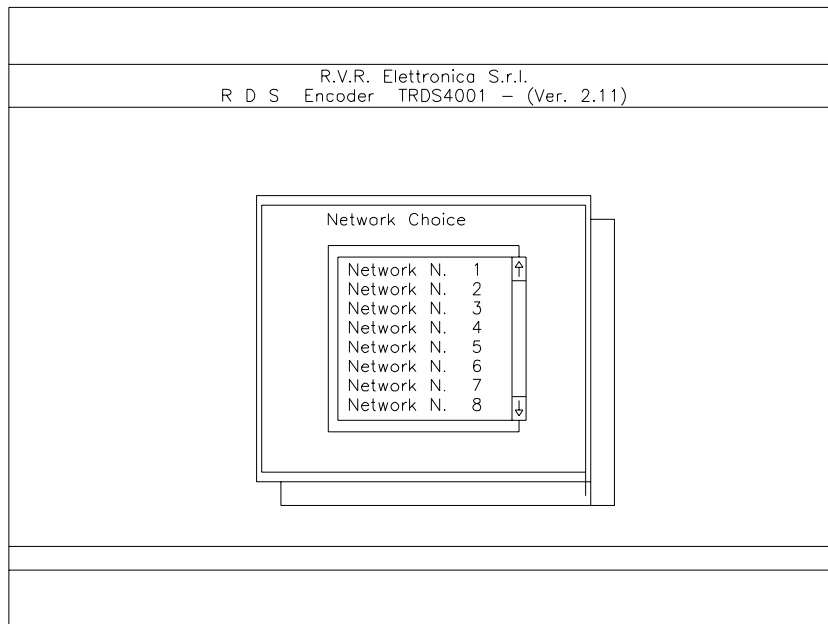

At this point, the user selects one of the 16 items (ex. Network N. 1) and the new menu is the follows:

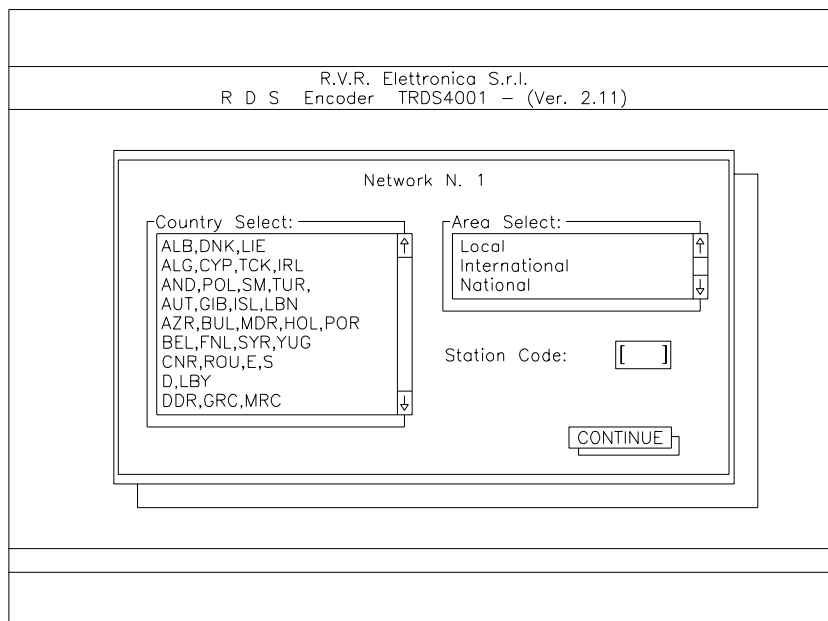

In this menu the system asks the information about Network Program Identification.

To plan, it's necessary to select the country in the window COUNTRY SELECT (ex. command ENTER on I, JOR), to select the covering area on the window AREA SELECT (ex. command ENTER on LOCAL or NATIONAL) and the code (number from 1 to 255).

When all the choices are made, on continuing to realize the further ones, take

place on screen-command "CONTINUE" and press ENTER; at this point a new menu appears as follows:

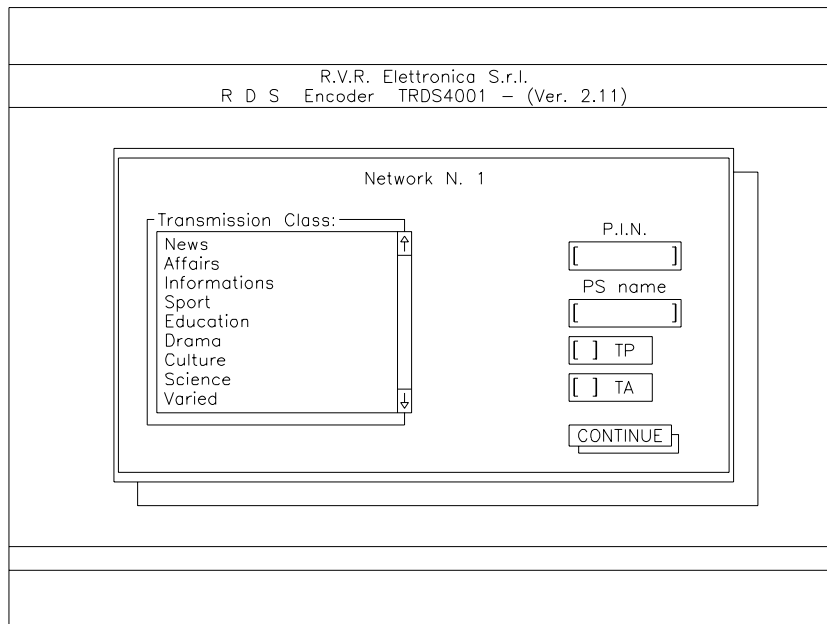

R.V.R. Elettronica S.r.l.
R D S Encoder TRDS4001 - (Ver. 2.11)

Network N. 1

Transmission Class:

- News
- Affairs
- Informations
- Sport
- Education
- Drama
- Culture
- Science
- Varied

P.I.N. []

PS name []

[] TP

[] TA

CONTINUE

In this menu it's possible realize the following settings:

- 1) Program types sended;
- 2) Program-item number (P.I.N.);
- 3) Program service (PS), at most of 8 characters;
- 4) Abilitation of TP services (Traffic-Program Identification), and TA (Traffic-Announcement Identification).

When all the choices are made, on continuing to realize the further ones, take place on the screen command "CONTINUE" and press <ENTER>; at this point a new menu appears as follows:

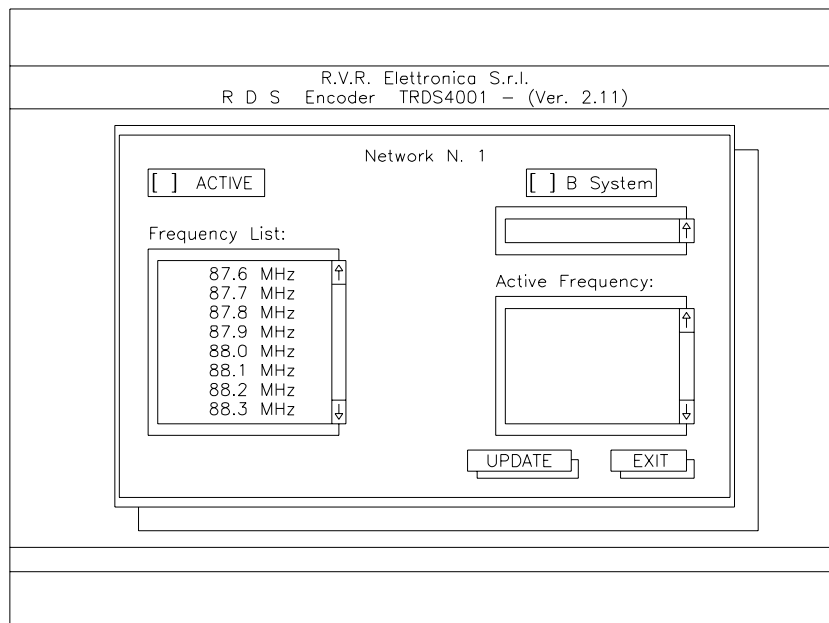

In this menu the user could set the syntony frequencies list of the broadcaster in its diffusion areas.

Also in this case, as in the "Alternative Frequencies Management" one, the program is provided with two methods for the management of the frequencies list, the A, in default setted, and the B one, indicated for very long frequencies lists.

To set the method B, it's necessary to place the cursor on the window "METHOD B" and than press the spacebar; if a "X" appears, the procedure is right.

In addition to this window, on the screen appear other three windows: FREQUENCY LIST, ACTIVE FREQUENCY and ACTIVE.

The windows "FREQUENCY LIST" and "ACTIVE FREQUENCY" contain a frequencies list.

the submultiples of 100 Khz are not admitted by the standard.

On pressing <ENTER> on a frequency into the FREQUENCY LIST, the user selects the frequency which is visualized on the window ACTIVE FREQUENCY.

If the setted frequency is already into the ACTIVE FREQUENCY, the PC utters on indicating the error.

On pressing <ENTER> on a frequency of the ACTIVE FREQUENCY list, the user cancels the same frequency.

The window ACTIVE allows to set or to defuse the EON message; to ability it, place the cursor on the window "ACTIVE" and press the spacebar; if a "X" appears, the procedure is right.

The setted data within this moment are revised on the encoder only on pressing <ENTER> when appears the screen command UPDATE; they are neglected on pressing the screen command EXIT.

L) TRANSPARENT CHANNEL MANAGEMENT - TDC -

This option is used for the transmission of any type of data.

The text could be composed at most from 8 words, each of 8 characters; the menu shows as follows:

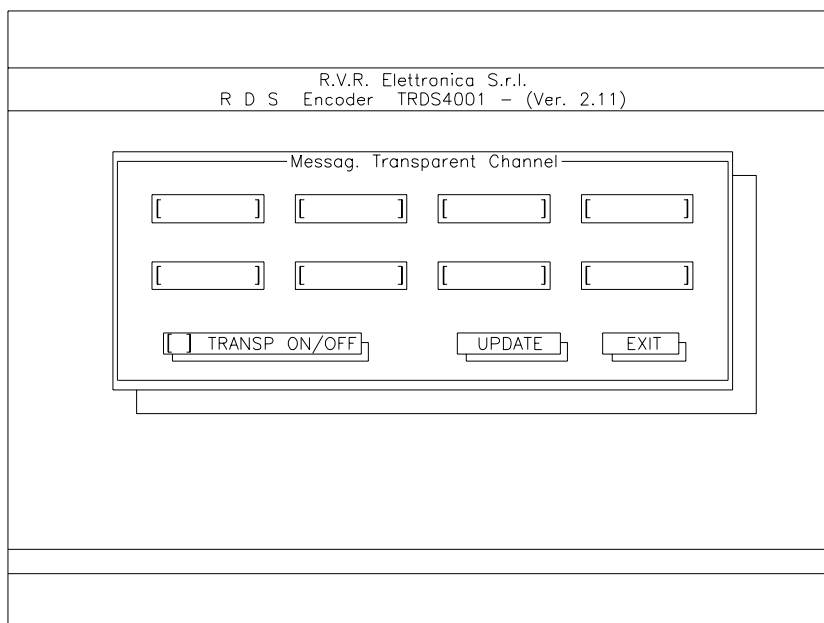

To ability the service "Transparent Data Channel", it's necessary to place the cursor on the window "TRANSP. ON/OFF" and to press the spacebar; if a "X" appears, the procedure is right.

To take place into a text from a word to another one, it's sufficient to use the command "TAB"; to take place into a word, on utilizing the directional arrows "RIGHT" and "LEFT".

The setted data are revised on the encoder on pressing <ENTER> on the screen-command UPDATE; they are neglected on pressing the screen-command EXIT.

M) MESSAGE MANAGEMENT IN HOUSE - IH -

This option is used for the trasmission of the data of exclusiv use of the radio broadcaster and it could be used, for ex., for the transmission of telemetry data, software, etc.

The text could be composed at most of 8 words, each of at most 8 characters; the new menu is the following:

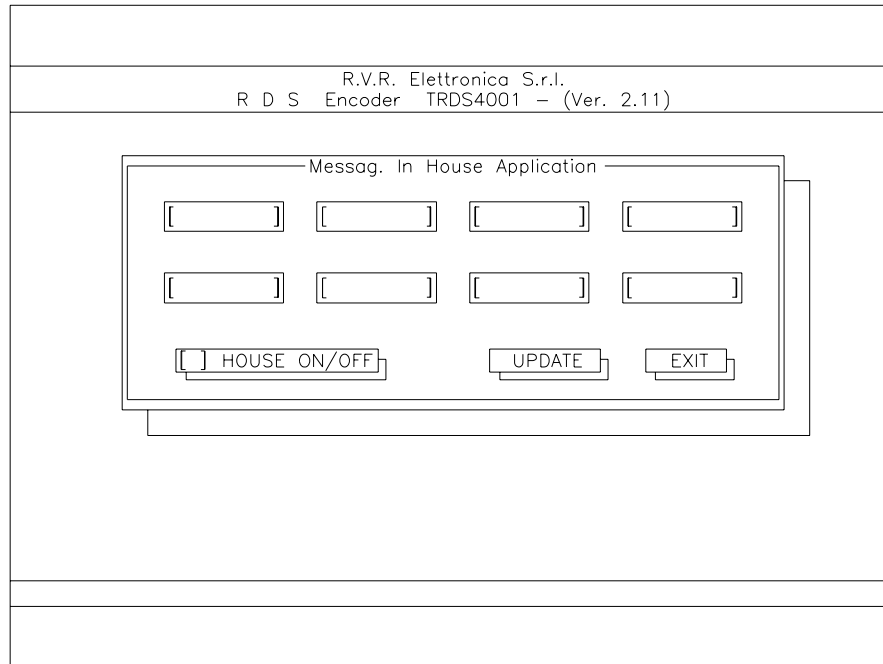

To ability the service "IN House Application", it's necessary to place the cursor on the window "HOUSE ON/OFF" and press the spacebar; if a "X" appears, the procedure is right.

To take place into a text from a word to another one, use the command "TAB"; to take place into a word, use the directional arrows "RIGHT" and "LEFT".

The setted data are revised on the encoder on pressing <ENTER> on the screen-command "UPDATE"; they are neglected on pressing the screen-command "EXIT".

N) TIMDE/DATE SET

This option allows the reading and the setting of the into clock /calendar date and hour, whose the program is provided with.

Date and hour, as so read by the encoder, appear on the screen on the left side; on the right side, the user could see the PC date and hour, at the moment in which is read the encoder clock.

The date and hour setted on the window on the left are transfered on the encoder at the moment of pressing the screen-command UPDATE.

No revising are realized on pressing the screen command EXIT.

The menu shows as follows:

R.V.R. Elettronica S.r.l. R D S Encoder TRDS4001 - (Ver. 2.11)	
<div style="border: 1px solid black; padding: 5px; margin-bottom: 5px;"> <p>Target Time/Date</p> <p>[22:28:02]</p> <p>[11/01/97]</p> </div> <div style="border: 1px solid black; padding: 5px; margin-bottom: 5px;"> <p>22:34:50</p> </div>	<div style="border: 1px solid black; padding: 5px; margin-bottom: 5px;"> <p>PC Time/Date</p> <p>22:24:26</p> <p>11/07/97</p> </div> <div style="text-align: right; margin-top: 10px;"> <input type="button" value="UPDATE"/> <input type="button" value="EXIT"/> </div>

The TRDS4001/SAT Encoder version, in the chief menu, is provided with a further option, as follows:

O) STATION SELECTION

The RDS SAT version codifier provides the messages planning with a directly connected Pc and with a remote connection of the PC to the UP-LINK transmitter.

In this case, the several codifiers are identified by an internal 8 bits code (from 1 to 255) in EPROM memorized; when the user wants to modify a codifier message, he has to know the relative code.

The several codes are listed into the record "STATION.DAT", which is realized and modified by a standard EDITOR. The record provides 4 useful fields to the encoder identification which are separated by commas:

- 1) Code, 3 numerals number (from 1 to 255). The codes more shortly than 3 numerals have to be preceded by spaces;
- 2) Address, alphanumeric field at most of 30 characters;
- 3) Place, alphanumeric field at most of 25 characters;
- 4) District, 2 characters field.

The supplied management program uses only the field 1 for the encoder addressing; the other ones could contain the informations that the user considers more proper. The only bond to respect is NOT EXCEED the presetted characters limit. Into the record STATION.DOC, two encoder could not have the same code.

This option allows to select 1,2,.....N, all the encoders (identified by the station where they are placed in) to send the message to; if no encoder is selected, none of the other voices into the chief menu are settable.

SAT CONNECTION VERSION

The RDS codifier in UP-LINK version for SAT presents some peculiarities compared with the other codifiers which are specified in this chapter.

A) The software in kit provides two programs: RDSSATTX and RDSSATPC.

The RDSSATTX program is useable with the connection of the Pc to the SAT transmitter.

This program takes and memorizes the several messages information from the file on disk /directorate where the program is placed in, in absence of confirmation by the selected codifier. Therefore, we recommend to make files copies whenever the user modifies a message.

The revised files by RDSSATTX are `FREQ.BIN`, `ID.BIN`, `MSG.BIN`, `PROG.BIN`, `TYPE.BIN`.

The RDSSATPC program is useable with the connection of the PC to the RDS codifier. This program receives the information on directly asking to the preselected codifier, on setting the voice into the chief menu `POST.SELECT`.

This program is working for one station at a time.

P) EXIT

On setting this option the program ends and returns the cheking to the PC DOS operative system. The PC could be disconnected by the codifier.

This page was intentionally left blank

Appendix A Piani di montaggio, schemi elettrici, liste componenti / *Component layouts, schematics, bills of material*

Questa parte del manuale contiene i dettagli tecnici riguardanti la costruzione delle singole schede componenti il SDC100. L'appendice è composta dalle seguenti sezioni:

This part of the manual contains the technical details about the different boards of the SDC100. This appendix is composed of the following sections:

Description	RVR Code	Vers.	Pages
Wiring diagram	/	1.0	2
Power supply card	CSSWPSUP0003	1.1	4
Pannel card	CSSDC100PA02	1.0	4
Mother board	SLSDC100MB01	1.0	8
Stereo Coder Card	CSSTCOD03	1.1	6
	SLPTCODSTE02 (before february 2001)	1.0	4
R.D.S. card	CSSDCRDS003	1.1	8
CPU card	SLPTCPU55202	1.0	4

Pagina lasciata intenzionalmente in bianco
This page intentionally left blank

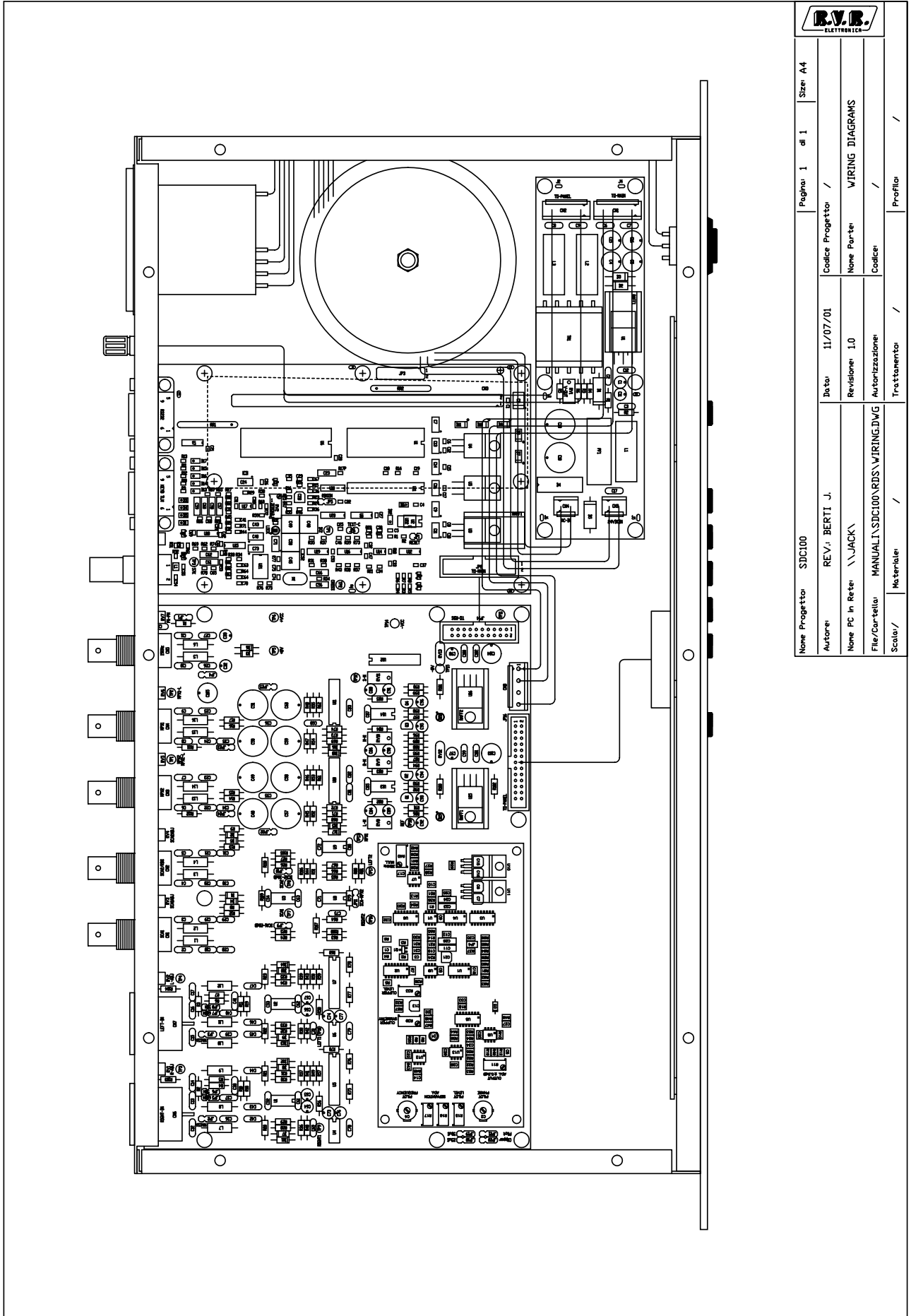

		Pagina 1	di 1	Size: A4
Nome Progetto:	SDC100	Data:	11/07/01	Codice Progetto: /
Autore:	REV.: BERTI J.	Revisione:	1.0	Nome Parte: WIRING DIAGRAMS
Nome PC in Rete:	\\JACK\	Autorezzazione:	/	Codice: /
File/Cartella:	MANUAL\SDC100\RD5\WIRING.DWG	Trattamento:	/	Profilo: /
Scala:	/	Materiali:	/	

Pagina lasciata intenzionalmente in bianco
This page was intentionally left blank

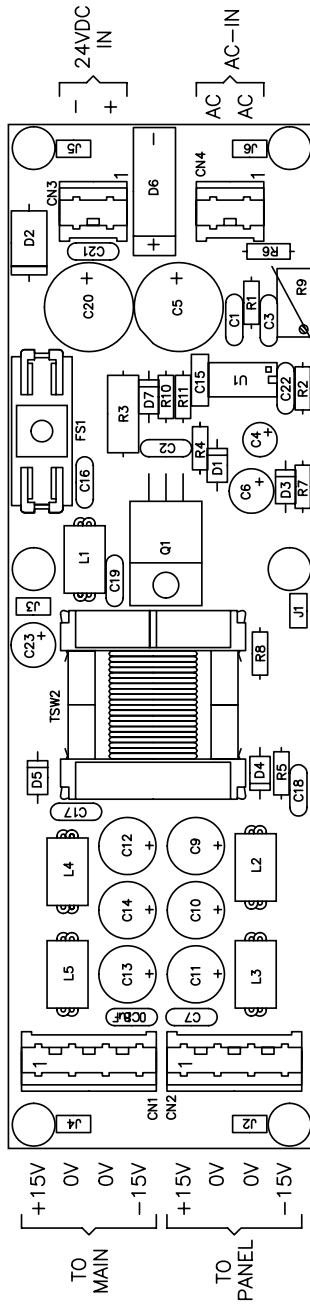

		Nome Progetto: SDC100	Pagina: 1	di 1	Size: A4
Autore: REV.: BERTI J.	Data: 11/07/01	Codice Progetto: /			
Nome PC in Rete: \\JACK\	Revisione: 1.0	Nome Parte: POWER SUPPLY COMPONENT LAYOUT			
File/Cartella: MANUALE\SDC100\PIRESUP\NUM_SDC.DWG	Autorizzazione:	Codice: CSSWFSUP0003			
Scala: /	Materiale: /	Treatmento: /	Profilo: /		

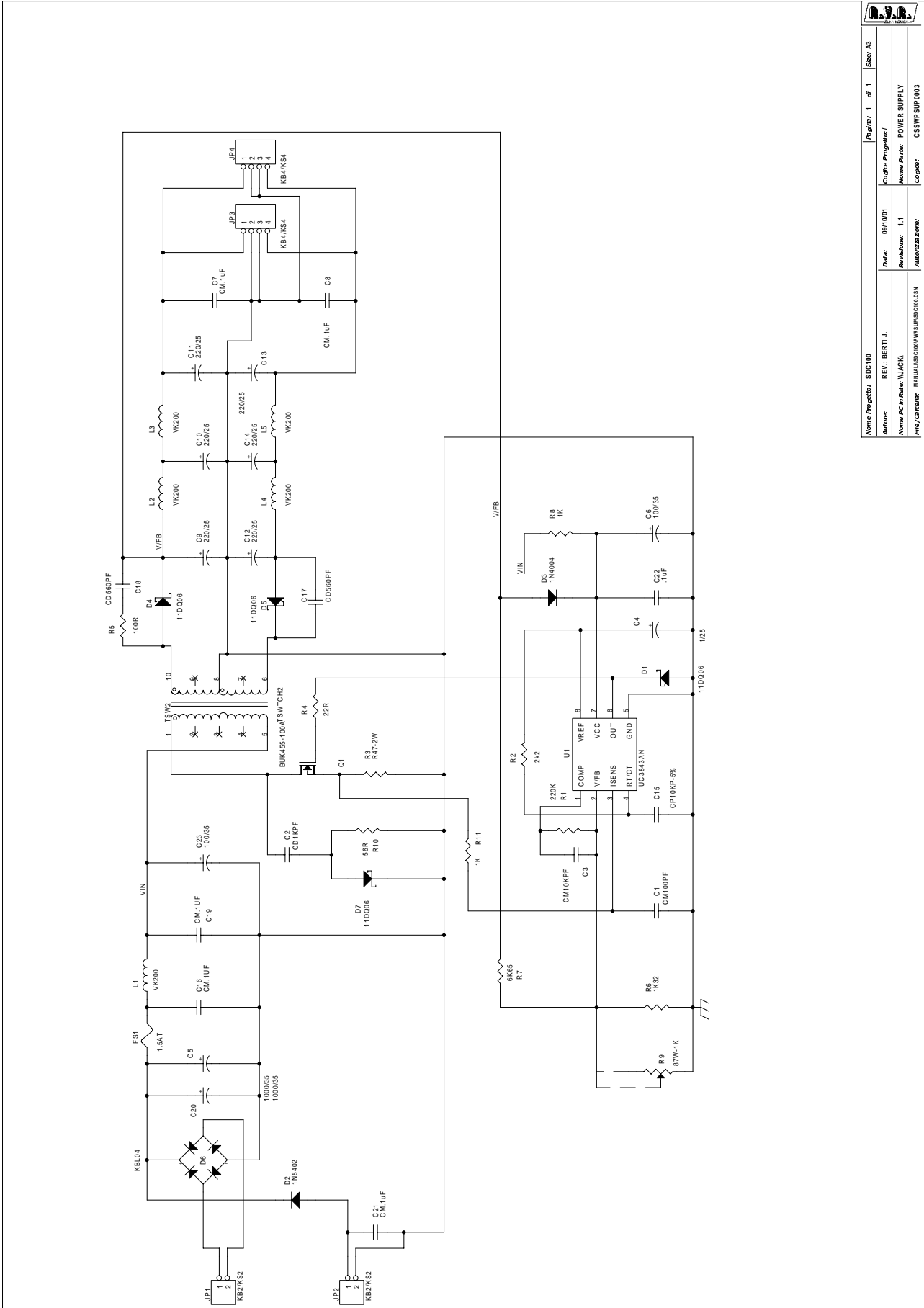

Nome Progetto:	SDC100	Progetto:	1	di	1	Sheet:	A3
Autore:	REV.: BERTI J.	Codice Progetto/					
Nome PC o Rete:	UJACK	Revisione:	1.1	Nome File: POWER SUPPLY			
File/Contenuto:	MANUALI/SDC100/PWR/SUP/SDC100.DSN	Autore:					
		Codice:	CSSWPSUP003				

CSSDC100PA02 Bill Of Materials Page1

ItemQuantity Reference Part

1	1	C1	CM100PF
2	1	C2	CD1KPF
3	1	C3	CM10KPF
4	1	C4	1/25
5	2	C5,C20	1000/35
6	2	C6,C23	100/35
7	5	C7,C8,C16,C19,C21	CM.1uF
8	6	C9,C10,C11,C12,C13,C14	220/25
9	1	C15	CP10KP-5%
10	2	C17,C18	CD560PF
11	1	C22	.1uF
12	4	D1,D4,D5,D7	11DQ06
13	1	D2	1N5402
14	1	D3	1N4004
15	1	D6	KBL04
16	1	FS1	1.5AT
17	2	JP1,JP2	KB2/KS2
18	2	JP3,JP4	KB4/KS4
19	5	L1,L2,L3,L4,L5	VK200
20	1	Q1	BUK455-100A
21	1	R1	220K
22	1	R2	2K2
23	1	R3	R47-2W
24	1	R4	22R
25	1	R5	100R
26	1	R6	1K32
27	1	R7	6K65
28	1	R9	87W-1K
29	1	R10	56R
30	1	R8, R11	1K
31	1	TSW2	TSWTCH2
32	1	U1	UC3843AN

Pagina lasciata intenzionalmente in bianco
This page was intentionally left blank

SLSDC100PA02

Bill of Materials

Item	Reference	Part	Description	RVRCode
1	CS1	CS	Circuito stampato	CSSDC100PA02
2	C1	0.1uF	Cond. ceramico p. 5mm	CKM104BK600P
3	C2	10uF	Cond. el. ver. 16V p. 2.5mm	CEA106BM160
4	U2	LM3915	CI lineare	CILLM3915
5	U1	LM3915	CI lineare	CILLM3915
6	C6	0.1uF	Cond. ceramico p. 5mm	CKM104BK600P
7	C3	0.1uF	Cond. ceramico p. 5mm	CKM104BK600P
8	C5	10uF	Cond. el. ver. 16V p. 2.5mm	CEA106BM160
9	U5	LM3915	CI lineare	CILLM3915
10	U3	LM3915	CI lineare	CILLM3915
11	C7	0.1uF	Cond. ceramico p. 5mm	CKM104BK600P
12	C4	100uF	Cond. el. ver. 25V p. 2.5mm	CEA107AM250
13	R1	390	Res. 1/4 W 1%	RSM1/4FH0390
14	SW6	SWMEC4	Commutatore	SWMEC4
15	SW4	SWMEC4	Commutatore	SWMEC4
16	SW5	SWMEC4	Commutatore	SWMEC4
17	SW3	SWMEC4	Commutatore	SWMEC4
18	SW1	SWMEC4	Commutatore	SWMEC4
19	SW7	SWMEC4	Commutatore	SWMEC4
20	SW2	SWMEC4	Commutatore	SWMEC4
21	R2	390	Res. 1/4 W 1%	RSM1/4FH0390
22	U4	LM358	CI lineare	CILLM358
23	R17	1K	Res. 1/4 W 1%	RSM1/4FK0001
24	R7	3K30	Res. 1/4 W 1%	RSM1/4FK03,3
25	R6	3K30	Res. 1/4 W 1%	RSM1/4FK03,3
26	R8	1K0	Res. 1/4 W 1%	RSM1/4FK0001
27	R16	3K30	Res. 1/4 W 1%	RSM1/4FK03,3
28	R14	3K30	Res. 1/4 W 1%	RSM1/4FK03,3
29	R19	1K0	Res. 1/4 W 1%	RSM1/4FK0001
30	R18	4K42	Res. 1/4 W 1%	RSM1/4FK4,42
31	R15	137K0	Res. 1/4 W 1%	RSM1/4FK0137
32	R4	137K0	Res. 1/4 W 1%	RSM1/4FK0137
33	R5	4K42	Res. 1/4 W 1%	RSM1/4FK4,42
34	D1	LED-G	Led Verde Quadro 5x5 mm	LEDVEQ5
35	D2	LED-G	Led Verde Quadro 5x5 mm	LEDVEQ5
36	D3	LED-G	Led Verde Quadro 5x5 mm	LEDVEQ5
37	D4	LED-G	Led Verde Quadro 5x5 mm	LEDVEQ5
38	D5	LED-G	Led Verde Quadro 5x5 mm	LEDVEQ5
39	D6	LED-G	Led Verde Quadro 5x5 mm	LEDVEQ5
40	D7	LED-G	Led Verde Quadro 5x5 mm	LEDVEQ5
41	D8	LED-G	Led Verde Quadro 5x5 mm	LEDVEQ5
42	D9	LED-G	Led Verde Quadro 5x5 mm	LEDVEQ5
43	D10	LED-G	Led Verde Quadro 5x5 mm	LEDVEQ5
44	D11	LED-G	Led Verde Quadro 5x5 mm	LEDVEQ5
45	D12	LED-G	Led Verde Quadro 5x5 mm	LEDVEQ5
46	D13	LED-G	Led Verde Quadro 5x5 mm	LEDVEQ5
47	D14	LED-G	Led Verde Quadro 5x5 mm	LEDVEQ5
48	D15	LED-G	Led Verde Quadro 5x5 mm	LEDVEQ5
49	D16	LED-G	Led Verde Quadro 5x5 mm	LEDVEQ5
50	D30	LED-G	Led Verde Quadro 5x5 mm	LEDVEQ5
51	D31	LED-G	Led Verde Quadro 5x5 mm	LEDVEQ5
52	D32	LED-G	Led Verde Quadro 5x5 mm	LEDVEQ5
53	D33	LED-G	Led Verde Quadro 5x5 mm	LEDVEQ5
54	D34	LED-G	Led Verde Quadro 5x5 mm	LEDVEQ5
55	D35	LED-G	Led Verde Quadro 5x5 mm	LEDVEQ5

56	D36	LED-G	Led Verde Quadro 5x5 mm	LEDVEQ5
57	D37	LED-G	Led Verde Quadro 5x5 mm	LEDVEQ5
58	D38	LED-G	Led Verde Quadro 5x5 mm	LEDVEQ5
59	D39	LED-G	Led Verde Quadro 5x5 mm	LEDVEQ5
60	D40	LED-G	Led Verde Quadro 5x5 mm	LEDVEQ5
61	D41	LED-G	Led Verde Quadro 5x5 mm	LEDVEQ5
62	D42	LED-G	Led Verde Quadro 5x5 mm	LEDVEQ5
63	D43	LED-G	Led Verde Quadro 5x5 mm	LEDVEQ5
64	D44	LED-G	Led Verde Quadro 5x5 mm	LEDVEQ5
65	D45	LED-G	Led Verde Quadro 5x5 mm	LEDVEQ5
66	D18	LED-R	Led Rosso Quadro 5x5 mm	LEDROQ5
67	D19	LED-R	Led Rosso Quadro 5x5 mm	LEDROQ5
68	D20	LED-R	Led Rosso Quadro 5x5 mm	LEDROQ5
69	D49	LED-R	Led Rosso Quadro 5x5 mm	LEDROQ5
70	D48	LED-R	Led Rosso Quadro 5x5 mm	LEDROQ5
71	D47	LED-R	Led Rosso Quadro 5x5 mm	LEDROQ5
72	R3	390H0	Res. 1/4 W 1%	RSM1/4FH0390
73	R9	390H0	Res. 1/4 W 1%	RSM1/4FH0390
74	R10	390H0	Res. 1/4 W 1%	RSM1/4FH0390
75	R11	390H0	Res. 1/4 W 1%	RSM1/4FH0390
76	R12	390H0	Res. 1/4 W 1%	RSM1/4FH0390
77	R13	390H0	Res. 1/4 W 1%	RSM1/4FH0390
78	R22	56H0	Res. 1/4 W 1%	RSM1/4FH0056
79	D22	LED-G	Led Verde Quadro 5x5 mm	LEDVEQ5
80	D29	LED-G	Led Verde Quadro 5x5 mm	LEDVEQ5
81	D28	LED-G	Led Verde Quadro 5x5 mm	LEDVEQ5
82	D27	LED-G	Led Verde Quadro 5x5 mm	LEDVEQ5
83	D26	LED-G	Led Verde Quadro 5x5 mm	LEDVEQ5
84	D25	LED-G	Led Verde Quadro 5x5 mm	LEDVEQ5
85	D24	LED-G	Led Verde Quadro 5x5 mm	LEDVEQ5
86	D23	LED-G	Led Verde Quadro 5x5 mm	LEDVEQ5
87	D21	LED-G	Led Verde Quadro 5x5 mm	LEDVEQ5
88	CN1	CN04MR	Conn. morsetto 04 pin F c.s.	CNMRS04R
89	R20	18K	Res. 1/4 W 5%	RSC1/4JK0018
90	R21	18K	Res. 1/4 W 5%	RSC1/4JK0018
91	D17	LED-Y	Led Giallo Quadro 5x5 mm	LEDGIQ5
92	D46	LED-Y	Led Giallo Quadro 5x5 mm	LEDGIQ5
93	JP1	CN26PD	Conn. M cs 2x2.54mm a 26 pin.	CNTMCSFC26P
94	R23	0	Res.	

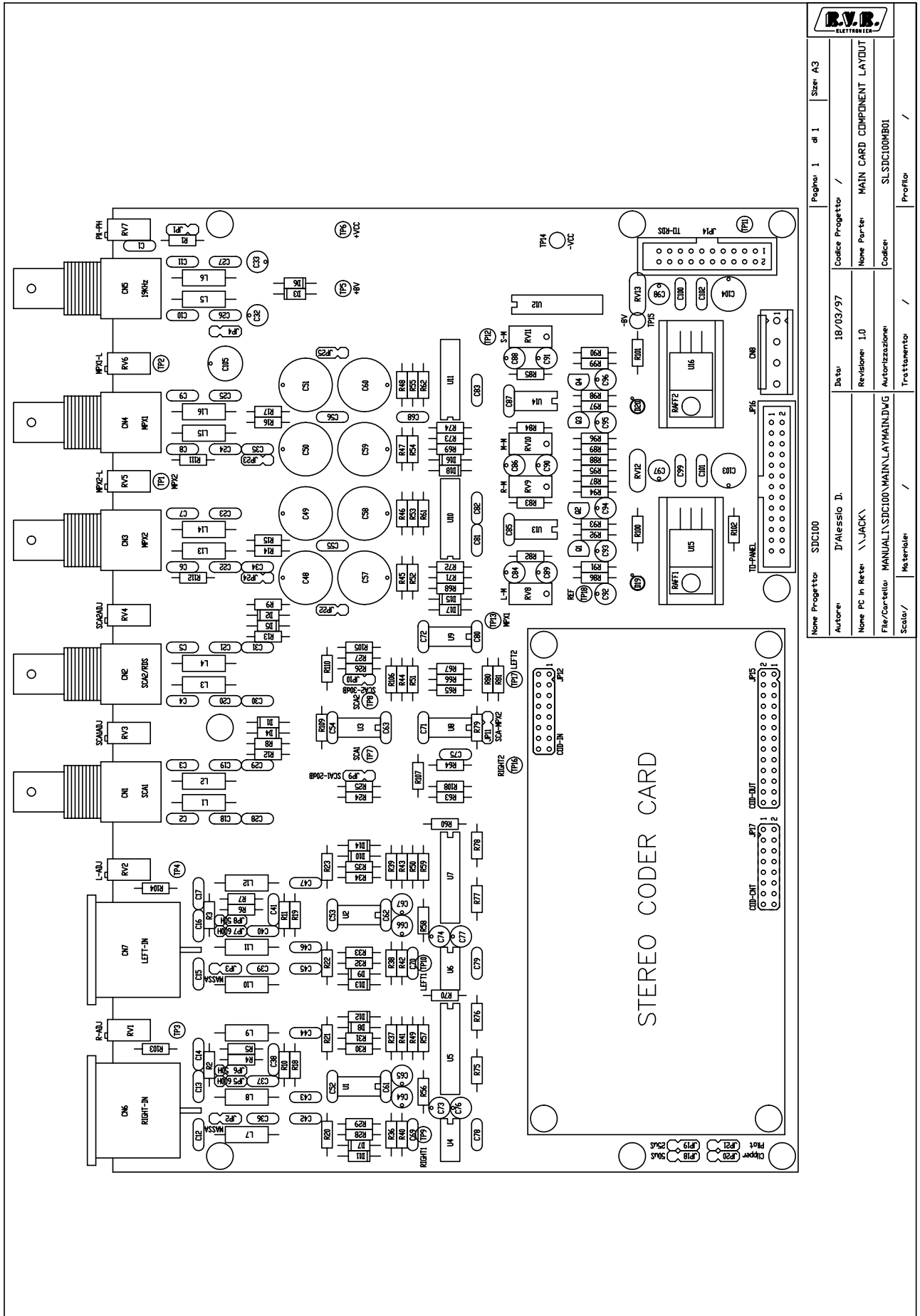

Nome Progettista: SDC100		Pagina: 1 di 1		Size: A3	
Autore: D'Alessio D.		Data: 18/03/97		Codice Progettista: /	
Nome PC in Rete: \JACK\		Revisione: 1.0		Nome Parte: MAIN CARD COMPONENT LAYOUT	
File/Carrello: MANUAL\SDC100\MAIN\LAYMAIN.DWG		Autore/Revisione:		Codice: SLSDC100MB01	
Scala: /		Materiale: /		Trattamento: /	
				Profilo: /	

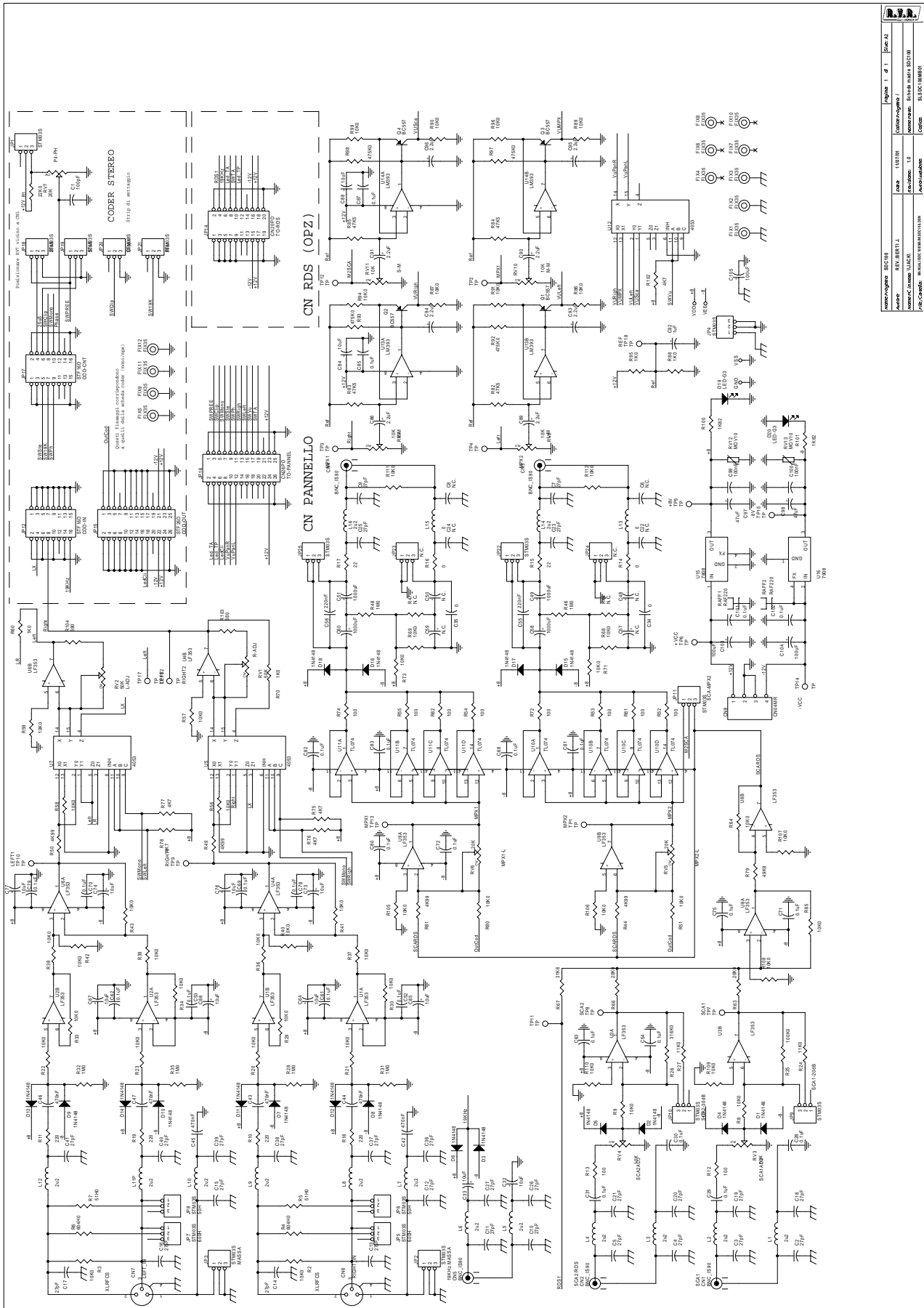

Nome Progetto	SDC100	Revisione	1.0	Page 1 di 2
Autore	REV.001/1.0	Controllato	1.0	
Autore	REV.001/1.0	Autore	REV.001/1.0	
Autore	REV.001/1.0	Autore	REV.001/1.0	
Autore	REV.001/1.0	Autore	REV.001/1.0	

SLSDC100MB01

Bill of Materials

Item	Reference	Part	Description	RVRCode
1	CS1	CS	Circuito stampato	
2	R13	100	Res. 1/4 W 5%	
3	R39	10K0	Res. 1/4 W 1%	
4	R43	10K0	Res. 1/4 W 1%	
5	R9	10K0	Res. 1/4 W 1%	
6	R27	11K0	Res. 1/4 W 1%	
7	R66	20K0	Res. 1/4 W 1%	
8	R91	10K0	Res. 1/4 W 1%	
9	R86	10K0	Res. 1/4 W 1%	
10	R87	10K0	Res. 1/4 W 1%	
11	R83	47K5	Res. 1/4 W 1%	
12	R82	47K5	Res. 1/4 W 1%	
13	R92	475K0	Res. 1/4 W 1%	
14	R80	10K0	Res. 1/4 W 1%	
15	C11	27pF	Cond. ceramico p. 5mm	
16	C27	27pF	Cond. ceramico p. 5mm	
17	C41	27pF	Cond. ceramico p. 5mm	
18	C5	27pF	Cond. ceramico p. 5mm	
19	C21	27pF	Cond. ceramico p. 5mm	
20	C31	0.1uF	Cond. ceramico p. 5mm	
21	C93	2.2uF	Cond. el. ver. 16V p. 2.5mm	
22	C94	2.2uF	Cond. el. ver. 16V p. 2.5mm	
23	C16	27pF	Cond. ceramico p. 5mm	
24	C40	27pF	Cond. ceramico p. 5mm	
25	Q1	BC557	Tr. in TO 92	
26	R37	10K0	Res. 1/4 W 1%	
27	R41	10K0	Res. 1/4 W 1%	
28	R24	11K0	Res. 1/4 W 1%	
29	R63	20K0	Res. 1/4 W 1%	
30	R96	10K0	Res. 1/4 W 1%	
31	R89	10K0	Res. 1/4 W 1%	
32	R90	10K0	Res. 1/4 W 1%	
33	R99	10K0	Res. 1/4 W 1%	
34	R85	47K5	Res. 1/4 W 1%	
35	R84	47K5	Res. 1/4 W 1%	
36	C95	2.2uF	Cond. el. ver. 16V p. 2.5mm	
37	C96	2.2uF	Cond. el. ver. 16V p. 2.5mm	
38	Q4	BC557	Tr. in TO 92	
39	Q3	BC557	Tr. in TO 92	
40	R67	31K6	Res. 1/4 W 1%	
41	C70	0.1uF	Cond. ceramico p. 5mm	
42	C79	0.1uF	Cond. ceramico p. 5mm	
43	C78	0.1uF	Cond. ceramico p. 5mm	
44	C69	0.1uF	Cond. ceramico p. 5mm	
45	C63	0.1uF	Cond. ceramico p. 5mm	
46	C54	0.1uF	Cond. ceramico p. 5mm	
47	C75	0.1uF	Cond. ceramico p. 5mm	
48	C71	0.1uF	Cond. ceramico p. 5mm	
49	R65	10K0	Res. 1/4 W 1%	
50	R93	475K0	Res. 1/4 W 1%	
51	R97	475K0	Res. 1/4 W 1%	
52	R98	475K0	Res. 1/4 W 1%	
53	C89	2.2uF	Cond. el. ver. 16V p. 2.5mm	
54	C86	2.2uF	Cond. el. ver. 16V p. 2.5mm	
55	C90	2.2uF	Cond. el. ver. 16V p. 2.5mm	

56	C91	2.2uF	Cond. el. ver. 16V p. 2.5mm
57	C10	27pF	Cond. ceramico p. 5mm
58	C26	27pF	Cond. ceramico p. 5mm
59	C15	27pF	Cond. ceramico p. 5mm
60	C39	27pF	Cond. ceramico p. 5mm
61	C4	27pF	Cond. ceramico p. 5mm
62	C20	27pF	Cond. ceramico p. 5mm
63	R12	100	Res. 1/4 W 5%
64	C3	27pF	Cond. ceramico p. 5mm
65	C19	27pF	Cond. ceramico p. 5mm
66	C29	0.1uF	Cond. ceramico p. 5mm
67	C2	27pF	Cond. ceramico p. 5mm
68	C18	27pF	Cond. ceramico p. 5mm
69	R8	10K0	Res. 1/4 W 1%
70	C24	N.C.	
71	C8	N.C.	
72	C25	27pF	Cond. ceramico p. 5mm
73	C9	27pF	Cond. ceramico p. 5mm
74	D4	1N4148	Diodo silicio
75	D1	1N4148	Diodo silicio
76	C33	10uF	Cond. el. ver. 16V p. 2.5mm
77	D6	1N4148	Diodo silicio
78	R42	10K0	Res. 1/4 W 1%
79	D14	1N4148	Diodo silicio
80	D5	1N4148	Diodo silicio
81	D2	1N4148	Diodo silicio
82	C30	0.1uF	Cond. ceramico p. 5mm
83	R26	316K0	Res. 1/4 W 1%
84	R25	100K0	Res. 1/4 W 1%
85	C28	0.1uF	Cond. ceramico p. 5mm
86	D18	1N4148	Diodo silicio
87	D16	1N4148	Diodo silicio
88	R40	10K0	Res. 1/4 W 1%
89	R36	10K0	Res. 1/4 W 1%
90	R38	10K0	Res. 1/4 W 1%
91	R34	10K0	Res. 1/4 W 1%
92	C53	0.1uF	Cond. ceramico p. 5mm
93	C62	0.1uF	Cond. ceramico p. 5mm
94	R23	10K0	Res. 1/4 W 1%
95	D13	1N4148	Diodo silicio
96	D3	1N4148	Diodo silicio
97	R22	10K0	Res. 1/4 W 1%
98	R33	10K0	Res. 1/4 W 1%
99	R11	220	Res. 1/4 W 5%
100	R19	220	Res. 1/4 W 5%
101	R7	51H0	Res. 1/4 W 1%
102	C17	27pF	Cond. ceramico p. 5mm
103	R3	10K0	Res. 1/4 W 1%
104	C38	27pF	Cond. ceramico p. 5mm
105	C13	27pF	Cond. ceramico p. 5mm
106	C37	27pF	Cond. ceramico p. 5mm
107	C12	27pF	Cond. ceramico p. 5mm
108	C36	27pF	Cond. ceramico p. 5mm
109	D12	1N4148	Diodo silicio
110	R30	10K0	Res. 1/4 W 1%
111	C52	0.1uF	Cond. ceramico p. 5mm
112	C61	0.1uF	Cond. ceramico p. 5mm
113	R21	10K0	Res. 1/4 W 1%
114	R20	10K0	Res. 1/4 W 1%

115	R29	10K0	Res. 1/4 W 1%
116	R10	220	Res. 1/4 W 5%
117	R18	220	Res. 1/4 W 5%
118	R5	51H0	Res. 1/4 W 1%
119	C14	27pF	Cond. ceramico p. 5mm
120	R2	10K0	Res. 1/4 W 1%
121	D11	1N4148	Diode silicio
122	C32	10uF	Cond. el. ver. 16V p. 2.5mm
123	D8	1N4148	Diode silicio
124	D7	1N4148	Diode silicio
125	D9	1N4148	Diode silicio
126	D10	1N4148	Diode silicio
127	C82	0.1uF	Cond. ceramico p. 5mm
128	C83	0.1uF	Cond. ceramico p. 5mm
129	R69	10K	Res. 1/4 W 1%
130	C56	220nF	Cond. ceramico p. 5mm
131	C35	0	Res.
132	RAFF1	RAF220	Dissipatore per TO220
133	R100	1K82	Res. 1/4 W 1%
134	C97	47uF	Cond. el. ver. 16V p. 2.5mm
135	R101	1K82	Res. 1/4 W 1%
136	C98	47uF	Cond. el. ver. 16V p. 2.5mm
137	C99	100nF	Cond. ceramico p. 5mm
138	C100	100nF	Cond. ceramico p. 5mm
139	RV12	MOV10	Varistor MOV10
140	RV13	MOV10	Varistor MOV10
141	CN8	CN04MR	Conn. morsetto 04 pin F c.s.
142	C22	N.C.	
143	C6	N.C.	
144	C23	27pF	Cond. ceramico p. 5mm
145	C7	27pF	Cond. ceramico p. 5mm
146	D17	1N4148	Diode silicio
147	D15	1N4148	Diode silicio
148	R68	10K	Res. 1/4 W 1%
149	C55	220nF	Cond. ceramico p. 5mm
150	C34	0	Res.
151	U1	LF353	CI lineare
152	U6	LF353	CI lineare
153	U4	LF353	CI lineare
154	U7	4053	CI digitale
155	U5	4053	CI digitale
156	U3	LF353	CI lineare
157	U8	LF353	CI lineare
158	U13	LM393	CI lineare
159	U14	LM393	CI lineare
160	U12	4053	CI digitale
161	U15	7808	CI lineare
162	U16	7908	CI lineare
163	U2	LF353	CI lineare
164	C101	0.1uF	Cond. ceramico p. 5mm
165	C102	0.1uF	Cond. ceramico p. 5mm
166	RAFF2	RAF220	Dissipatore per TO220
167	C92	1uF	Cond. el. ver. 16V p. 2.5mm
168	JP1	STM03S	Strip M 2.54 3 pin.
169	R1	22K0	Res. 1/4 W 1%
170	JP4	STM03S	Strip M 2.54 3 pin.
171	C103	100uF	Cond. el. ver. 25V p. 2.5mm
172	C104	100uF	Cond. el. ver. 25V p. 2.5mm
173	C88	10uF	Cond. el. ver. 16V p. 2.5mm
174	C87	0.1uF	Cond. ceramico p. 5mm

175	C84	10uF	Cond. el. ver. 16V p. 2.5mm
176	C85	0.1uF	Cond. ceramico p. 5mm
177	C66	10uF	Cond. el. ver. 16V p. 2.5mm
178	C67	10uF	Cond. el. ver. 16V p. 2.5mm
179	C64	10uF	Cond. el. ver. 16V p. 2.5mm
180	C65	10uF	Cond. el. ver. 16V p. 2.5mm
181	C77	10uF	Cond. el. ver. 16V p. 2.5mm
182	C74	10uF	Cond. el. ver. 16V p. 2.5mm
183	C76	10uF	Cond. el. ver. 16V p. 2.5mm
184	C73	10uF	Cond. el. ver. 16V p. 2.5mm
185	R73	10K	Res. 1/4 W 1%
186	R49	4K99	Res. 1/4 W 1%
187	R50	4K99	Res. 1/4 W 1%
188	R77	4K7	Res. 1/4 W 1%
189	R78	4K7	Res. 1/4 W 1%
190	R76	4K7	Res. 1/4 W 1%
191	R75	4K7	Res. 1/4 W 1%
192	R94	10K0	Res. 1/4 W 1%
193	Q2	BC557	Tr. in TO 92
194	R17	22	Res. 1/4 W 1%
195	R16	0	Res.
196	R15	22	Res. 1/4 W 1%
197	R14	0	Res.
198	U11	TL074	CI lineare
199	R74	100	Res. 1/4 W 1%
200	R55	100	Res. 1/4 W 1%
201	R62	100	Res. 1/4 W 1%
202	R54	100	Res. 1/4 W 1%
203	U10	TL074	CI lineare
204	R72	100	Res. 1/4 W 1%
205	R53	100	Res. 1/4 W 1%
206	R61	100	Res. 1/4 W 1%
207	R52	100	Res. 1/4 W 1%
208	R71	10K	Res. 1/4 W 1%
209	U9	LF353	CI lineare
210	R64	10K	Res. 1/4 W 1%
211	C80	0.1uF	Cond. ceramico p. 5mm
212	C72	0.1uF	Cond. ceramico p. 5mm
213	C68	0.1uF	Cond. ceramico p. 5mm
214	C81	0.1uF	Cond. ceramico p. 5mm
215	R102	4K7	Res. 1/4 W 1%
216	R95	1K0	Res. 1/4 W 1%
217	R88	1K0	Res. 1/4 W 1%
218	C58	1000uF	Cond. el. ver. 25V p. 2.5mm
219	C49	1000uF	Cond. el. ver. 25V p. 2.5mm
220	C48	N.C.	
221	C57	N.C.	
222	C50	N.C.	
223	C59	N.C.	
224	C51	1000uF	Cond. el. ver. 25V p. 2.5mm
225	C60	1000uF	Cond. el. ver. 25V p. 2.5mm
226	R103	680	Res. 1/4 W 1%
227	R104	680	Res. 1/4 W 1%
228	C1	100pF	Cond. ceramico p. 5mm
229	R6	604H0	Res. 1/4 W 1%
230	R4	604H0	Res. 1/4 W 1%
231	JP7	STM03S	Strip M 2.54 3 pin.
232	JP8	STM03S	Strip M 2.54 3 pin.
233	JP5	STM03S	Strip M 2.54 3 pin.
234	JP6	STM03S	Strip M 2.54 3 pin.

235	R58	10K0	Res. 1/4 W 1%
236	R59	10K0	Res. 1/4 W 1%
237	R56	10K0	Res. 1/4 W 1%
238	R57	10K0	Res. 1/4 W 1%
239	R70	1K0	Res. 1/4 W 1%
240	R60	1K0	Res. 1/4 W 1%
241	R105	10K0	Res. 1/4 W 1%
242	R106	10K0	Res. 1/4 W 1%
243	R107	10K0	Res. 1/4 W 1%
244	R108	10K0	Res. 1/4 W 1%
245	R109	10K0	Res. 1/4 W 1%
246	R110	10K0	Res. 1/4 W 1%
247	CN2	BNC_IS90	Conn. BNC is. da cs a 90°
248	CN1	BNC_IS90	Conn. BNC is. da cs a 90°
249	CN5	BNC_IS90	Conn. BNC is. da cs a 90°
250	JP2	STM03S	Strip M 2.54 3 pin.
251	JP3	STM03S	Strip M 2.54 3 pin.
252	CN7	XLRFC5	Conn. XLR F. da CS 90°
253	CN6	XLRFC5	Conn. XLR F. da CS 90°
254	CN4	BNC_IS90	Conn. BNC is. da cs a 90°
255	CN3	BNC_IS90	Conn. BNC is. da cs a 90°
256	R111	10K0	Res. 1/4 W 1%
257	R112	10K0	Res. 1/4 W 1%
258	JP22	STM03S	Strip M 2.54 3 pin.
259	JP23	N.C.	
260	JP24	N.C.	
261	JP25	STM03S	Strip M 2.54 3 pin.
262	R79	49K9	Res. 1/4 W 1%
263	R81	4K99	Res. 1/4 W 1%
264	R44	4K99	Res. 1/4 W 1%
265	RV6	20K	Trim. mult. 3296X rg H
266	RV5	20K	Trim. mult. 3296X rg H
267	JP10	STM03S	Strip M 2.54 3 pin.
268	JP9	STM03S	Strip M 2.54 3 pin.
269	RV7	20K	Trim. mult. 3296X rg H
270	RV9	10K	Trim. mult. 3296W rg V
271	RV8	10K	Trim. mult. 3296W rg V
272	RV10	10K	Trim. mult. 3296W rg V
273	RV11	10K	Trim. mult. 3296W rg V
274	JP11	STM03S	Strip M 2.54 3 pin.
275	R51	10K0	Res. 1/4 W 1%
276	RV2	50K	Trim. mult. 3296X rg H
277	RV1	50K	Trim. mult. 3296X rg H
278	JP15	STF26D	Strip F 2x2.54 26 pin.
279	JP12	STF16D	Strip F 2x2.54 16 pin.
280	JP17	STF16D	Strip F 2x2.54 16 pin.
281	C105	100uF	Cond. el. ver. 25V p. 2.5mm
282	RV4	10K	Trim. mult. 3296X rg H
283	RV3	10K	Trim. mult. 3296X rg H
284	JP18	STM03S	Strip M 2.54 3 pin.
285	JP19	STM03S	Strip M 2.54 3 pin.
286	JP20	STM03S	Strip M 2.54 3 pin.
287	JP21	STM03S	Strip M 2.54 3 pin.
288	JP14	CN20PD	Conn. M cs 2x2.54mm a 20 pin.
289	JP16	CN26PD	Conn. M cs 2x2.54mm a 26 pin.
290	D19	LED-G3	Led Verde dia. 3mm
291	D20	LED-G3	Led Verde dia. 3mm
292	L12	2.2uH	Impedenza
293	L11P	2.2uH	Impedenza
294	L10	2.2uH	Impedenza

295	L9	2.2uH	Impedenza
296	L8	2.2uH	Impedenza
297	L7	2.2uH	Impedenza
298	L6	2.2uH	Impedenza
299	L5	2.2uH	Impedenza
300	L4	2.2uH	Impedenza
301	L3	2.2uH	Impedenza
302	L2	2.2uH	Impedenza
303	L1	2.2uH	Impedenza
304	L16	2.2uH	Impedenza
305	L15	0	Res.
306	L14	2.2uH	Impedenza
307	L13	0	Res.
308	R31	1M0	Res. 1/4 W 1%
309	R28	1M0	Res. 1/4 W 1%
310	R35	1M0	Res. 1/4 W 1%
311	R32	1M0	Res. 1/4 W 1%
312	R47	1M0	Res. 1/4 W 1%
313	R48	1M0	Res. 1/4 W 1%
314	R46	1M0	Res. 1/4 W 1%
315	R45	N.C.	
316	C46	470nF	Cond. ceramico p. 5mm
317	C47	470nF	Cond. ceramico p. 5mm
318	C45	470nF	Cond. ceramico p. 5mm
319	C43	470nF	Cond. ceramico p. 5mm
320	C44	470nF	Cond. ceramico p. 5mm
321	C42	470nF	Cond. ceramico p. 5mm

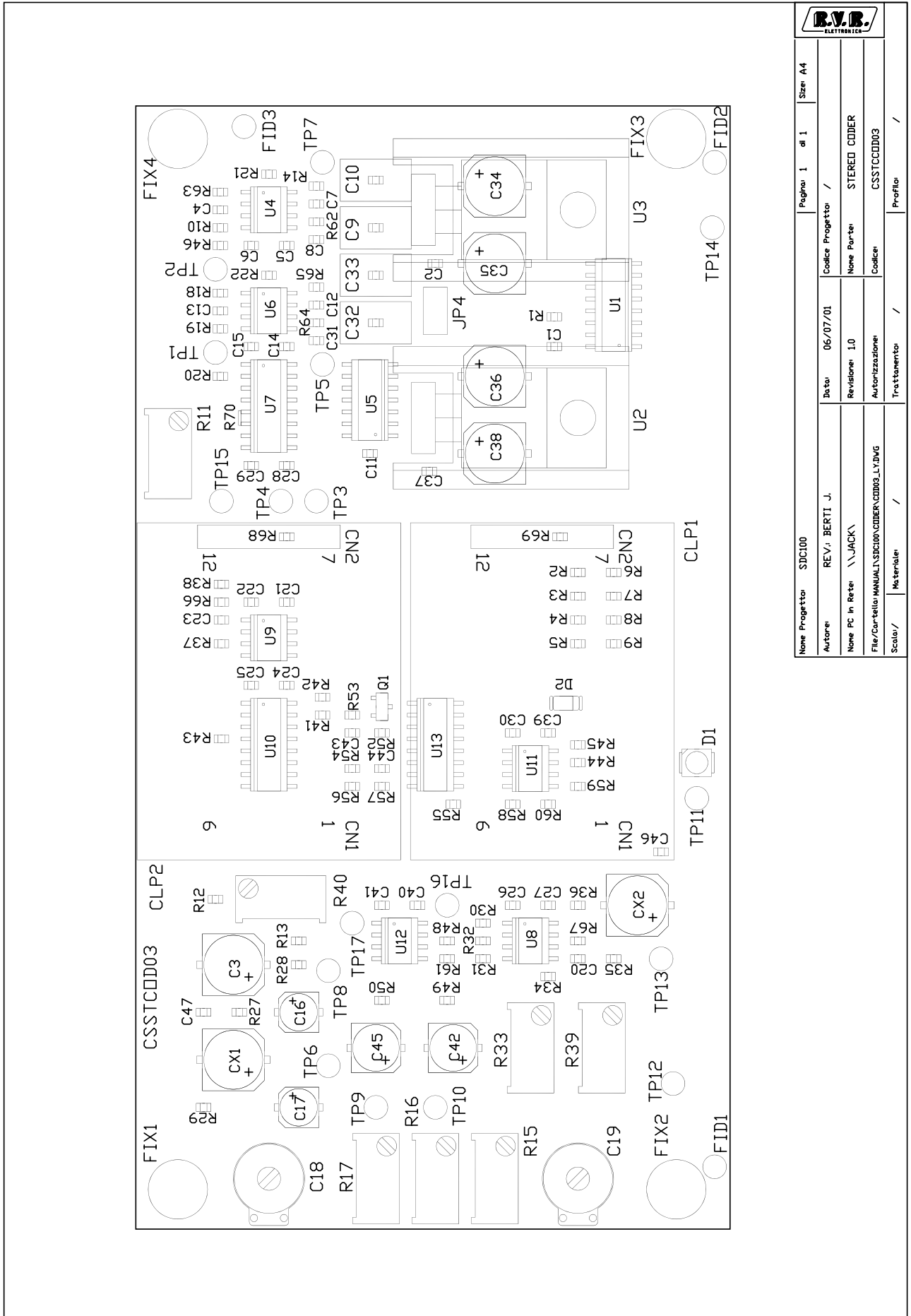

Nome Progetto: SDC100		Pagina: 1 di 1		Size: A4	
Autore: REV.1 BERTI J.	Codice Progetto: /				
Nome PC in Rete: \JACK	Revisione: 1.0		STEREO CODDER		
File/Carrello: MANUAL\SDC100\CODER\CDD03_L1.DWG	Autorizzazione: /		CSSTCOD03		
Scala: /	Materiale: /		Trattamento: /		
				Profilo: /	

R.V.R.	
Nome Progetto: SDC100	Revisione: 1.1
Autore: M.MARZ	Disegnato/Verificato: /
Nome Scheda: STEREO CODER	Revisione: 1.1
Indirizzo: Viale P. di S. Maria Maddalena	Abilitazione: /
Indirizzo: Viale P. di S. Maria Maddalena, 100 - 00187 Roma	Contatto: 06/57550000

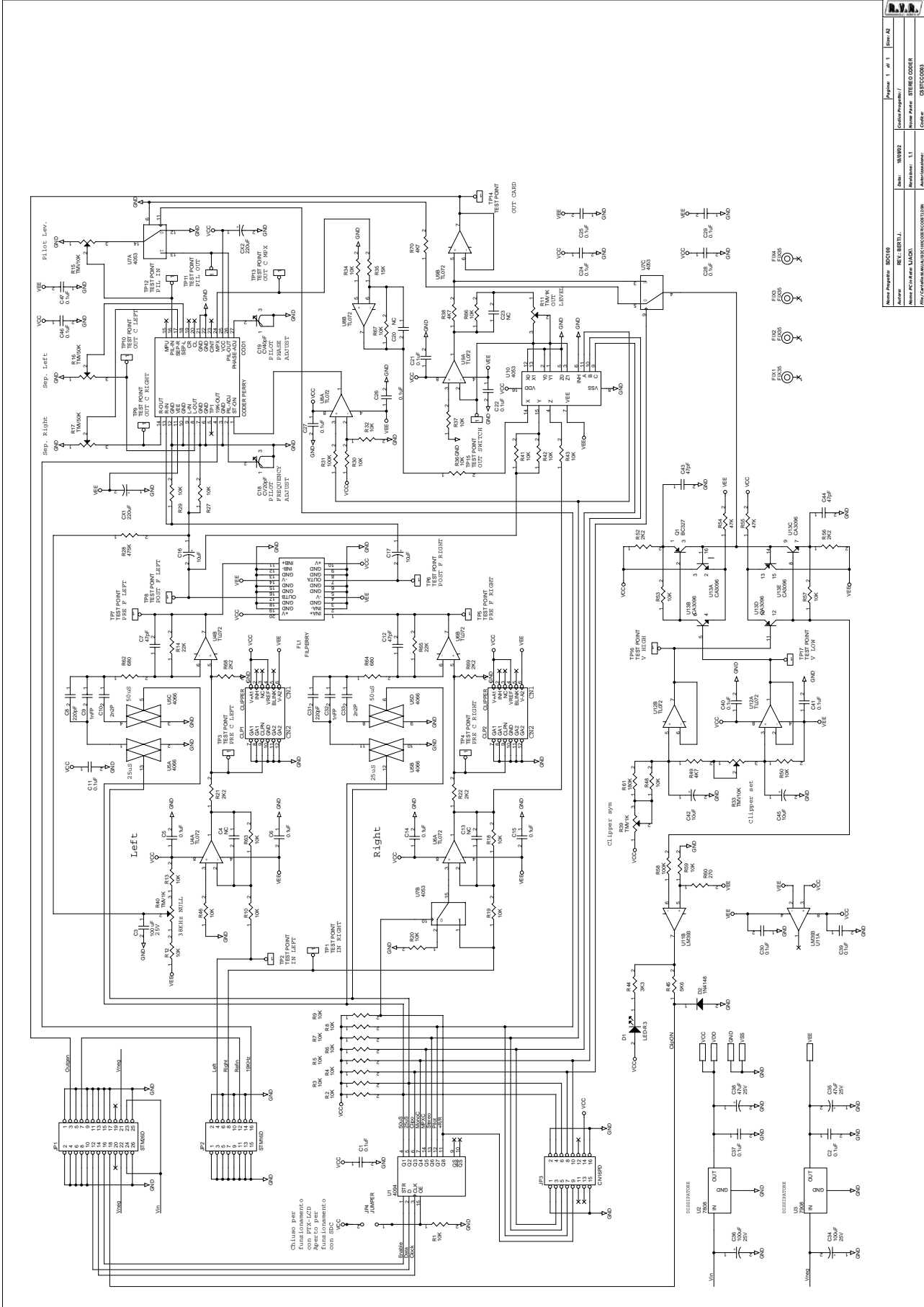

SLPTCODSTE03		Bill Of Materials	Page1
Item	Quantity	Reference	Part
1	2	CLP1	CLIPPER
		CLP2	CLIPPER
2	1	COD1	CODER PERRY
3	2	CX1	220uF
		CX2	220uF
4	22	C1	0.1uF
		C2	0.1uF
		C5	0.1uF
		C6	0.1uF
		C11	0.1uF
		C14	0.1uF
		C15	0.1uF
		C21	0.1uF
		C22	0.1uF
		C24	0.1uF
		C25	0.1uF
		C26	0.1uF
		C27	0.1uF
		C28	0.1uF
		C29	0.1uF
		C30	0.1uF
		C37	0.1uF
C39	0.1uF		
C40	0.1uF		
C41	0.1uF		
C46	0.1uF		
C47	0.1uF		
5	1	C3	100 uF
6	4	C7	47pF
		C12	47pF
		C43	47pF
		C44	47pF
7	2	C8	220pF
		C31	220pF
8	2	C9	1nFP
		C32	1nFP
9	2	C10	2n2P
		C33	2n2P
10	4	C16	10uF
		C17	10uF
		C42	10uF
		C45	10uF
11	1	C18	CV20pF
12	1	C19	CV40pF
13	2	C4	NC
		C13	NC
		C20	NC
		C23	NC
14	2	C36	100uF
		C34	100uF
15	2	C38	47uF
		C35	47uF
16	1	D1	LED-R3
17	1	D2	1N4148

18	4	FIX1	FIX35
		FIX2	FIX35
		FIX3	FIX35
		FIX4	FIX35
19	1	FL1	FILPERRY
20	1	JP1	STM26D
21	1	JP2	STM16D
22	1	JP3	CN16PD
23	1	Q1	BC327
24	34	R1	10K
		R2	10K
		R3	10K
		R4	10K
		R5	10K
		R6	10K
		R7	10K
		R8	10K
		R9	10K
		R10	10K
		R12	10K
		R13	10K
		R18	10K
		R19	10K
		R20	10K
		R27	10K
		R29	10K
		R30	10K
		R32	10K
		R34	10K
		R36	10K
		R37	10K
		R41	10K
		R42	10K
		R43	10K
		R46	10K
		R48	10K
		R50	10K
		R53	10K
		R57	10K
		R59	10K
		R63	10K
		R66	10K
		R67	10K
25	3	R11	TMV1K
		R39	TMV1K
		R40	TMV1K
26	2	R14	22K
		R65	22K
27	2	R15	TMV10K
		R33	TMV10K
28	2	R17	TMV50K
		R16	TMV50K
29	4	R21	2K2
		R22	2K2
		R52	2K2
		R56	2K2
		R68	2K2
		R69	2K2
30	1	R28	475K
31	2	R31	100K

		R58	100K
32	1	R35	15K
33	2	R49	4K7
		R38	4K7
		R70	4K7
34	1	R44	3K3
35	1	R45	5K6
36	2	R54	47K
		R55	47K
37	1	R60	270
38	1	R61	180K
39	2	R62	680
		R64	680
40	1	U1	4094
41	1	U2	7808
42	5	U4	TL072
		U6	TL072
		U8	TL072
		U9	TL072
		U12	TL072
43	1	U5	4066
44	2	U7	4053
		U10	4053
45	1	U11	LM393
46	1	U13	CA3096

Pagina lasciata intenzionalmente in bianco
This page intentionally left blank

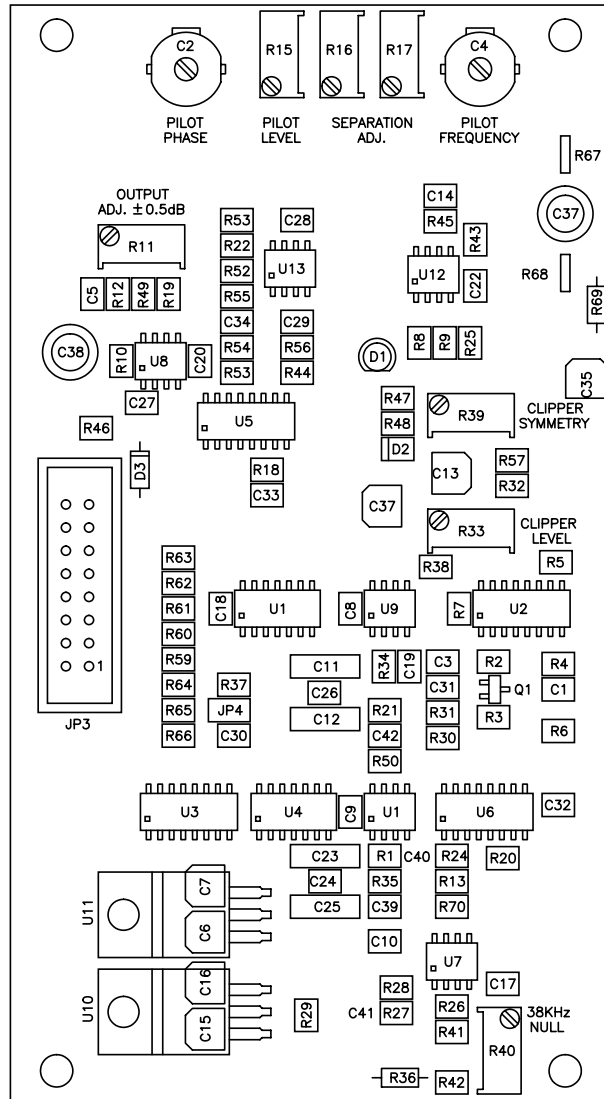

None Progettato		SDC100		Pagina 1 di 1		Size A3	
Autore		D'Alessio D.		Codice Progettato /			
None PC in Rete		\\JACK\		Data 20/03/97		None Parter-STERED CODER COMPONENT LAYOUT	
File/Car-tella		MANUAL\SDC100\CODER\LAYSTCDB.DWG		Revisione 1.0		Codice SLP1STCODSTE02	
Scala /		Masterlar /		Autorizzazione /		Profilo /	

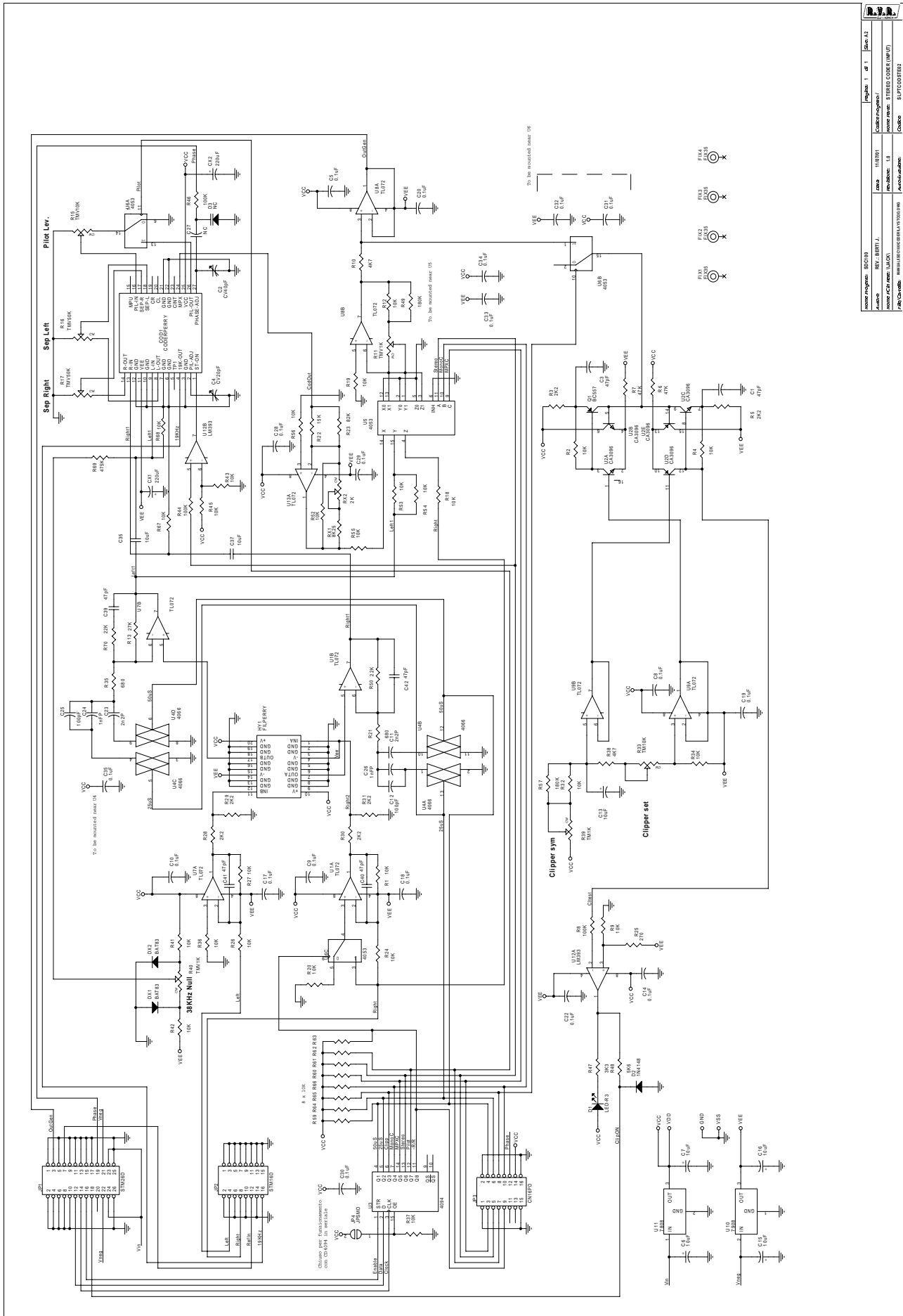

Nome progetto:	SDC100	pagina:	1	di:	1	Scale:	A2
Autore:	REV. BRUNO J.	Controllato:					
Nome file:	SDC100 (IMP.UT)	Versione:					
File:	SDC100 (IMP.UT)	Autore:					
File:	SDC100 (IMP.UT)	Autore:					

SLPTCODSTE02 Bill Of Materials Page1

Item	Quantity	Reference	Part
1	1	COD1	CODERPERRY
2	2	CX2,CX1	220uF
3	6	C1,C3,C39,C40,C41,C42	47pF
4	1	C2	CV40pF
5	1	C4	CV20pF
6	18	C5,C8,C9,C10,C14,C17,C18, C19,C20,C22,C28,C29,C30, C31,C32,C33,C34,C35	0.1uF
7	7	C6,C7,C13,C15,C16,C35, C37	10uF
8	2	C11,C23	2n2P
9	2	C12,C25	100pF
10	2	C24,C26	1nFP
11	2	D3,C27	NC
12	2	DX1,DX2	BAT83
13	1	D1	LED-R3
14	1	D2	1N4148
15	4	FIX1,FIX2,FIX3,FIX4	FIX35
16	1	HY1	FILPERRY
17	1	JP1	STM26D
18	1	JP2	STM16D
19	1	JP3	CN16PD
20	1	JP4	JPSMD
21	1	Q1	BC557
22	1	RX1	8K25
23	1	RX2	2K
24	33	R1,R2,R4,R9,R12,R18,R19, R20,R24,R26,R27,R32,R34, R36,R37,R41,R42,R43,R45, R52,R53,R54,R55,R56,R59, R60,R61,R62,R63,R64,R65, R66,R67	10K
25	6	R3,R5,R28,R29,R30,R31	2K2
26	2	R6,R7	47K
27	3	R8,R44,R46	100K
28	2	R10,R38	4K7
29	2	R11,R40	TMV1K
30	1	R13	27K
31	1	R15	TMV10K
32	2	R16,R17	TMV50K
33	2	R21,R35	680
34	1	R22	15K
35	1	R23	82K
36	1	R25	270
37	1	R33	TM10K
38	1	R39	TM1K
39	1	R47	3K3
40	1	R48	5K6
41	2	R49,R57	180K
42	1	R50	22K
43	1	R69	475K
44	5	U1,U7,U8,U9,U13	TL072
45	1	U2	CA3096
46	1	U3	4094
47	1	U4	4066

48	2	U5, U6	4053
49	1	U10	7908
50	1	U11	7808
51	1	U12	LM393
52	1	R68	10K
53	1	R70	22K

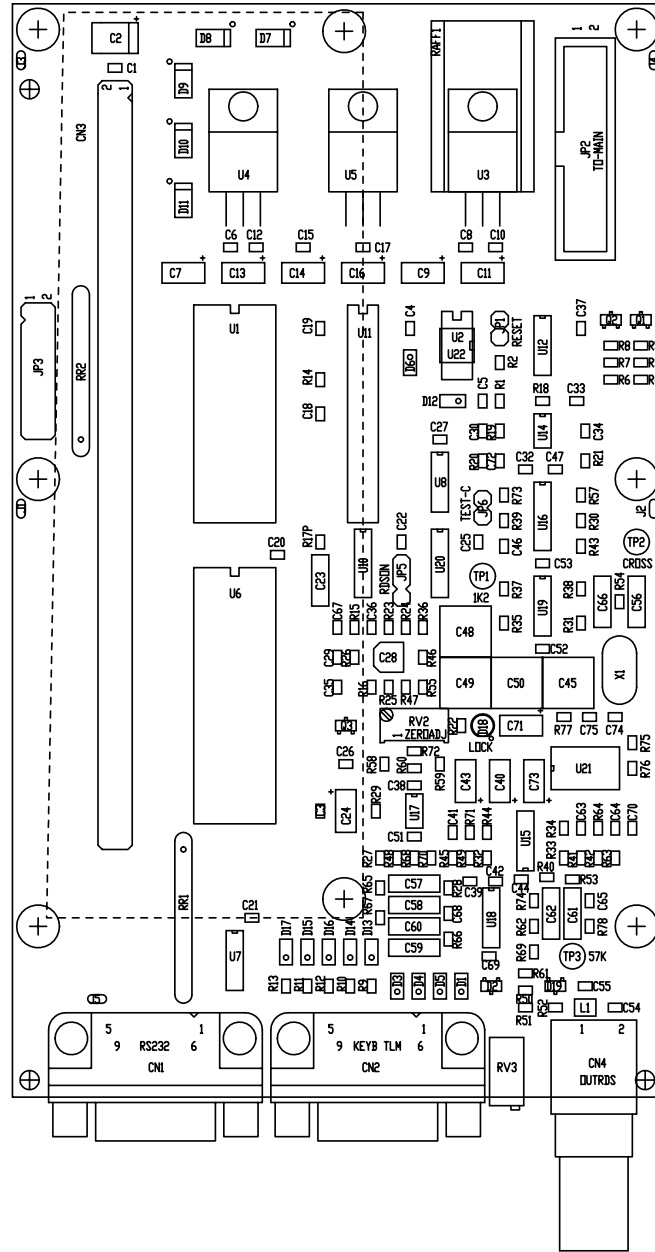

		Pagina: 1	di 1	Size: A4
Nome Progetto	SDC100	Data	09/10/01	Nome Parte
Autore	REV.: BERTI J.	Revisione	1.1	SCHEDA CODER RDS
Nome PC in Rete	\\JACK\	Autore		CSSDCRDS003
File/Contatto	MANUAL\SDC100\RDS\CSSDCRDS003.DWG	Trattamenti	/	Profilo
Scala	/			

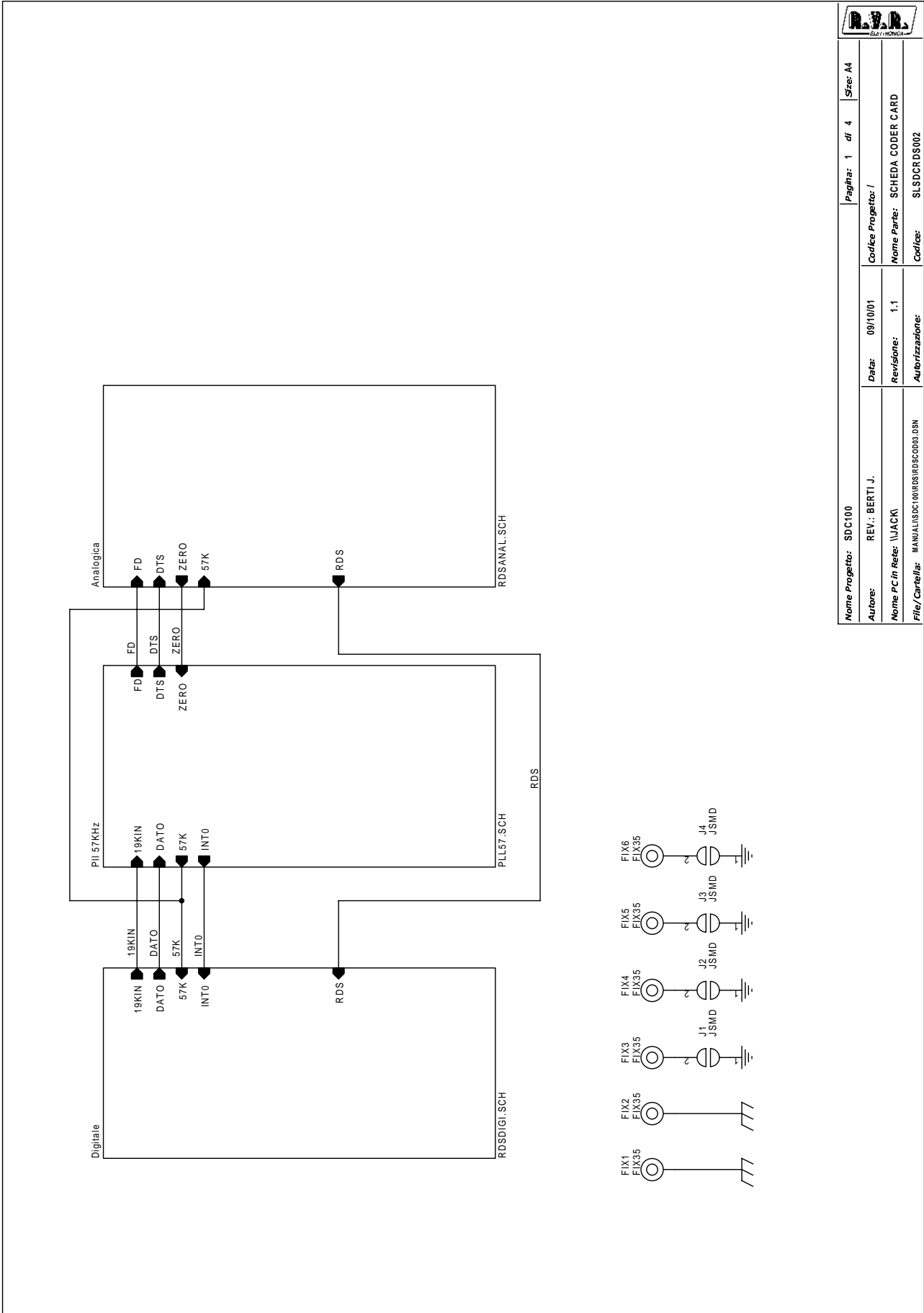

Nome Progetto: SDC100		Pagina: 1	di 4	Size: A4
Autore: REV.: BERTI J.	Data: 09/10/01	Codice Progetto: /		
Nome P.C in Rete: \JACKI	Revisione: 1.1	Nome Parte: SCHEDA CODER CARD		
File/ Cartella: MANUALESDC100RDSRSC000.DSN	AutORIZZAZIONE:	Codice: SLSDCRDS002		

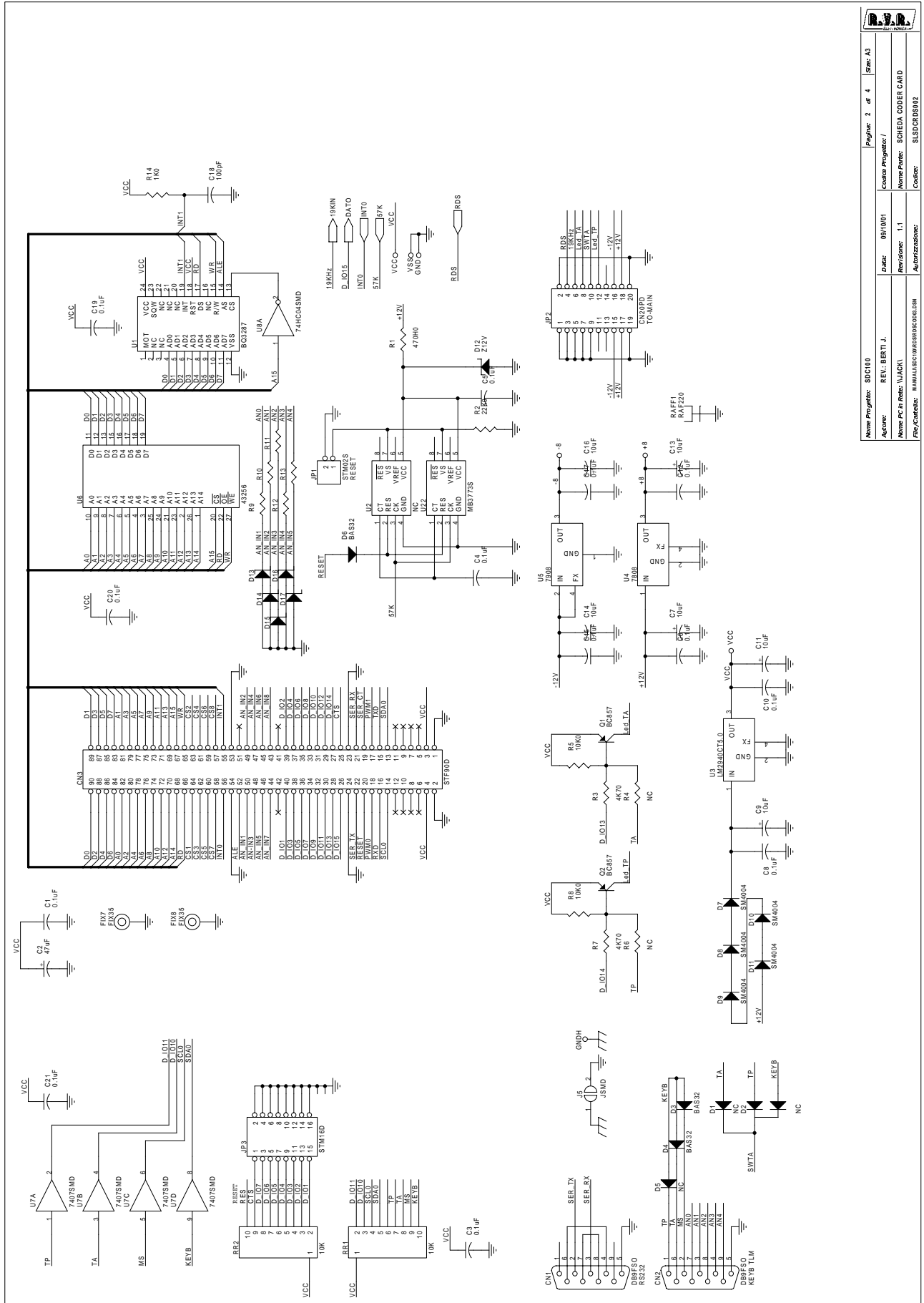

Nome Progetto:	SDC100	Page:	2 of 4	Size:	A3
Autore:	REV: BERTI J.	Data:	09/10/01	Nome Progetto:	
Nome PC o Rete:	UJACKA	Revisione:	1.1	Nome Parte:	SCHEMA CODER CARD
File/Controlli:	MANUALI/SCHEMI/SDC100.DSN	Autore:		Nome:	SJSDCRDS002

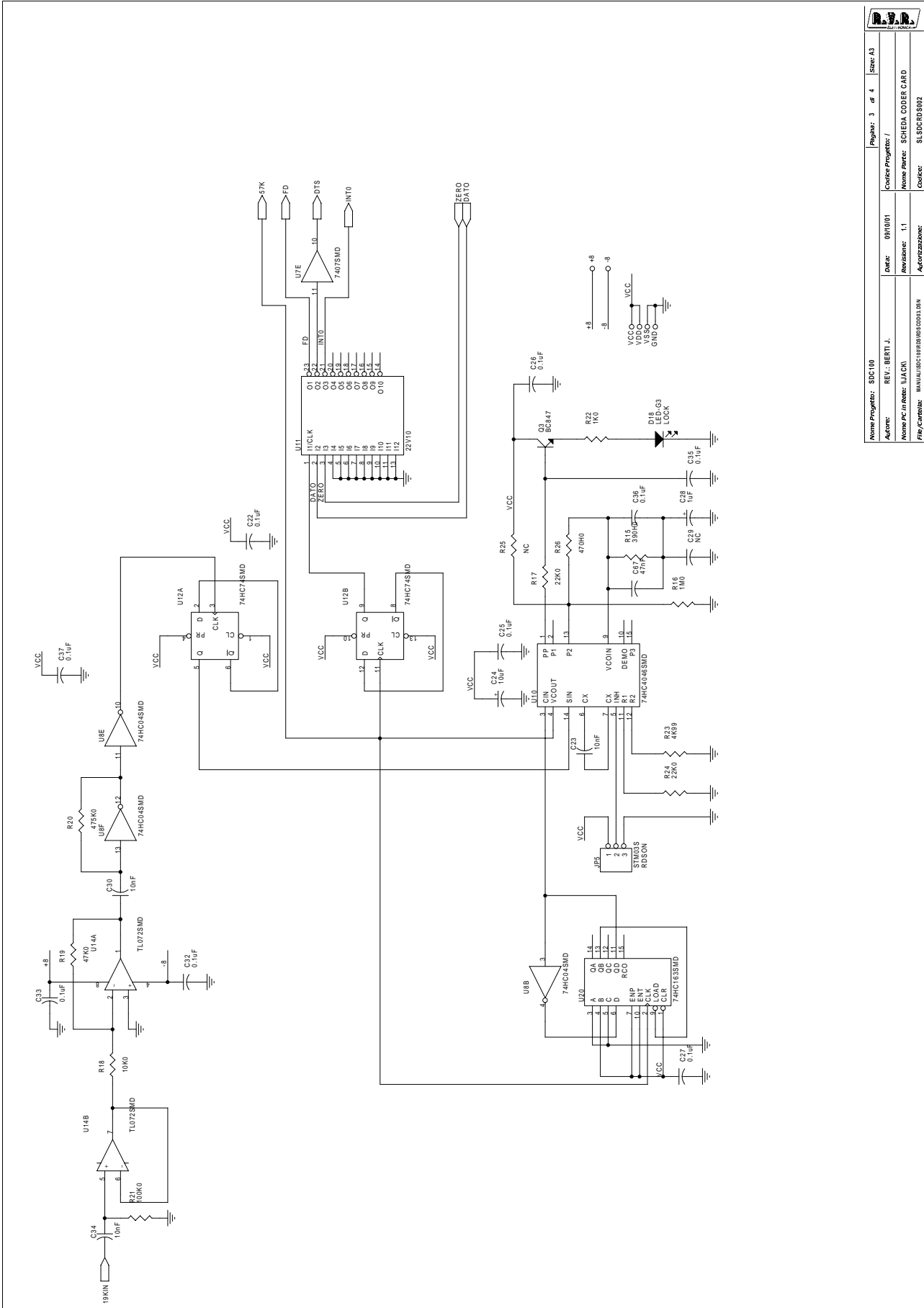

		Pagina: 3 di 4	Size: A3
Nome Progetto: SDC100	Rev.: BERTI J.	Data: 09/10/01	Codice Progetto: /
Autore:	Nome PC / Rev: UACX1	Revisione: 1.1	Nome Part: SCHEDA CODER CARD
File / Cartelle:	M:\UACX1\SDC100\SDC100.DSN	Autorizzazione:	Codice: S1.SDCRDS02

Item	Quantity	Reference	Part
1	2	CN1, CN2	DB9FSO
2	1	CN3	STF90D
3	1	CN4	BNC_IS90
4	35	C1, C3, C4, C5, C6, C8, C10, C12, C15, C17, C19, C20, C21, C22, C25, C26, C27, C32, C33, C35, C36, C37, C38, C39, C41, C42, C44, C46, C47, C51, C52, C53, C68, C69, C72	0.1uF
5	1	C2	47uF
6	11	C7, C9, C11, C13, C14, C16, C24, C40, C43, C71, C73	10uF
7	1	C18	100pF
8	4	C23, C30, C34, C66	10nF
9	1	C28	1uF
10	9	D1, U2, D2, R4, D5, R6, R25, C29, R75	NC
11	5	C45, C48, C49, C50, C67	47nF
12	2	C55, C54	27pF
13	1	C56	470nF
14	7	C57, C58, C59, C60, C61, C62, C65	1.5nF
15	1	C63	1nF
16	1	C64	330pF
17	1	C70	560pF
18	1	C74	47pF
19	1	C75	82pF
20	3	D3, D4, D6	BAS32
21	5	D7, D8, D9, D10, D11	SM4004
22	1	D12	Z12V
23	5	D13, D14, D15, D16, D17	Z5V1
24	1	D18	LED-G3
25	1	D19	BAV99
26	8	FIX1, FIX2, FIX3, FIX4, FIX5, FIX6, FIX7, FIX8	FIX35
27	2	JP1, JP6	STM02S
28	1	JP2	CN20PD
29	1	JP3	STM16D
30	1	JP5	STM03S
31	5	J1, J2, J3, J4, J5	JSMD
32	1	L1	2.2uH
33	2	Q1, Q2	BC857
34	1	Q3	BC847
35	1	RAFF1	RAF220
36	2	RR1, RR2	10K
37	1	RV2	5K
38	14	RV3, R5, R8, R18, R28, R30, R31, R38, R39, R54, R58, R62, R66, R69	10K0
39	2	R1, R26	470H0
40	3	R2, R17, R24	22K0
41	2	R7, R3	4K70
42	13	R9, R10, R11, R12, R13, R14, R22, R33, R40, R41, R44, R45, R49	1K0

43	1	R15	390H0
44	2	R16,R60	1M0
45	2	R19,R36	47K0
46	1	R20	475K0
47	3	R21,R29,R57	100K0
48	1	R23	4K99
49	2	R27,R65	18K2
50	2	R32,R34	3K90
51	2	R37,R35	80K6
52	1	R42	6K80
53	4	R43,R72,R76,R77	2K20
54	3	R46,R47,R71	100H0
55	2	R48,R70	332H0
56	1	R50	0
57	3	R51,R52,R74	22H0
58	2	R53,R68	4K75
59	1	R55	20K0
60	1	R59	14K7
61	1	R61	4K99
62	1	R63	2K0
63	1	R64	11K0
64	1	R73	47H0
65	1	R78	8K25
66	3	TP1,TP2,TP3	TP1
67	1	U1	BQ3287
68	1	U3	LM2940CT5.0
69	1	U4	7808
70	1	U5	7908
71	1	U6	43256
72	1	U7	7407SMD
73	1	U8	74HC04SMD
74	1	U10	74HC4046SMD
75	1	U11	22V10
76	1	U12	74HC74SMD
77	1	U14	TL072SMD
78	1	U15	1496SMD
79	1	U16	4053SMD
80	1	U17	LM311SMD
81	2	U18,U19	TL074SMD
82	1	U20	74HC163SMD
83	1	U21	SAA6579S
84	1	U22	MB3773S
85	1	X1	Q8M664
86	1	R67	31K6

Pagina lasciata intenzionalmente in bianco
This page was intentionally left blank

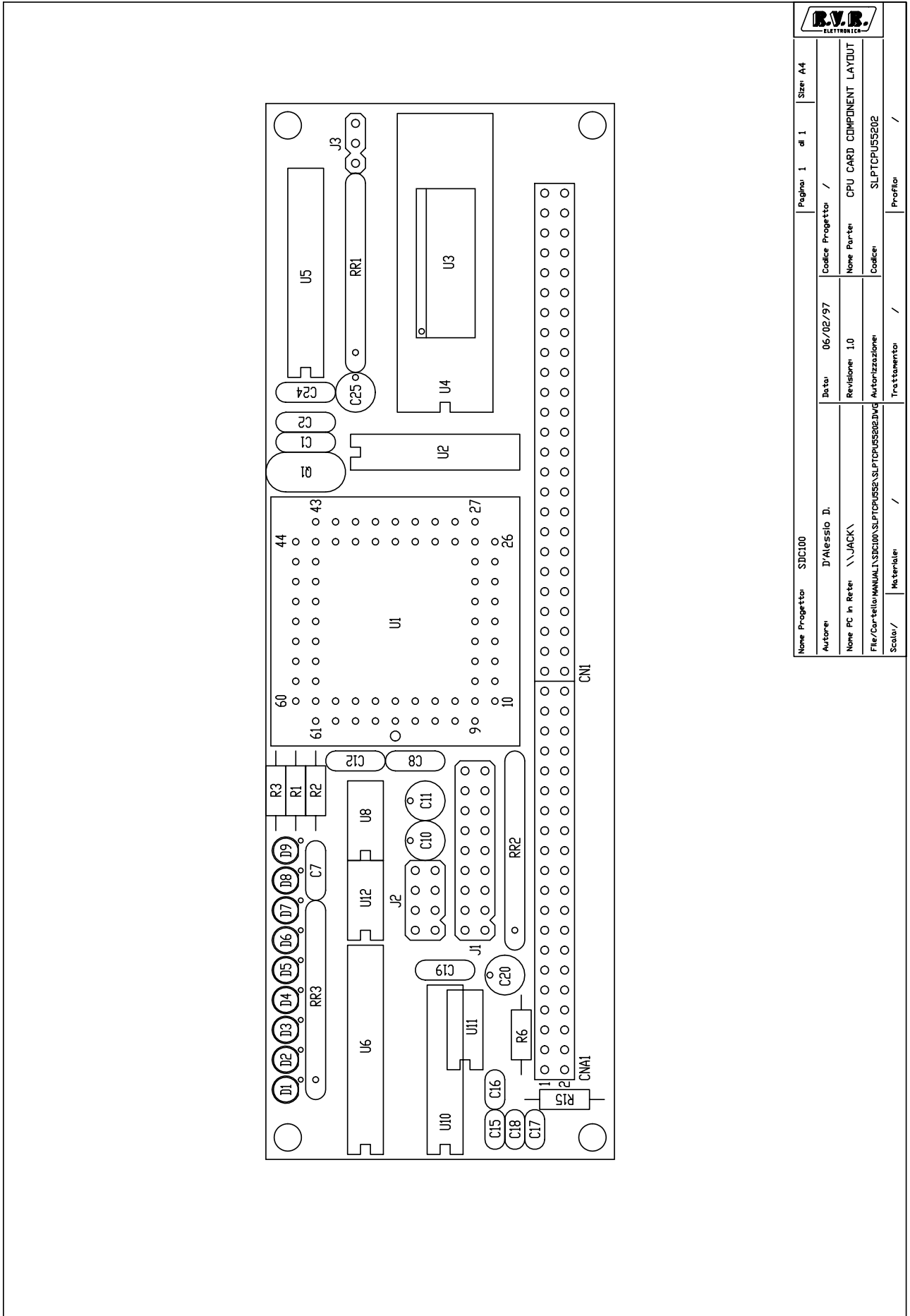

		Pagina 1	di 1	Size: A4
Nome Progetto:	SDC100	Data:	06/02/97	Codice Progetto: /
Autore:	D'Alessio D.	Revisione:	1.0	Nome Parte: CPU CARD COMPONENT LAYOUT
None PC In Rete:	\\JACK	Autore:	SLPTCPU55202	Codice: SLPTCPU55202
File/Cartella:	MANUAL\SDC100\SLPTCPU55202.DWG	Trattamento:	/	Profilo: /
Scala:	/			

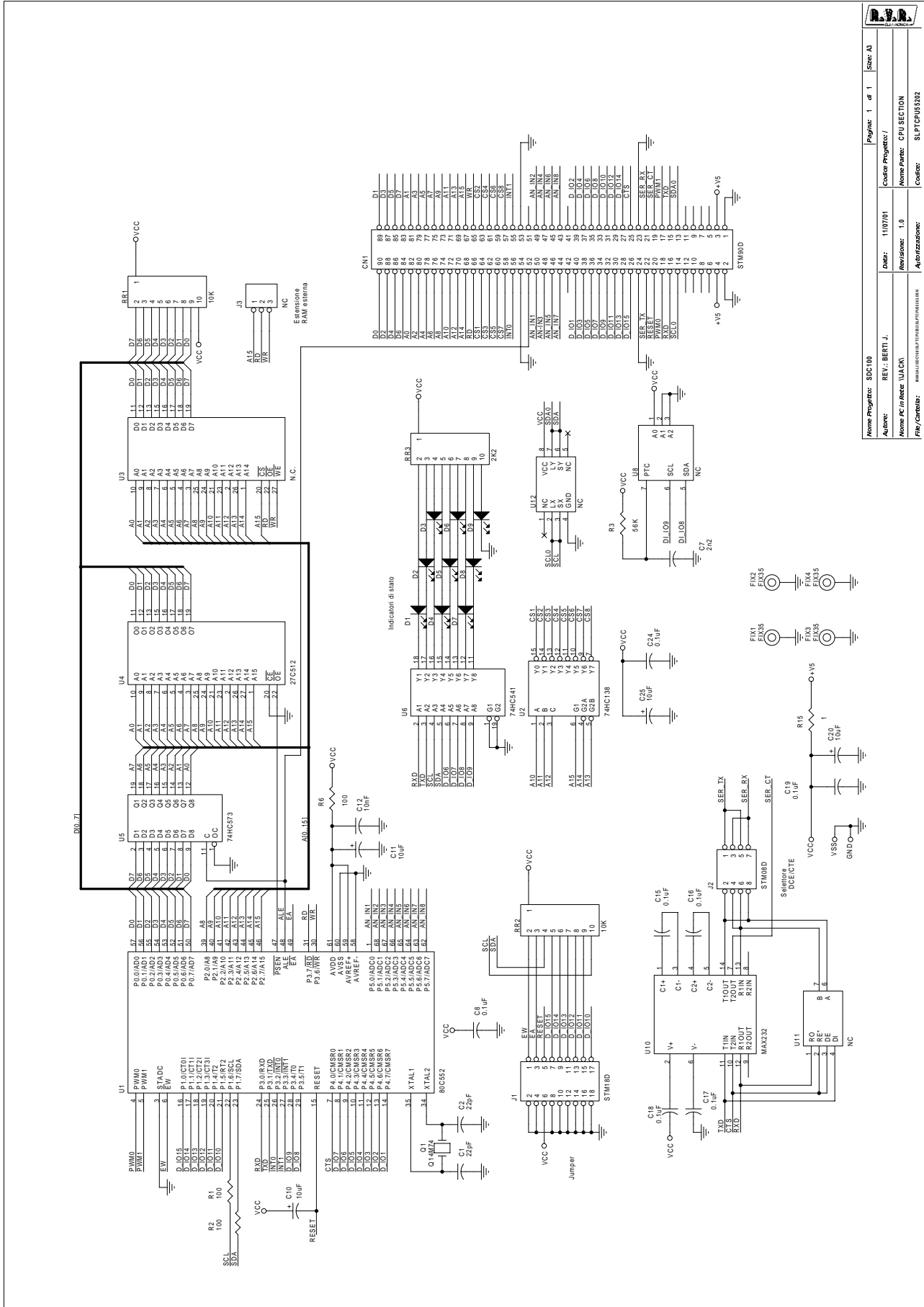

Nome Progetto:	SDC100	Page:	1 of 1	Scale:	A3
Autore:	REV.: BERTI J.	Data:	11/07/01	Nome Progetto:	
Autore PC in Rete:	U.A.C.K.I.	Revisione:	1.0	Nome Parte:	CPU SECTION
File/Caricatore:		Autore:		Nome:	SLPTCPU5202

SLPTCPU55202 Bill Of Materials Page1

ItemQuantity Reference Part

1	1	CN1	STM90D
2	2	C1 ,C2	22pF
3	1	C7	2n2
4	7	C8 ,C15 ,C16 ,C17 ,C18 ,C19 , C24	0.1uF
5	4	C10 ,C11 ,C20 ,C25	10uF
6	1	C12	10nF
7	9	D1 ,D2 ,D3 ,D4 ,D5 ,D6 ,D7 ,D8 , D9	LED-R3
8	4	FIX1 , FIX2 , FIX3 , FIX4	FIX35
9	1	J1	STM18D
10	1	J2	STM08D
11	2	U11 ,J3	NC
12	1	Q1	Q14M74
13	2	RR2 ,RR1	10K
14	1	RR3	2K2
15	3	R1 ,R2 ,R6	100
16	1	R3	56K
17	1	R15	1
18	1	U1	80C552
19	1	U2	74HC138
20	1	U3	NC
21	1	U4	27C512
22	1	U5	74HC573
23	1	U6	74HC541
24	1	U8	NC
25	1	U10	MAX232
26	1	U12	NC

Pagina lasciata intenzionalmente in bianco
This page was intentionally left blank