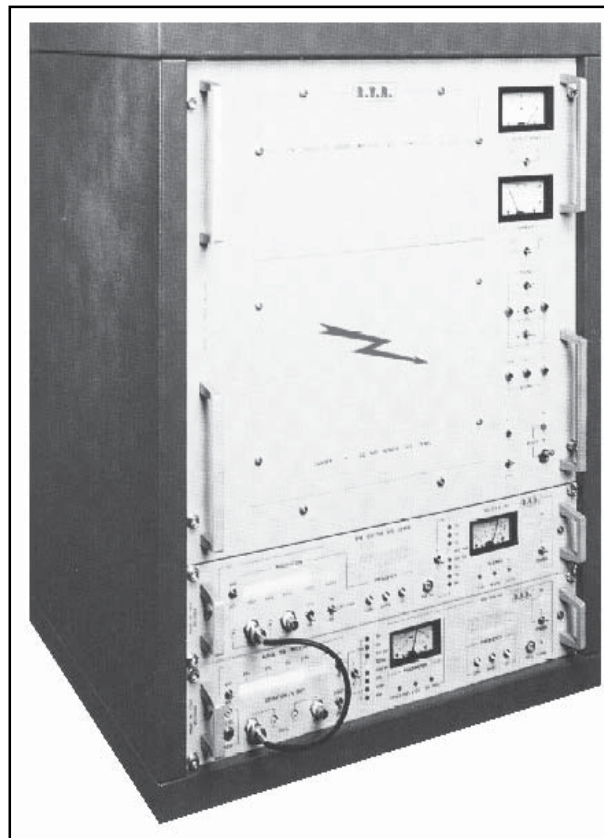

VJ1000HP



User Manual

Prodotto da



Italia



VJ1000HP - USER MANUAL
Version 4.0

© Copyright 1993-2001
R.V.R. Elettronica SpA
Via del Fonditore 2/2c - 40138 - Bologna (Italia)
Telefono: +39 051 6010506
Fax: +39 051 6011104
Email: info@rvr.it
Web: www.rvr.it

All rights reserved

Printed and bound in Italy. No part of this manual may be reproduced, memorized or transmitted in any form or by any means, electronic or mechanic, including photocopying, recording or by any information storage and retrieval system, without the permission of the copyright owner.



Notification of intended purpose and limitations of product use

This product is a FM transmitter intended for FM audio broadcasting. It utilises operating frequencies not harmonised in the intended countries of use.

The user must obtain a license before using the product in intended country of use. Ensure respective country licensing requirements are complied with.

Limitations of use can apply in respect of operating frequency, transmitter power and/or channel spacing.

Declaration of Conformity

Hereby, R.V.R. Elettronica SpA, declares that this FM transmitter is in compliance with the essential requirements and other relevant provisions of Directive 1999/5/EC.



This page intentionally left blank

Table of Content

1. Preliminary instructions	1
2. Warranty	2
3. First Aid	4
3.1 Treatment of electrical shocks	4
3.1.1 If victim is not responsive	4
3.1.2 If victim is responsive	5
3.2 Treatment of electrical Burns	5
3.2.1 Extensive burned and broken skin	5
3.2.2 Less severe burns (1st and 2nd degree)	5
4. General Description	6
4.1 Mechanical Description	6
4.2 Electrical Description	6
4.3 Controls and Indicators	6
4.4 Protection System	7
4.5 Specifications	7
5. Electrical Description	10
5.1 Introduction	10
5.2 Power Supply	10
5.3 Protection Card	10
5.4 Tube	10
6. Installation Procedure	24
6.1 Introduction	24
6.2 Unpacking	24
6.3 Fitting the Tube	24
6.4 Connection and Setup Procedures	24
6.5 Fault Finding during the Setup Procedure	26
7. Maintenance Procedure	28
7.1 Safety Procedures	28
7.2 Routine Maintenance	28
7.3 Replacement of Components	28
7.4 Replacement of the Tube	29
7.5 Changing the Air Filter	29
8. Calibration Procedure	30
8.1 Frequency Changes	30
8.2 Calibration of the Protection Card	31
8.3 Calibration of the PWR Meter (REF)	32
8.4 Calibration of the PWR Meter (FWD)	32
8.5 Calibration of the Grid Current Meter (IG)	33
8.6 Calibration of Anode Measurement (IA)	33
9. Connectors Description	37

9.1	Telemetry Connector	37
10.	Telemetry Card Option	38
10.1	Calibration of the Voltages on the Telemetry connector	38
10.2	Wiring Connections details	38
10.3	General Verifications	39
Appendix		40

1. Preliminary instructions

This manual is written as a general guide for those having previous knowledge and experience with this kind of equipment.

It is not intended to contain a complete statement of all safety rules which should be observed by personnel in using this or other electronic equipment.

The installation, use and maintenance of this piece of equipment involve risks both for the personnel performing them and for the device itself, that shall be used only by trained personnel.

R.V.R. doesn't assume responsibility for injury or damage resulting from improper procedures or practices by untrained/unqualified personnel in the handling of this unit.

Please observe all local codes and fire protection standards in the operations of this unit.



WARNING: always disconnect power before opening covers or removing any part of this unit.

Use appropriate grounding procedures to short out capacitors and high voltage points before servicing.



WARNING: This is a "CLASS A" equipment. In a residential place this equipment can cause hash. In this case can be requested to user to take the necessary measures.

R.V.R. Elettronica SpA reserves the right to modify the design and/or the technical specifications of the product and this manual without notice.

2. Warranty

Any product of **R.V.R. Elettronica** is covered by a 12 (twelve) month warranty.

For components like tubes for power amplifiers, the original manufacturer's warranty applies.

R.V.R. extends to the original end-user purchaser all original manufacturers warranties which are transferable and all claims are to be made directly to R.V.R. per indicated procedures.

R.V.R.'s warranty shall not include:

- 1) Re-shipment of the unit to R.V.R. for repair purposes
- 2) Any unauthorized repair/modification
- 3) Incidental/consequential damages as a result of any defect
- 4) Nominal non-incidentals defects
- 5) Re-shipment costs or insurance of the unit or replacement units/parts

Warranty shall come into force from invoice date and for the period of the manufacturer's warranty.

Any damage to the goods must be reported to the carrier in writing on the shipment receipt.

Any discrepancy or damage discovered subsequent to delivery, shall be reported to R.V.R. within five (5) days from its receipt.

To claim your rights under this warranty:

- a. Contact the dealer or distributor where you purchased the unit. Describe the problem and ask if he has an easy solution. Dealers and Distributors are supplied with all the information about problems that may occur and usually they can repair the unit quicker than what the manufacturer could do. Very often installing errors are discovered by dealers.
- b. If your dealer cannot help you, contact R.V.R. in Bologna and explain the problem. If it is decided to return the unit to the factory, R.V.R. will mail you a regular authorization with all the necessary instructions to send back the goods.
- c. When you receive the authorization, you can return the unit. Pack it carefully for the shipment, preferably using the original packing and seal the package perfectly. The customer always assumes the risks of loss (i.e., R.V.R. is never responsible for damage or loss), until the package reaches R.V.R. premises. For this reason, we suggest you to insure the goods for the whole value. Shipment must be effected C.I.F. (PREPAID) to the address specified by R.V.R.'s service manager on the authorization.



DO NOT RETURN UNITS WITHOUT OUR AUTHORIZATION AS THEY WILL BE REFUSED.

- a Be sure to enclose a written technical report where mention all the problems found and a copy of your original invoice establishing the starting date of the warranty.

Replacement and warranty parts may be order from the following address. Be sure to include the equipment model and serial number as well as part description and part number.

R.V.R. Elettronica SpA
Via del Fonditore, 2/2c
40138 BOLOGNA
ITALY
Tel. +39 051 6010506

3. First Aid

The personnel employed in the installation, use and maintenance of the device, shall be familiar with theory and practice of first aid.

3.1 Treatment of electrical shocks

3.1.1 If victim is not responsive

follow the A-B-C's of basic life support

- Place victim flat on his back on a hard surface.
- Open airway: lift up neck, push forehead back
- clear out mouth if necessary and observe for breathing
- if not breathing, begin artificial breathing (Figure 2): tilt head, pinch nostrils, make airtight seal, four quick full breaths. Remember mouth to mouth resuscitation must be commenced as soon as possible

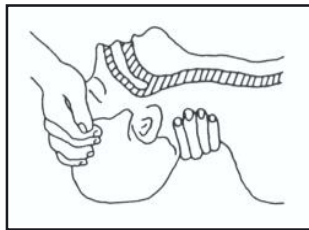


Figure 1



Figure 2

- Check carotid pulse (**Figura 3**); if pulse is absent, begin artificial circulation(**Figura 4**) depressing sternum 1 1/2" TO 2" (**Figure 5**).

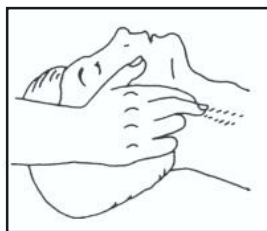


Figura 3

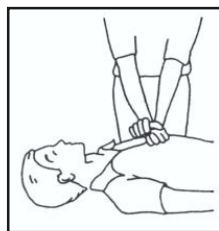


Figura 4

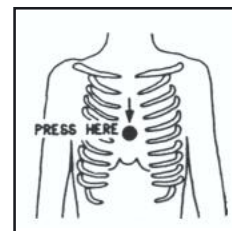


Figure 5

- APPROX. 80 SEC. : ONE RESCUER, 15 COMPRESSIONS
- APPROX. 60 SEC.: TWO RESCUERS, 5 COMPRESSIONS, 1 BREATH
- DO NOT INTERRUPT RHYTHM OF COMPRESSIONS WHEN SECOND PERSON IS GIVING BREATH
- Call for medical assistance as soon as possible.

3.1.2 If victim is responsive

- Keep them warm
- Keep them as quiet as possible
- Loosen their clothing (a reclining position is recommended)
- Call for medical help as soon as possible

3.2 Treatment of electrical Burns

3.2.1 Extensive burned and broken skin

- Cover area with clean sheet or cloth (Cleansed available cloth article).
- Do not break blisters, remove tissue, remove adhered particles of clothing, or apply any salve or ointment.
- Treat victim for shock as required.
- Arrange transportation to a hospital as quickly as possible.
- If arms or legs are affected keep them elevated

If medical help will not be available within an hour and the victim is conscious and not vomiting, give him a weak solution of salt and soda: 1 level teaspoonful of salt and 1/2 level teaspoonful of baking soda to each quart of water (neither hot or cold). Allow victim to sip slowly about 4 ounces (half a glass) over a period of 15 minutes. Discontinue fluid if vomiting occurs



Do not give alcohol

3.2.2 Less severe burns (1st and 2nd degree)

- Apply cool (not ice cold) compresses using the cleansed available cloth article.
- Do not break blisters, remove tissue, remove adhered particles of clothing, or apply salve or ointment.
- Apply clean dry dressing if necessary.
- Treat victim for shock as required.
- Arrange transportation to a hospital as quickly as possible
- If arms or legs are affected keep them elevated.

4. General Description

4.1 Mechanical Description

The VJ1000HP is housed in a 19" rack-mountable frame, 14U high, of which 4U are free and may be used for an exciter, a receiver or other equipment.

All controls and switches are situated on the front panel together with two analog meters.

There are no connectors on the rear panel.

Both the cooling air inlet complete with fan and filter, and the power cable entry hole may be found on this panel.

A flue may be found on the top of the unit for the expulsion of hot air used for cooling the unit, together with the RF output connector (to be connected to the antenna).

4.2 Electrical Description

The VJ1000HP is a tube amplifier with an earthed grid allowing a wide-band input (no calibration across the band) from 87.5 to 108MHz.

This amplifier is able to generate an output power of over 1KW from an input power of approx. 25W.

The amplifier features motorized anode and load matching across the entire operational band.

The VJ1000HP is available in single phase version.

4.3 Controls and Indicators

Two analog meters are present on the front panel; one measures direct power output and reflected power output (1 Fig.1), the other measures plate and grid currents (3 Fig.1).

The output power meter has only one scale 1KW f.s., both for the measurement of the direct power output and for reflected power output.

The meter for the measurements of the grid and plate currents has two scales too; one for 1A f.s. for the measurement of the grid current and for 100mA for the grid current.

For each of these meters there are the relative reading selector

(2 and 4 Fig.1).

In central position there are some switches and led indicators that concern to the plate and load tuning: the two led indicators signal respectively the stop for the plate tuning at 87.5 MHz (6 Fig.1) and at 108 MHz (8 Fig.1), while the three selectors are used respectively for to enable the engines of tuning (5 Fig.1), for the plate tuning (7 Fig.1) and for the load tuning (9 Fig.1).

Then there are three led indicators that signal alarms: for an excess of R.O.S. (10 Fig.1), for insufficient fan pressure (11 Fig.1) and for an excess of grid current (12 Fig.1).

The following are present on the front panel: an HT indicator which signals that the high voltage supply is active; a switch to activate the HT supply, or put the unit in stand-by (ST.BY. 15 Fig.1); an on-off switch and corresponding indicator (14 and 16 Fig.1).

4.4 Protection System

The VJ1000HP features protection against: excess VSWR, excess grid current, opening of panels with the unit active, and insufficient ventilation.

Under abnormal conditions the unit will be automatically deactivated; after 90 seconds the protection system will re-activate the unit if the condition has returned to normal, unless a panel is still open or the cooling system lacks sufficient pressure.

In this event, the procedure is repeated four times, after which the unit will remain deactivated for 15 minutes.

If, after 15 minutes, the condition is still present, four more switch-on attempts are made, after which the unit is shut down indefinitely.

Should, during these cycles, the fault condition disappear and the protection system succeed in re-activating the unit for more than 15 minutes, the fault condition counter will be reset to zero.

N.B. The times indicated above are approximate and may vary considerably.

4.5 Specifications

Please refer to Table A for the electrical specification and Table B for the mechanical specification.

TABLE A**ELECTRICAL SPECIFICATIONS**

Power Supply	Single Phase: 220-240 V, 50-60 Hz
Frequency Range	87,5 - 108 MHz (others on request)
Output Power	850 - 1100 W
RF Output Impedance	50 Ohm
Output Connector	"LC" connector, 7/8" o 7/16"
RF Input Impedance	50 Ohm
Input Connector	"N" type connector
RF Input Power	20 W typical, max 25 W
Tube	EIMAC 3CX1500 A7 (8877)
Cooling System	Forced ventilation
Harmonic and Spurious Signal Soppression	Meets or exceeds FCC and CCIR regulations

TABLE B**DIMENSIONAL AND ENVIRONMENTAL SPECIFICATIONS**

Rack Dimensions	540mm(21,26")W 540mm(21,26)D 698,3mm(27,49")H
Panel Dimensions	483mm(19)W 443mm(17,44")H
Weight	65 Kg
Operating Temperature Range	da -10 a +45°C
Maximum Humidity	max 90%, senza condensa

5. Electrical Description

5.1 Introduction

This section describes in detail, the operation of the VJ1000HP.

For ease of description, the unit has been divided into sections, each of which is described in detail, below.

5.2 Power Supply

The power supply, accessible via the rear panel, has been designed to be both rugged and at the same time simple to maintain, allowing easy access to every component thus easing repair work.

The power supply features a PI filter after the rectifying stage which attenuates spurious components.

Two fuses provide overload protection.

The power supply comprises two separate transformers: the largest supplies the tube anode, the other transformer supplies the tube's filament and supplies various functions such as relays and the protection system.

This power supply is designed to work at single phase voltages.

5.3 Protection Card

This card is mounted in a metal box and fixed to the right-hand side of the RF chamber's chassis (6 Photo 2). This sub-unit has three alarm inputs which carry the signal to a comparator which compares them to a pre-defined threshold. Should one of these inputs exceed the alarm threshold, the amplifier is deactivated and a counter is started.

If the fault condition does not disappear within the period defined by the counter, the unit is shut down indefinitely.

5.4 Tube

The ceramic/metal power triode 3CX1500A7/8877 has been designed to work in AB₂ class amplifiers, in class B cathode-driven amplifiers, in audio or RF applications including the VHF band, or in class C cathode-driven, anode-modulated RF amplifiers.

As linear amplifiers, they feature high power gain with low levels of intermodulation.

For the tube specification, see table C.

TABLE C

TUBE SPECIFICATIONS

Model:	3CX1500A7/8877	
Anode Dissipation:	1500W approx.	
Grid dissipation:	25W approx.	
Max Frequency:	250 MHz	
Cooling System:	Forced ventilation	
Filament Voltage:	5V	
Filament Current:	10.5A	
Capacitance with Grounded Cathode	Input:	38.5 pF
	Output:	0.1 pF
	Input/Output:	10.2 pF
Capacitance with Grounded Grid	Input:	38.5 pF
	Output:	10.2 pF
	Input/Output:	0.1 pF
Amplification Factor:	200	
Transconductance:	55.000 μ mhos	
Recommended Socket for Gounded		
Grid operation:	SK2210	
Recommended Socket for Grounded		
Cathode operation:	SK2200	
Recommended flue:	SK2216	
Maximum Anode and Solder Temperature	250°C	
Maximum Length:	102.2 mm (4.02")	

Maximum Diameter:	85.8 mm (3.38")
Weight:	0.7 Kg (1.6 lbs)
Operational Position:	Any

FRONT PANEL'S VIEW DESCRIPTION (FIG. 1)

1	OUTPUT POWER	Analog meter for the measurement of direct and reflected output power
2	DIR/REF	Switch for the selection of direct or reflected power measurement
3	CURRENTS	Analog meter for the measurement of anode and grid currents
4	GRID/PLATE	Switch for the selection of grid or anode current measurement
5	TUNING	Motorized tuning switch
6	LED "-" (87,5)	LED to indicate that tuning has reached end of range at 87.5 MHZ. OFF signifies end of range
7	PLATE	Anode tuning switch
8	LED "+" (108)	LED to indicate that tuning has reached end of range at 108 MHZ. OFF signifies end of range
9	LOAD	Load matching switch
10	V.S.W.R.	Indicator showing excess V.S.W.R.
11	PRESS.	Indicator showing insufficient fan pressure
12	I.G.	Alarm indicator for excess grid current
13	H.T.	Indicator showing high voltage active
14	ON	Power indicator
15	ST.BY.	Standby switch
16	POWER	Power ON/OFF switch
17	PANNELLO H.T.	Internal access to RF chamber
18	RESTART	Alarm reset (only in the version with telemetry option)
19	ALARMS CARD ON	Alarms card on (only in the version with telemetry option)

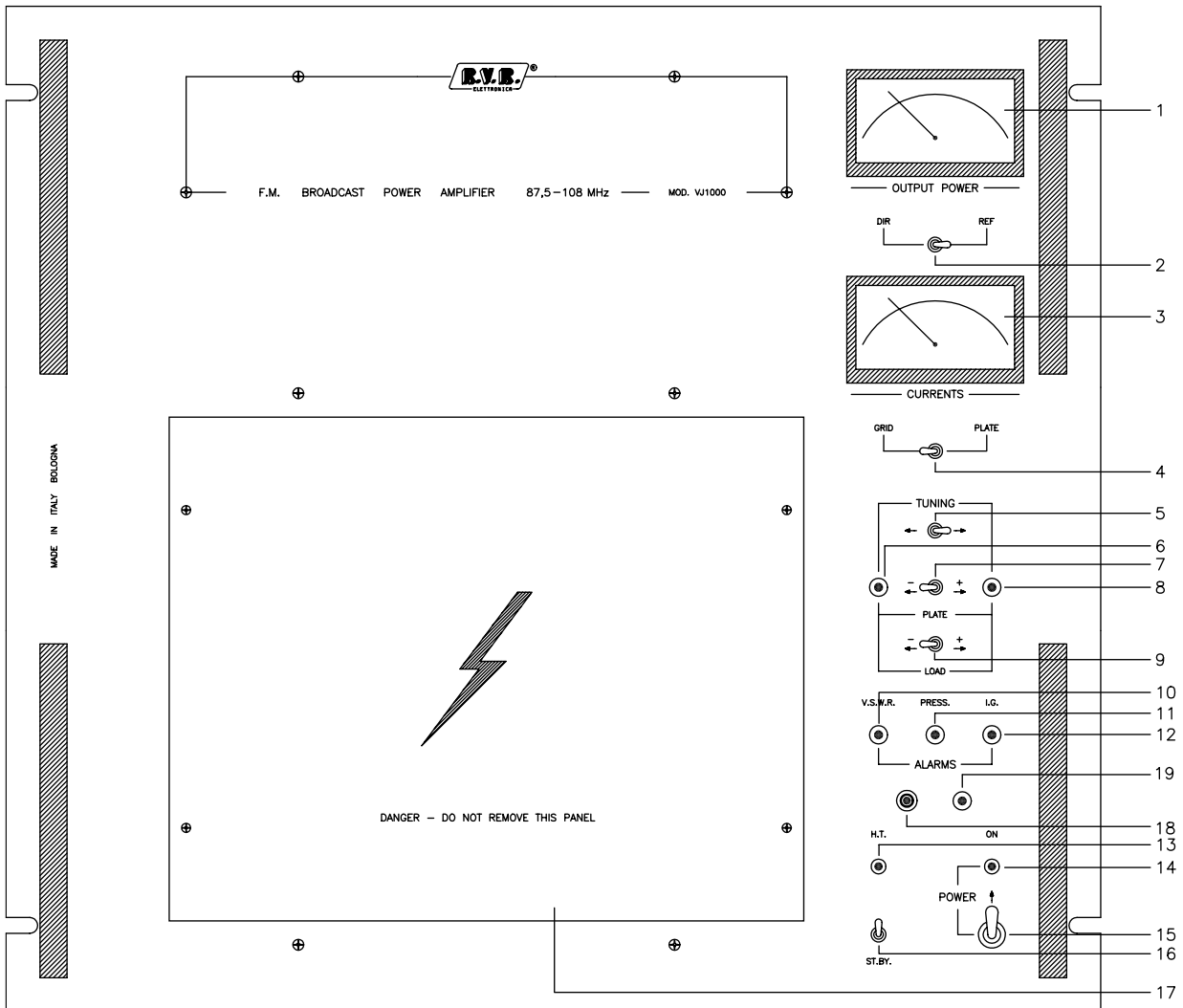


FIG. 1

POWER SUPPLY'S VIEW DESCRIPTION (FIG. 2)

- 1 Auxiliary and filament transformer
- 2 Anode supply filter capacitor
- 3 High voltage rectifier board
- 4 Anode supply transformer
- 5 High voltage resistor
- 6 High voltage resistor
- 7 Anode delay timer
- 8 Solenoid switch
- 9 Line fuse holders
- 10 Line power connector
- 11 Exciter supply
- 12 Earth

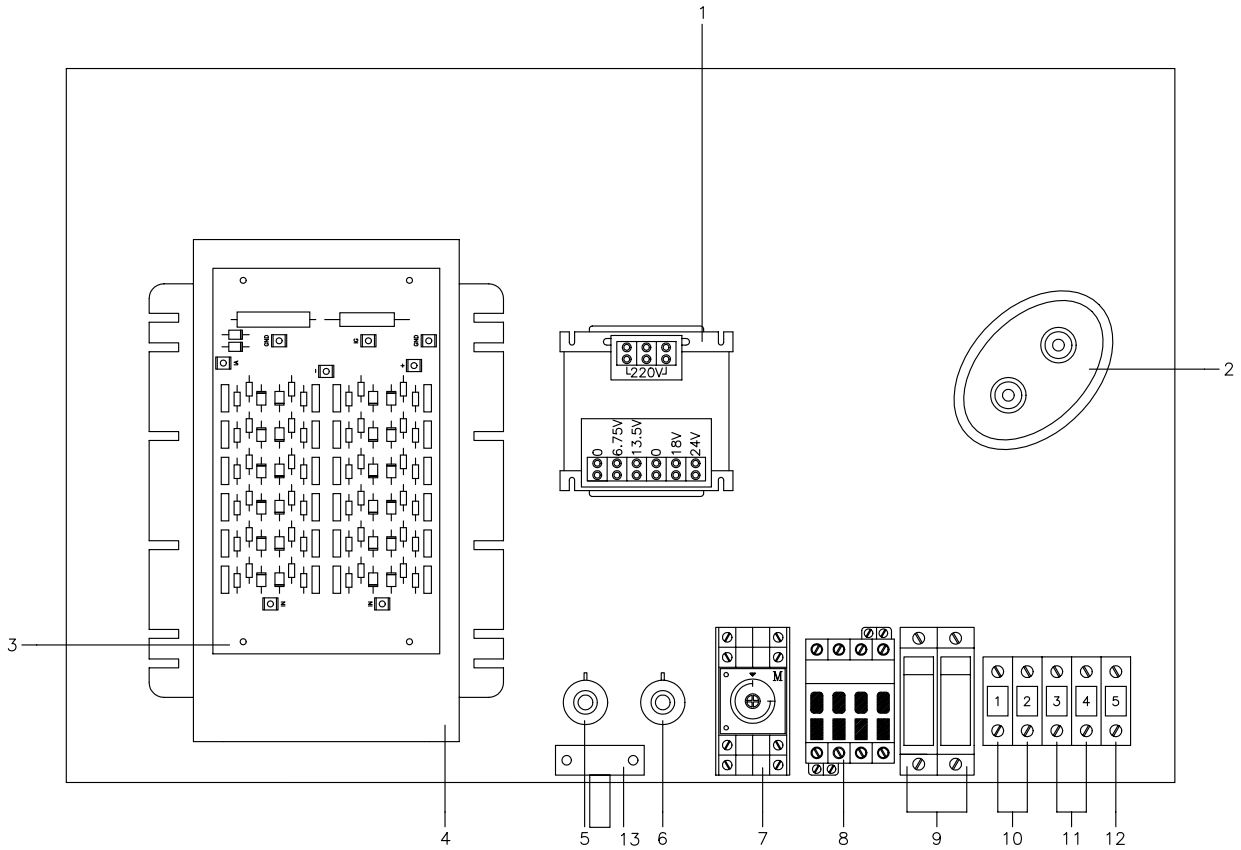


FIG. 2

R.F. CAVITY'S VIEW DESCRIPTION (PHOTO 1)

- 1 Cooling air outlet
- 2 Plate tuning control motor
- 3 Output connector (to antenna)
- 4 End of tuning range switch (87,5MHz)
- 5 Directional coupler for output power measurement
- 6 Line
- 7 Tube
- 8 End of tuning range switch (108Mhz)
- 9 Low pass filter
- 10 Teflon C capacitor
- 11 High voltage input connector
- 12 Load matching capacitor CV
- 13 Micro Switch

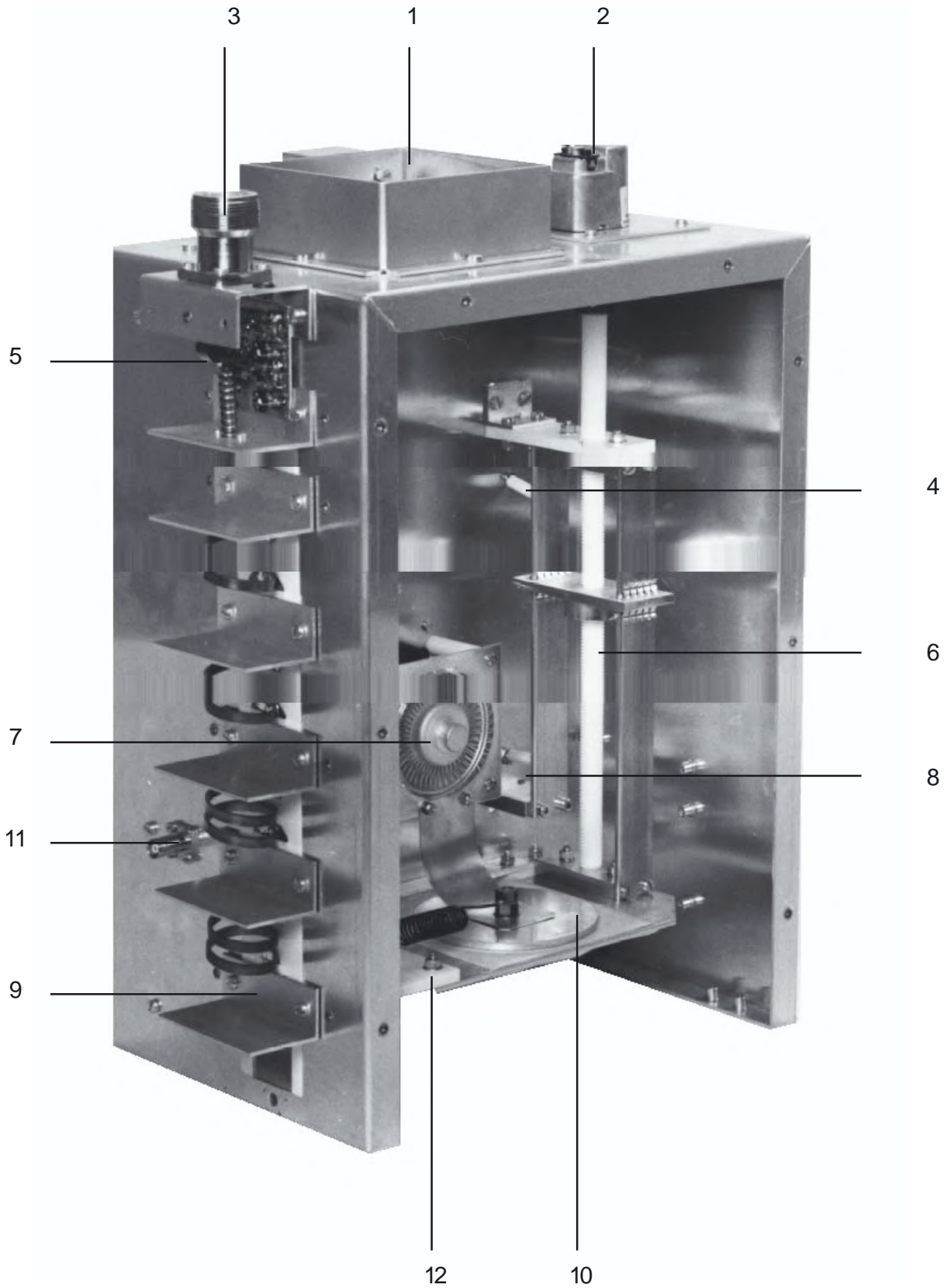


PHOTO 1

R.F. BLOCK'S VIE DESCRIPTION (PHOTO 2)

- 1 Plate tuning control motor
- 2 Cooling air outlet
- 3 Air flow switch
- 4 Input connector (to exciter)
- 5 Air blower
- 6 Alarms card

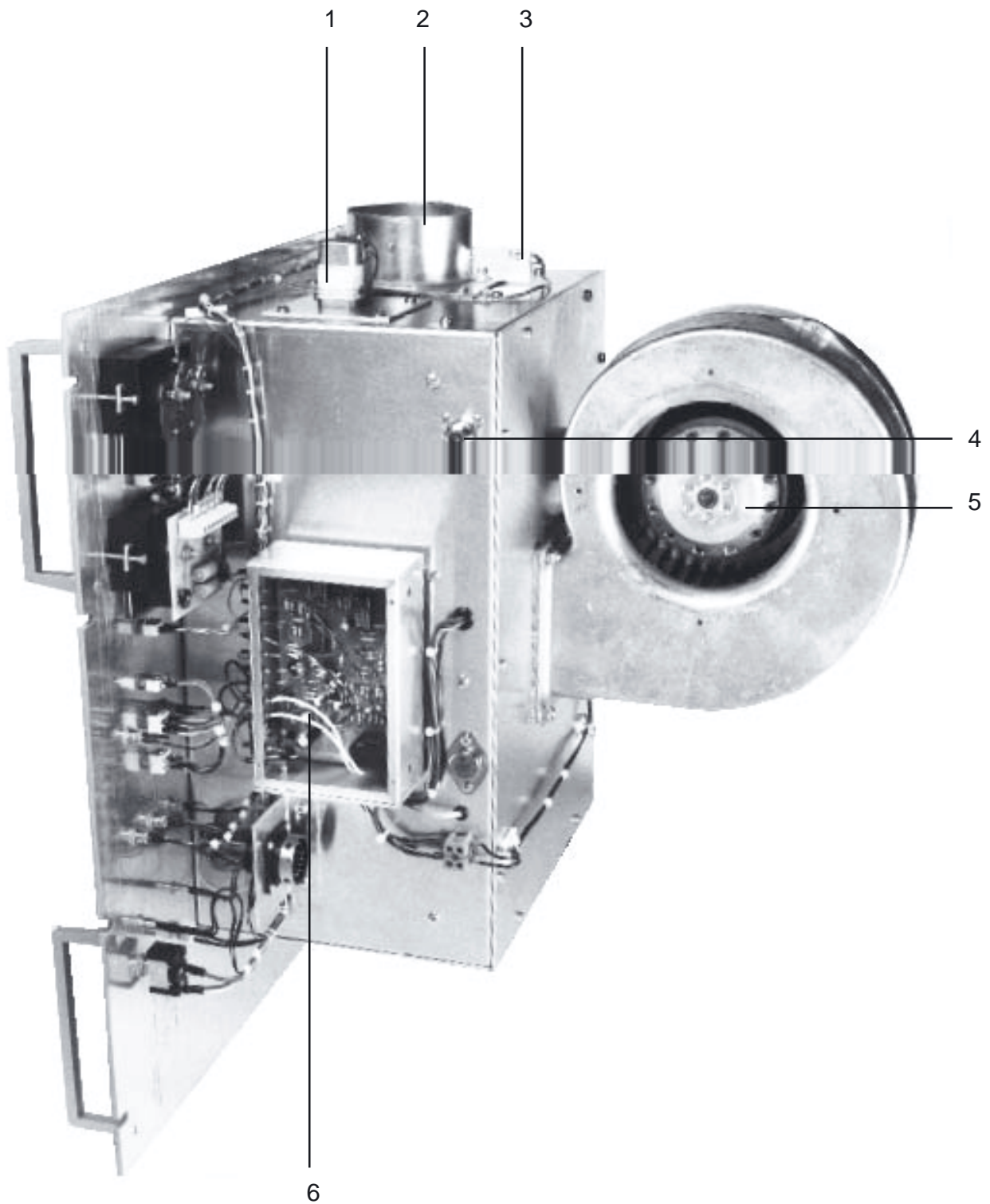


PHOTO 2

R.F. BLOCK'S VIEW 2 DESCRIPTION (PHOTO 3)

- 1 Filament transformer
- 2 End of tuning range switch (87.5 Mhz)
- 3 Input Matching Board
- 4 Load tuning control motor
- 5 End of tuning control motor (108 Mhz)
- 7 Multipolar circular connector
- 8 Grid/Plate meter board

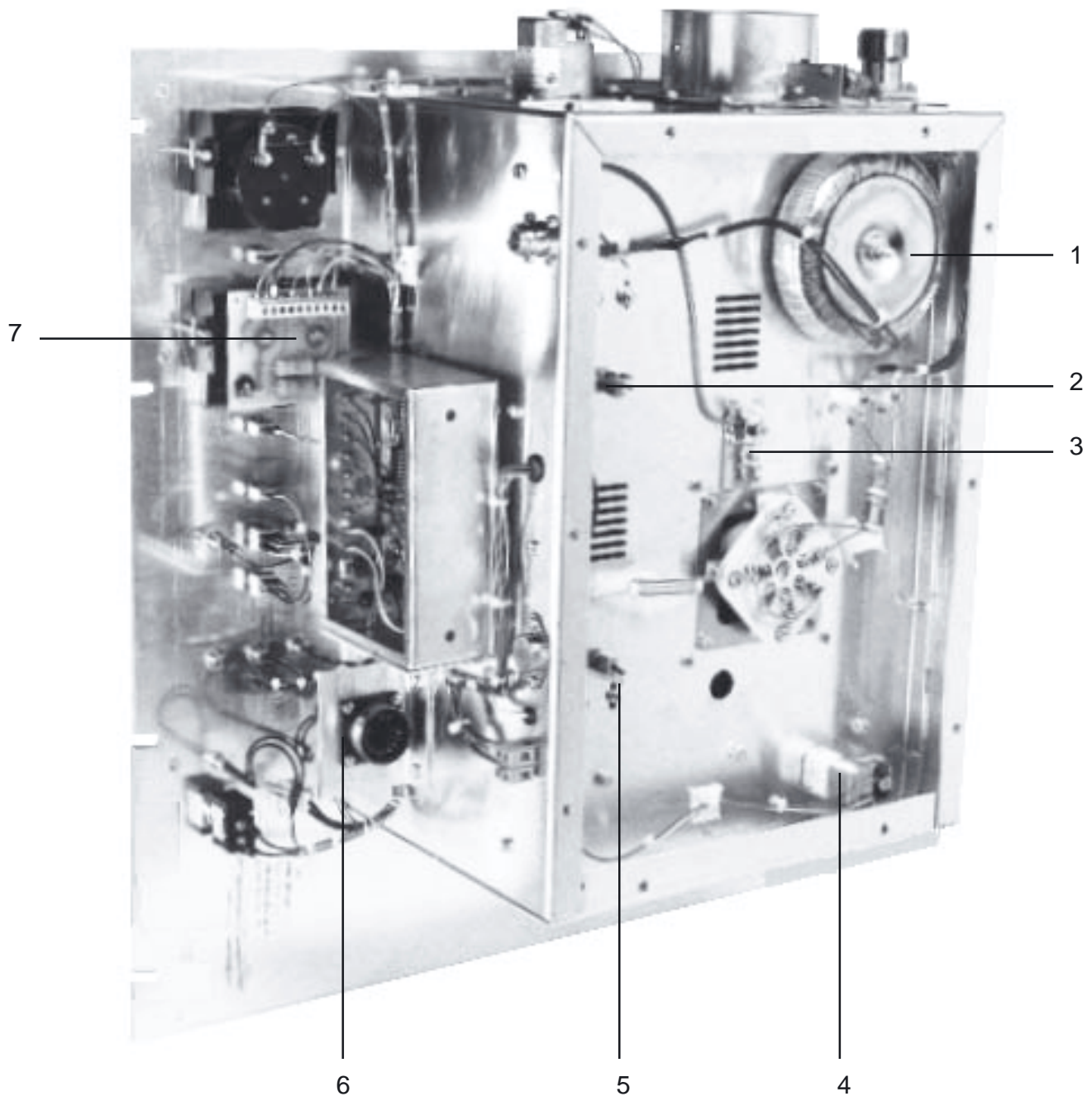


PHOTO 3

TABLE D

TYPICAL VALUES OF THE OPERATING PARAMETERS

Power VoltageNominal Tension $\pm 5\%$ MAXCOS-FI better than 0,9

Output Power

1 KW approx

Input Power

18-20 W

Anode Current

0,45 A

Grid Current

< or = 20 mA

Input SWR

2 W MAX

6. Installation Procedure

6.1 Introduction

This chapter contains information necessary for the installation and initial testing of the VJ1000HP amplifier.

Is necessary, to not damage the amplifier, to execute the procedure below in the right sequence.

6.2 Unpacking

Remove the unit from its packing and, before any other operation, ensure that the unit has not suffered any damage in transit and that all its front panel controls are useable.

6.3 Fitting the Tube

To fit the tube follow the following instructions:

- 1) Unscrew the screws holding the high voltage front panel (17 Fig.1) and open it.
- 2) Check with care that the tube's pins are correctly aligned with its socket.
- 3) Insert the tube into its socket, pressing lightly and first rechecking the correct alignment of the pins.
- 4) Check that the tube is fully home in its socket, verifying the correct fit of the grid ring.
- 5) Shut the high voltage panel and re-fit all the screws.

6.4 Connection and Setup Procedures

To connect the unit, follow the following instructions:

- 1) Remove the rear panel.
- 2) Connect a cable of suitable dimensions (the unit can draw up to 15A) to the power input connector block.
- 3) Connect the exciter supply cable to the corresponding connector block, taking care to connect the earth (ground) to its correct connector.
- 4) Connect a 50 Ohm coaxial cable (type RG 213) fitted with an "N" type male connector to the input connector.
- 5) Connect an antenna or a dummy load with an impedance of 50 Ohm to the output connector type 7/8" (7/16" or LC on request).

Ensure that the coaxial cable has an impedance of 50 Ohm and that it can handle a continuous power of at least 1000 Watts.

- 6) After having connected the 220 V driver supply and an RF output connector to the driver, switch the VJ1000HP's POWER switch to OFF and the ST.BY. switch to ON.
- 7) Adjust the exciter power output control to minimum power.
- 8) Connect the line supply (220V \pm 5%) to the unit.
- 9) Switch the POWER switch to ON, the corresponding indicator will show the presence of the line supply in the unit and, at the same time the cooling fan will start.

Normally the PRESS. indicator will stay on for a few seconds before the fan has created sufficient air flow.

After 2-3 minutes of warming up, the HT indicator will light up; simultaneously the characteristic noise of the power solenoid will be heard indicating that the anode supply is active.

The driver will also be active.

The unit without excitation will absorb about 80 mA of anode current.

- 10) Switch the OUTPUT POWER switch to DIR and the CURRENTS switch to PLATE.
- 11) Adjust the exciter power control to obtain a anode current of 150/200 mA.
- 12) Using the TUNING switch, activate the tuning motors so that both green leds next to the PLATE control light up.

Holding the TUNING switch down, use the PLATE "+" or "-" control (the unit is factory-set to a frequency of 98 MHz) to tune the anode circuit.

"+" indicates an increase in frequency, and "-" a reduction in frequency.

If one of the leds switches off, this indicates that the end of the frequency range has been reached and that no more adjustment is available in that direction.

The OUTPUT POWER meter can be used to tune the anode circuit; maximum meter reading (maximum output power) corresponding to correct tuning.

- 13) The LOAD tuning procedure follows in a similar fashion: holding down the TUNING switch, adjust the LOAD control for maximum output power.

REPEAT STEPS 12 AND 13 SEVERAL TIMES TO OBTAIN THE OPTIMUM SETTINGS

- 14) Increase exciter power until an output power of 800/850 W is obtained and repeat steps 12 and 13.

Note: The driver power don't never must excess 25W, then the maximum Plate current is 500mA and the maximum Grig current is 35mA

- 15) With output power at 1000 W, make small adjustments, as above, to minimize grid and anode currents; if necessary, reduce exciter power to maintain 1000 W of output power.

6.5 Fault Finding during the Setup Procedure

The following fault conditions may occur during the setup procedure:

1) THE RED LIGHT "PRESS." STAYS ON

Check that the rear air filter is not blocked and that there is at least 40/50 cm clearance between the rear of the unit and any obstructions such as a wall.

Check that the air exit flue is free from obstruction.

2) THE S.W.R. INDICATOR LIGHTS UP DURING THE TUNING PROCEDURE

Check for standing waves on the antenna with a wattmeter. The reading should be less than 100 W.

3) THE GRID INDICATOR LIGHTS UP DURING THE CALIBRATION PROCEDURE

Reduce output power and carefully re-tune the output (LOAD and PLATE).

WARNING: The inside of the unit operates at high voltages which are dangerous and potentially lethal. For this reason the unit should only be operated with all its panels securely in place. The unit must be connected to a good earth. The unit should be operated in a well ventilated environment the hot air expelled by the unit will rapidly raise the temperature of a poorly ventilated environment with potentially damaging consequences.

Should operation of the unit be inhibited by the protection system, do not attempt to re-activate the unit without carefully checking operating and environmental parameters.

4) THE EQUIPMENT DOESN'T SUPPLY THE NOMINAL POWER INDICATED ON THE TEST REPORT ALTHOUGH THE ADJUSTMENT OPERATION IS BEEN MADE CORRECTLY.

Verify that the line voltage, under load, has the nominal value $\pm 5\%$ max.

Verify the COS-FI value on the line; this value must be better than 0.9.

Otherwise correct the power factor of the line.

TABLE E**RECOMMENDED TEST EQUIPMENT**

INSTRUMENT TYPE	SUGGESTED MODEL	TECH. SPECIFICATIONS
Non Inductive Dummy Load	Bird	50 Ohm P >1KW
Non Inductive Dummy Load	Bird	50 Ohm P >1KW
Calibrated in-line Wattmeter with Sample	Bird MOD. 43	50 Ohm
Power Supply	HP Mod. 6002A	0-50V, 0-10A

7. Maintenance Procedure

7.1 Safety Procedures

WARNING WARNING WARNING WARNING WARNING WARNING WARNING WARNING

When the amplifier is operational with the rear panel removed, lethal voltages are easily accessible.

Use properly insulated tools for any calibration work and do not make contact with any internal components.

Ensure that all high voltage components have been grounded (use an earthing stick).

Ensure that power has been disconnected from the unit before any maintenance work is started.

FIRST LEVEL OF MAINTENANCE

7.2 Routine Maintenance

The only routine maintenance required by the amplifier is periodic changing of the fan, air filter and removal of accumulated dust from inside the tube cavity and from the air filter.

The periods between routine maintenance will depend upon operating conditions, ambient temperature, ambient dust levels and humidity. It is advisable to carry out preventative checks at 3 month intervals and to change fans at least every 18 months, or before if they become noisy or show signs of wear.

Periodic replacement of the tube will also be necessary.

The operating life of the tube is very dependant upon operating conditions, for example: line voltage fluctuations over $\pm 5\%$, temperatures over $+30^{\circ}\text{C}$, high humidity, the presence of dust and incorrect calibration of the amplifier will all result in a greatly reduced tube life.

SECOND LEVEL OF MAINTENANCE

7.3 Replacement of Components

N.B. TO RE-ASSEMBLE THE UNIT, SIMPLY REVERSE THE SEQUENCE OF OPERATIONS.

N.B. THE FOLLOWING PROCEDURE SHOULD ONLY BE CARRIED OUT BY QUALIFIED PERSONNEL USING THE CORRECT TOOLS AND EQUIPMENT. UNQUALIFIED OR INEXPERIENCED PERSONNEL NOT USING THE CORRECT TOOLS AND EQUIPMENT CAN EASILY CAUSE DAMAGE TO THE UNIT WHICH WILL IMMEDIATELY INVALIDATE THE GUARANTEE.

7.4 Replacement of the Tube

- 1) Ensure that the unit is isolated from its supply and, to avoid severe burns, that the tube that has to be replaced is no longer hot.

Ensure also that all terminals are at 0V, and if not use a shorting stick to remove any residual charge.

- 2) Undo the fixing screws holding the tube access panel (17 Fig.1) to the front panel and remove the access panel.
- 3) Remove the tube from its supporting socket, pulling in a direction perpendicular to its socket.
- 4) Should the tube prove excessively difficult to extract, unscrew the four screws holding the base of the anode contacts to the 4 teflon pillars.

Once the tube has been extracted from its socket, attempt to remove the anode contacts taking care not to damage them.

Re-mount the base on its pillars, without the tube.

- 5) To fit the new tube, follow the procedure from step 2 to step 5 in paragraph 3.3 FITTING THE TUBE.

7.5 Changing the Air Filter

- 1) Disconnect power from the unit.
- 2) Open the rear grill of the air filter by unscrewing the fixing screws.
- 3) Change the filter cleaning the inside with care.
- 4) Close the rear grill and tighten the fixing screws.
- 5) Reconnect power to the unit.

8. Calibration Procedure

N.B. THE FOLLOWING PROCEDURE SHOULD ONLY BE CARRIED OUT BY QUALIFIED PERSONNEL USING THE CORRECT TOOLS AND EQUIPMENT. UNQUALIFIED OR INEXPERIENCED PERSONNEL NOT USING THE CORRECT TOOLS AND EQUIPMENT CAN EASILY CAUSE DAMAGE TO THE UNIT WHICH WILL IMMEDIATELY INVALIDATE THE GUARANTEE.

8.1 Frequency Changes

To change the operating frequency of a tube amplifier the following procedure is required:

- 1) Select the desired frequency on the exciter.
- 2) Reduce exciter power to minimum power.
- 3) Connect the line supply (220V \pm 5%) to the unit.
- 4) Switch the POWER switch to ON, the corresponding indicator will show the presence of the line supply in the unit and, at the same time the cooling fan will start.

Normally the PRESS. indicator will stay on for a few seconds before the fan has created sufficient air flow.

After 2/3 minutes of warming up, the HT indicator will light up; simultaneously the characteristic noise of the power solenoid will be heard indicating that the anode supply is active.

The driver will also be active. The unit without excitation will absorb about 30 mA of anode current.

- 5) Switch the OUTPUT POWER switch to DIR and the CURRENTS switch to PLATE.
- 6) Adjust the exciter power control to obtain an anode current of 200mA.
- 7) Using the TUNING switch, activate the tuning motors so that both green leds next to the PLATE control light up.

Holding the TUNING switch down, use the PLATE "+" or "-" control (the unit is factory set to a frequency of 98 MHz) to tune the plate circuit.

"+" indicates an increase in frequency and "-", a reduction in frequency.

If one of the leds switches off, this indicates that the end of the frequency range has been reached and that no more adjustment is available in that direction.

The OUTPUT POWER meter can be used to tune the plate circuit; maximum meter reading (maximum output power) corresponding to correct tuning.

- 8) The LOAD tuning procedure follows in a similar fashion: holding down the TUNING switch, adjust the LOAD control for maximum output power.

REPEAT STEPS 7 AND 8 SEVERAL TIMES TO OBTAIN THE OPTIMUM SETTINGS

- 9) Increase exciter power until an output power of 800/850 W is obtained and repeat steps 7 and 8.
- 10) With output power at 1000 W, make small adjustments, as above, to minimize grid and anode currents; if necessary, reduce exciter power to maintain 1000 W of output power.

8.2 Calibration of the Protection Card

Before calibrating the protection board, or IG and IA currents, remove the front panel which also supports the RF chamber.

Disconnect the antenna output cable, remove the coaxial cable from the input connector, undo the 8 screws holding the panel and remove the panel; take care not to disturb the high voltage cables and the multipolar service cable.

Lay the chamber carefully on a raised surface, opposite the unit to facilitate the following procedure.

The protection board has three trimmers for adjusting the following alarm thresholds: insufficient fan pressure, excess V.S.W.R. and excess grid current.

These alarm conditions are indicated by three leds (Alarms Fig.1).

Remove the metal cover of the protection box by undoing the 4 screws.

The alarm thresholds may be calibrated through the following procedure:

- 1) CALIBRATION OF FAN PRESSURE ALARM THRESHOLD (PRESS.).
 - a) Switch the ST.BY. switch (15 Fig.1) to ST.BY.
 - b) Enable power to the unit by switching the POWER switch (16 Fig.1) to ON.
 - c) Ensure that the PRESS. indicator (11 Fig.1), initially on, turns off when the air-flow switch (3 Photo3), positioned inside the flue, switches up (air pressure normal).

Two error conditions can prevent the above sequence from being completed: the indicator remains on, or remains permanently off.

In this case adjust the trimmer, R4, until the sequence is completed correctly: switch down, led on; switch up, led off.

- 2) CALIBRATION OF V.S.W.R.

To adjust the threshold of the V.S.W.R. alarm first perform SETUP1 (Fig.3). The threshold should be set at around 10 % of the maximum output power i.e. of 100W.

- a) Connect a mismatched, dummy load (e.g. 25 Ohms 1.5KW) to the RF output of the amplifier, in series with a bypass wattmeter.b). With the unit switched on (N.B. the rear cover must be in place) and having calibrated the unit to its exciter frequency, gradually increase the output power from 0W until a reflected power of 100W is registered on the external wattmeter.
- c) Adjust the trimmer R7 until the alarm threshold is reached and the V.S.W.R. led lights up (10 Fig.1).

N.B. Several attempts may be necessary. At least 60 seconds should be allowed inbetween attempts to allow an automatic reset.

- 3) CALIBRATION OF THE GRID CURRENT (IG) ALARM THRESHOLD
 - a) Connect the unit to the line supply and connect a dummy load (50Ohms 1.5KW).
 - b) Switch the ST.BY. switch (15 Fig.1) to ST.BY.
 - c) Wait for the fan to build up pressure.
 - d) Perform the SETUP 3 procedure and steps required to calibrate the grid current IG (paragraph 5.5).
 - e) Adjust the reading (regulating the supply) to 40 mA.
 - f) Adjust trimmer R21 until the IG protection is activated i.e. when the IG indicator (12 Fig.1) comes on.
 - g) Reduce the indicated current to 30 mA.
 - h) Wait for the automatic protection cycle to complete and repeat step e) to verify the correct alarm threshold (40 mA).

8.3 Calibration of the PWR Meter (REF)

Perform the calibration procedure for the V.S.W.R. protection upto step b) (paragraph 5.2 (2)).

At this point verify that the VJ1000HP meter reading is correct; adjustment may be made with trimer R6 situated in the directional coupler on the output of the low-pass filter, near the antenna connector.

To gain access to it, remove the small protection cover.

8.4 Calibration of the PWR Meter (FWD)

Perform SETUP 2 (Fig.4).

- 1) Connect a 50 Ohm 1.5KW dummy load in series with a bypass wattmeter (Byrd model 43), switch on the amplifier and verify the correct reading of the VJ1000HP's meter.
- 2) Adjust trimmer R9, situated inside the directional coupler on the output of the low-pass filter, near the antenna connector.
- 3) To gain access, remove the small protection cover.

N.B. The trimmer R2 connected in series with the meter allows small adjustments after the calibration of PWR, REF and FWD, and is normally in a central position.

8.5 Calibration of the Grid Current Meter (IG)

Perform SETUP 3 (Fig.5).

- 1) Switch the IG-IA switch to the IG position (4 Fig.1).
- 2) The unit should be switched off.
- 3) Adjust the output voltage of the external power supply to 0V.
- 4) Connect the external power supply to the 2.2 Ohm, 5W resistor R4 situated on the rear of the meter (current).

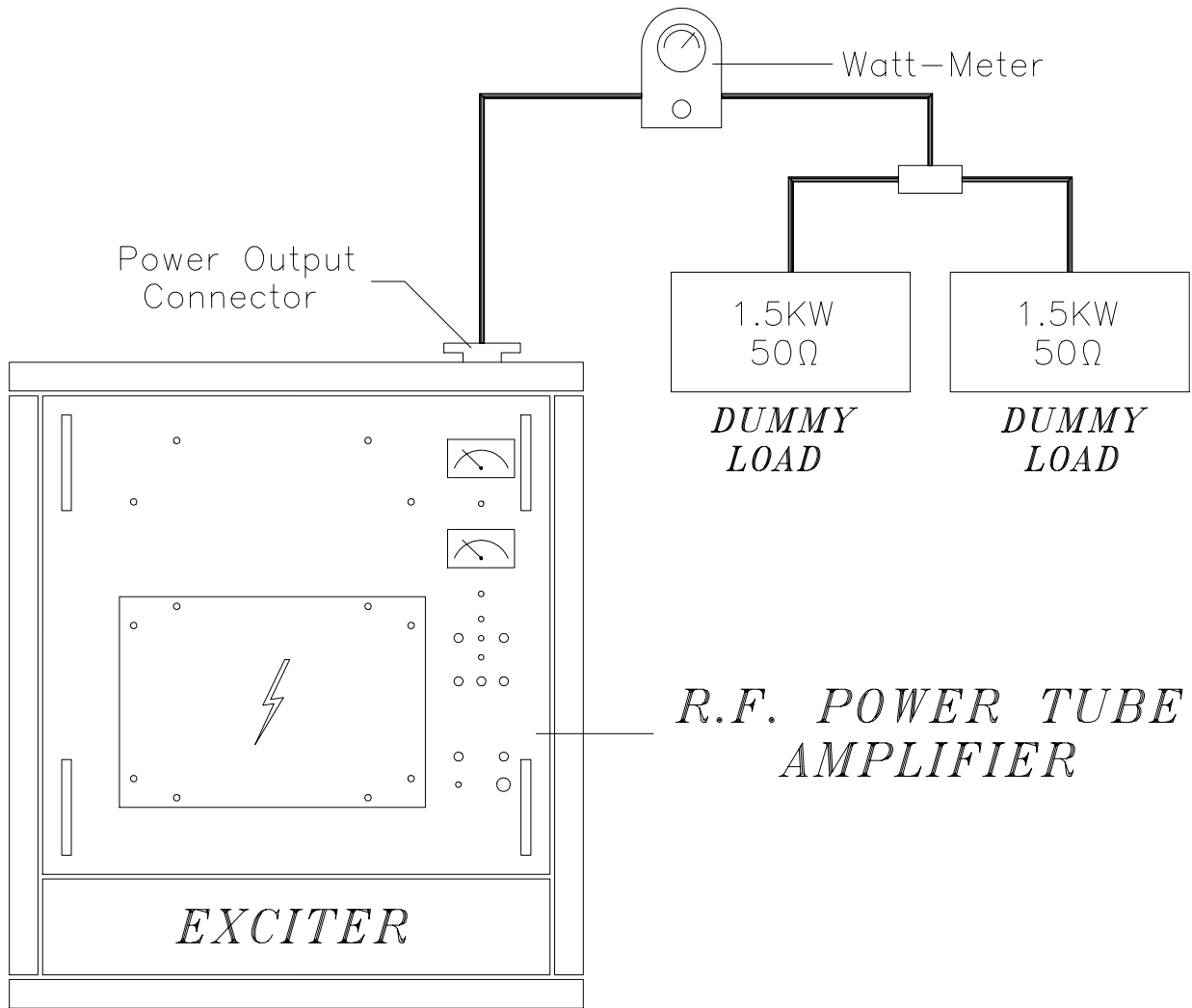
The polarity should be such as to produce a clockwise deflection.

- 5) Increase the power supply voltage and check for a proportional increase in the grid current (as measured by the VJ1000HP meter) and in the current supplied by the power supply.
- 6) Adjust trimmer R2 for a correct reading.

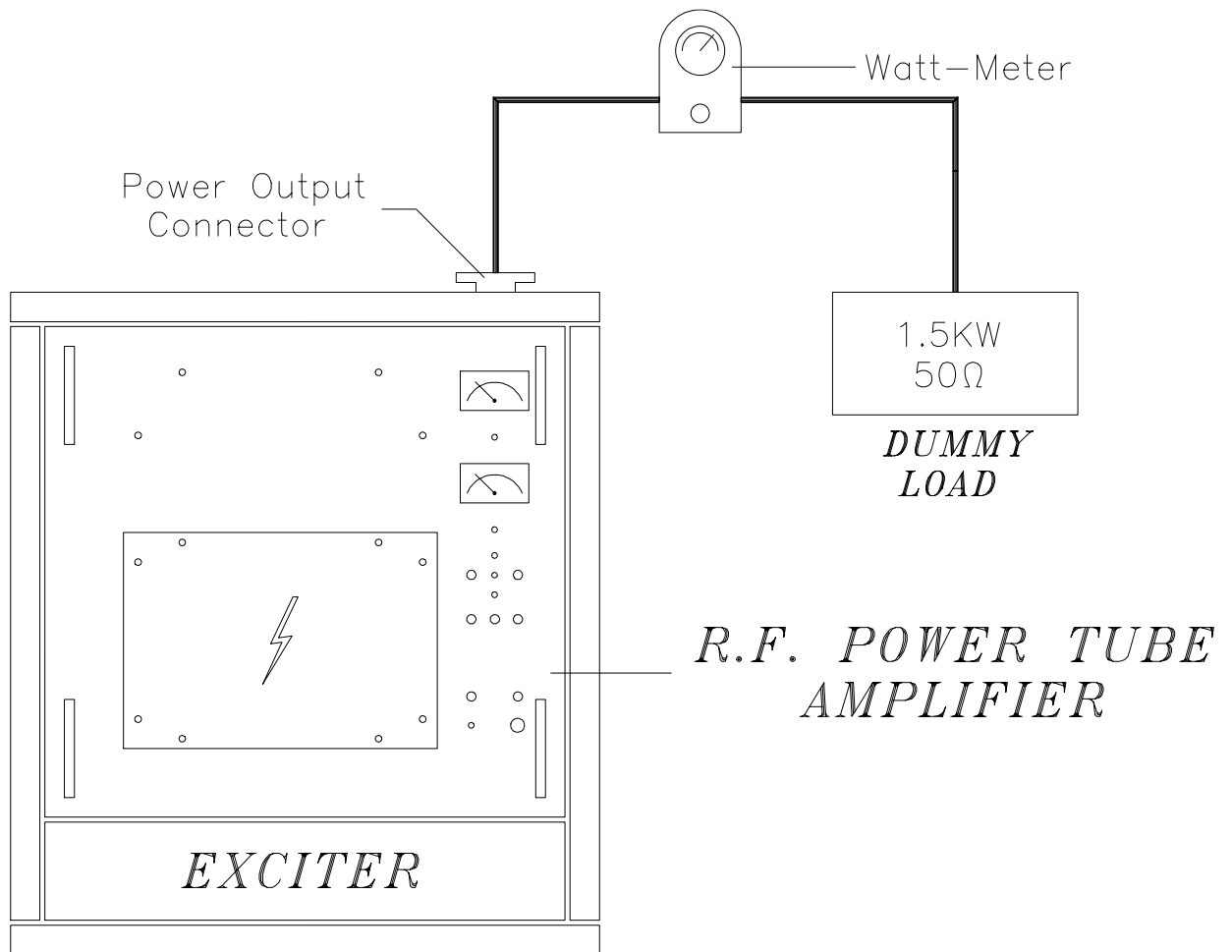
8.6 Calibration of Anode Measurement (IA)

Perform SETUP 3 (Fig.5).

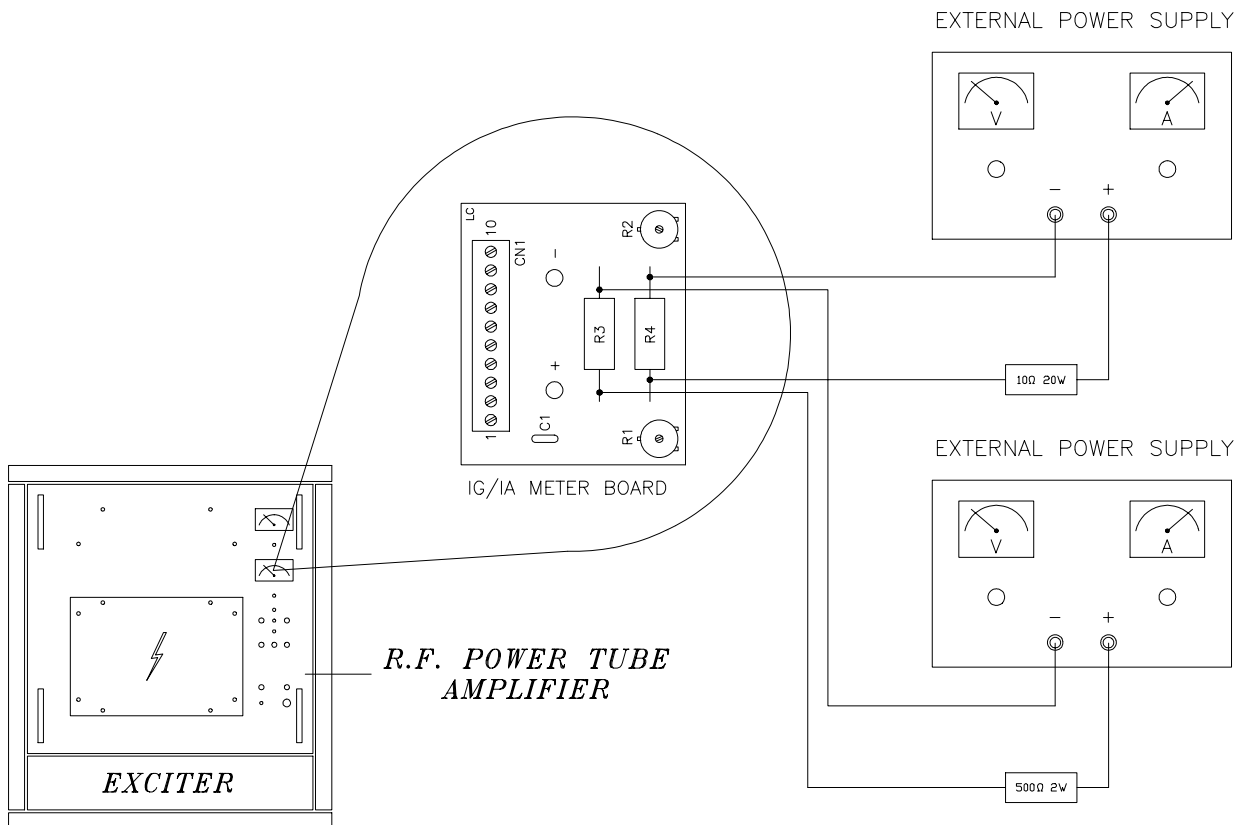
Perform the procedure detailed for the calibration of the grid current measurement, but instead connect the power supply to the R3 0.22 Ohm resistor found on the same board. Use R1 to calibrate the IA meter.



SETUP 1 / FIG. 3



SETUP 2 / FIG. 4

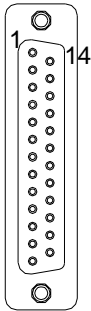


SETUP 3 / FIG. 5

9. Connectors Description

9.1 Telemetry Connector

Type: DB25 Female



1	Anodic Voltage Output (ONLY VJ2000)	3V X 4000V
2	Anodic Current Measurement Output	5V X 1A
3	GND	0V
4	Reflected Power Measurement Output	1.4V X 100W
5	Not Used	
6	Not Used	
7	Not Used	
8	Input Command ON (High Voltage)	
9	Not Used	
10	Not Used	
11	Not Used	
12	Not Used	
13	Not Used	
14	Not Used	
15	Not Used	
16	Forward Power Measurement Output	1.6V X 1000W
17	Antenna Alarm SWR (This Signal come directly from the Alarms Card)	12V when fault
18	Grid Current Measurement Output	5V X 100mA
19	Not Used	
20	Input ON	
21	Not Used	
22	Not Used	
23	Not Used	
24	Not Used	
25	Not Used	

10. Telemetry Card Option

10.1 Calibration of the Voltages on the Telemetry connector

The VJ's internal Telemetry connector gives to the external the voltages referred to the various values under control. The voltage related to the Forward Power output is 1,6V for 1KW. To calibrate this voltage follow the procedure below:

- 1- Adjust the power of the machine to the nominal value of 1KW.
- 2- Adjust R13 on the Telemetry Card to obtain a voltage, between pin 16 and pin 1 of Telemetry connector, of 1,6V.

The pin 4 gives the voltage referred to measurement of the Reflected Power. This voltage is 1,4V for 100W (10% of 1KW). To calibrate this voltage follow the procedure below:

- 1- Adjust the Reflected Power to 100W using a wattmeter Bird in output.
- 2- Adjust R14 of Telemetry Card to obtain a voltage, between pin 14 and pin 1 of connector, of 1,4V.
- 3- Adjust R36 to set the Power Good threshold.

10.2 Wiring Connections details

- 1- The exciter is not supplied from the Service Connector but separately. This is because if there was no high voltage, the Service Connector would be not supplies instead, too. The exciter shall be ever ON.
- 2- A system that closes to earth a BNC contact when the machine is in Standby mode is used. This contact is connected with a BNC-BNC cable to the Interlock/ RF Mute connector of the exciter. When the VJ goes in Standby status, the exciter enters in RF Mute mode. The contact that permits this functionality is located on the Service teleswitch.
- 3- A Reset (or Restart) button is connected between pin 9 and earth of Telemetry Card JP2 connector and it's located on the front panel. It's used to give the same kind of signal as the an exciter that an PTXLCD gives when it is switches ON. This operation resets the alarms and the remote control relay, in case the amplifier is in OFF status and there is not an exciter able to change it to the ON status.
- 4- The Alarms Card is supplied by the alternate current that first passes throught JP3 (pin 1 and 2) of telemetry. When the Telemetry Card receives the REMOTE OFF command, Alarms Card turns OFF itself. This permits to remotly reset the alarms throught an ON-OFF-ON sequency. Please remember that after 6 attempts failed the machine will block itself. This remote control system gives a remote reactivation mechanism.
- 5- A green LED is mounted between the point S of the Alarm Card and ground (throught a 2K2 resistor); this is to indicate whether the Alarms Cards is supplied

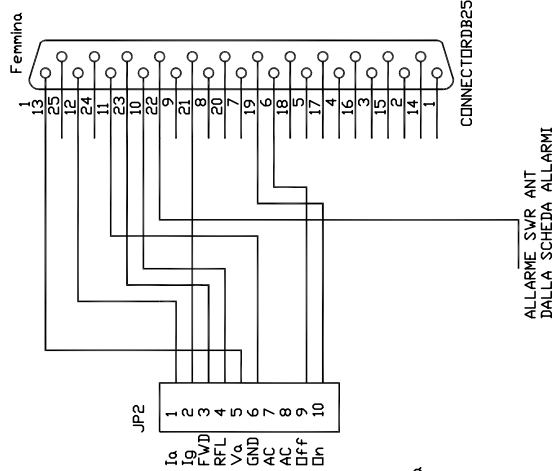
or not.

- 6- The DB25/telemetry connector cable is connected as shown in the diagrams in appendix.
- 7- The system is the same for VJ1000 and VJ2000.

10.3 General Verifications

- When Standby mode and operating the related switch, the exciter shall go in RF Mute mode.
- VJ1000/2000 shall switch to Standby mode if the exciter put in the OFF status.
- If the VJ has completed a reset cycle for 6 times and it's thus blocked, a series of ON-OFF-ON of the exciter shall reset the alarms.
- Only the SWR ANT Alarm is telecontrolled.

This page intentionally left blank



Conn. JP2 Telemetry card	Connettore DB25 femmina
1 - uscita Ia	2 - uscita Ia
2 - uscita Ig	18 - uscita Ig
3 - uscita potenza diretta	16 - uscita potenza diretta
4 - uscita potenza riflessa	4 - uscita potenza riflessa
5 - uscita Va	1 - uscita Va
6 - GND	3 - GND
7 - ingresso AC	NC
8 - ingresso AC	NC
9 - ingresso REMOTE DN	8 - ingresso REMOTE DN
10 - ingresso REMOTE DFF	20 - ingresso REMOTE DFF
	17 - allarme SVR

REMOTE DN (DFF) sono i contatti che il PTX chiude verso massa.
 REMOTE DN significa che chiudendo a massa questo contatto
 la macchina va in DN, cioè, se e' l'interruttore della
 alta tensione e' attivato, allora si puo' andare in potenza

Nota : Il pin 17 del DB25 femmina va collegato direttamente al filo
 ALLARME SVR proveniente dalla scheda allarmi.

Co: RVR Elettronica

Title: Cavo flat per VJ1000/2000

Board: 1 Revision: A

Author: Ing. Pierluigi Guerzoni

Size: A

Date: 9/2/2001

Sheet 1 of 1

Pagina lasciata intenzionalmente in bianco

This page was intentionally left blank

Cavo Telemetria per VJ1000/2000 --- PTXLCD

Nel menu' Exsts del PTX LCD si ha :
 V1 : VA (3 V per 4000 V SOLO VJ2000)
 V2 : IA (5 V per 1 A)
 V3 : IG (5 V per 100mA)
 V4 : Allarme SWR ANT (4,8V when Fault)
 V5 : NON USAIO
 V6 : NON USAIO

Nel menu' ExpVR del PTX LCD si ha
 Misura della potenza diretta del finale espressa in %
 Misura della potenza riflessa del finale espressa in %
 (queste misure vanno agglustate con i trimmer posti sul retro)

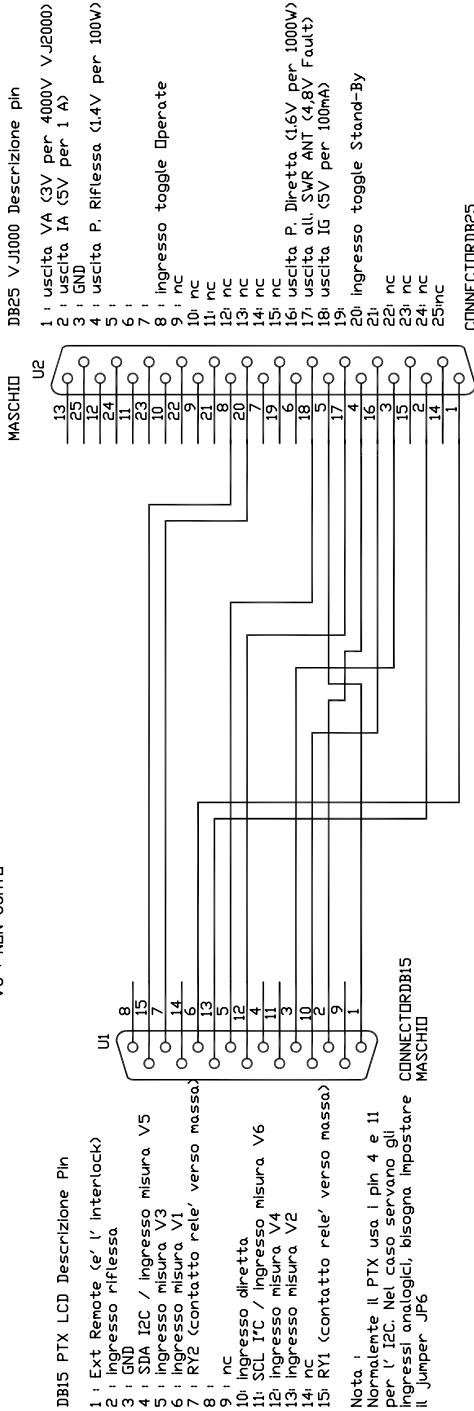


Tabella Corrispondenze

DB15 Maschio (PTX)	DB25 Maschio (VJ-1000)
1 ExtRemote	5 NON USATO NEL VJ1000
2 Ingresso riflessa	4 uscita potenza riflessa (1.4V per 100W)
3 calza	3 calza
4 In An3 (V3)	18 uscita IG (5V per 100mA)
5 In An1 (V1)	1 uscita VA (3V per 4000V solo VJ2000)
6 RY2	20 Ingresso Stand By : il PTX invia un segnale toggle per mettere in standby il finale
7 Ingresso diretta	16 uscita potenza diretta (1.6 V per 1000W)
8 In An4 (V4)	17 Allarme SWR ANT (4.8V when Fault)
9 In An2 (V2)	2 uscita IA (5V per 1A)
10	8 uscita Operate : il PTX invia un segnale toggle per mettere ON il finale
11	
12	
13	
14	
15	

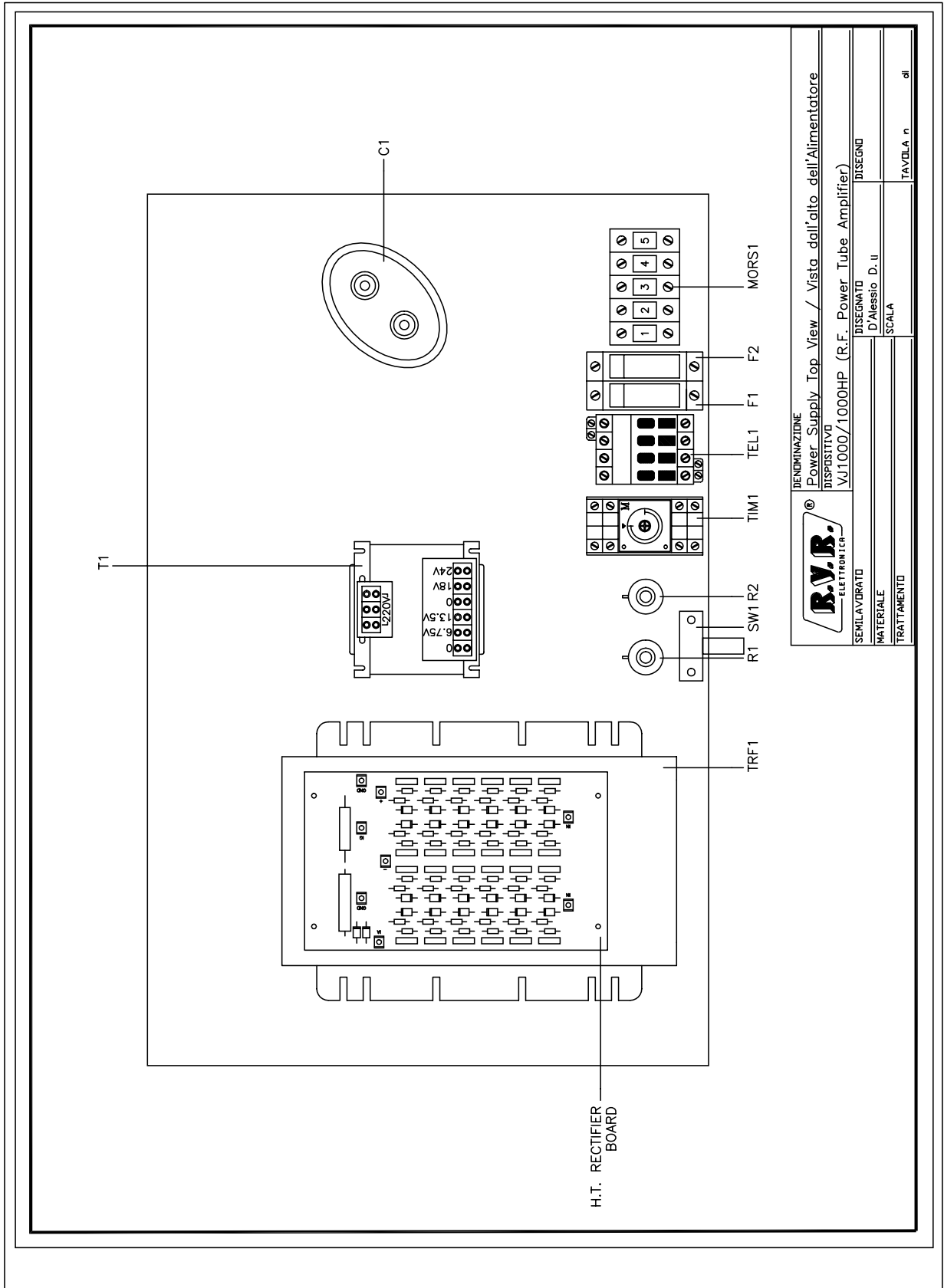
Nota:
 Nel VJ1000 non viene fornita la Va. Il cavo lo prevede per i modelli superiori al VJ1000.

Nota:
 Questo cavo e' identico a quello per il PJ300, ma cambia il significato dei singoli conduttori

Co: RVR Elettronica	
Title: Cavo Telemetria VJ1000/2000	Revision: A
Board: 1	Size: A
Author: Ing. Pierluigi Guerzoni	Sheet 1 of 1
Date: 21/11/2000	

Pagina lasciata intenzionalmente in bianco

This page was intentionally left blank



DENOMINAZIONE	
Power Supply Top View / Vista dall'alto dell'Alimentatore	
DISPOSITIVO	
VJ1000/1000HP (R.F. Power Tube Amplifier)	
DISEGNATO	
D'Alessio D. II	
SCALA	
SEMILAVORATO	
MATERIALE	
TRATTAMENTO	
TAVOLA n.	di

Item	Quantity	Reference	Part	Description	Part Order Code
1	1	R2	15/50W	RESISTOR 50W	
2	1	R1	100/100W	RESISTOR 100W	
3	1	C1	8 μ F 4KV	HIGH VOLTAGE CAPACITOR	
4	2	F1, F2	F16A	FAST FUSIBLE 16A	
5	1	CN1	CON. CIR. 28PF	CON. CIR. 28P BULGIN F. 28PF	
6	1	MORS1	MORS.5*UK16	MORS.5*UK16 PHOENIX	
7	1	J1	BNCFHT	CONN. BNC FEM. PER HT	
8	1	TEL1	RLYFC10N	TEL. MATHSUSHITA FC10N	
9	1	TIM1	TMRPDX3M	TIM. MATS. 24AC 2C 3M	
10	1	SW1	PMS09	PULS. 1V MS09 PIZZATO	
11	1	TRF1	PLATE TRF1 TRF.	220V 2400V 0.9A	
12	1	T1	SERV.TRF1-2TRF.	220/0/18/24	
13	1	SW1	MICRO SWITCH	MICRO SWITCH	

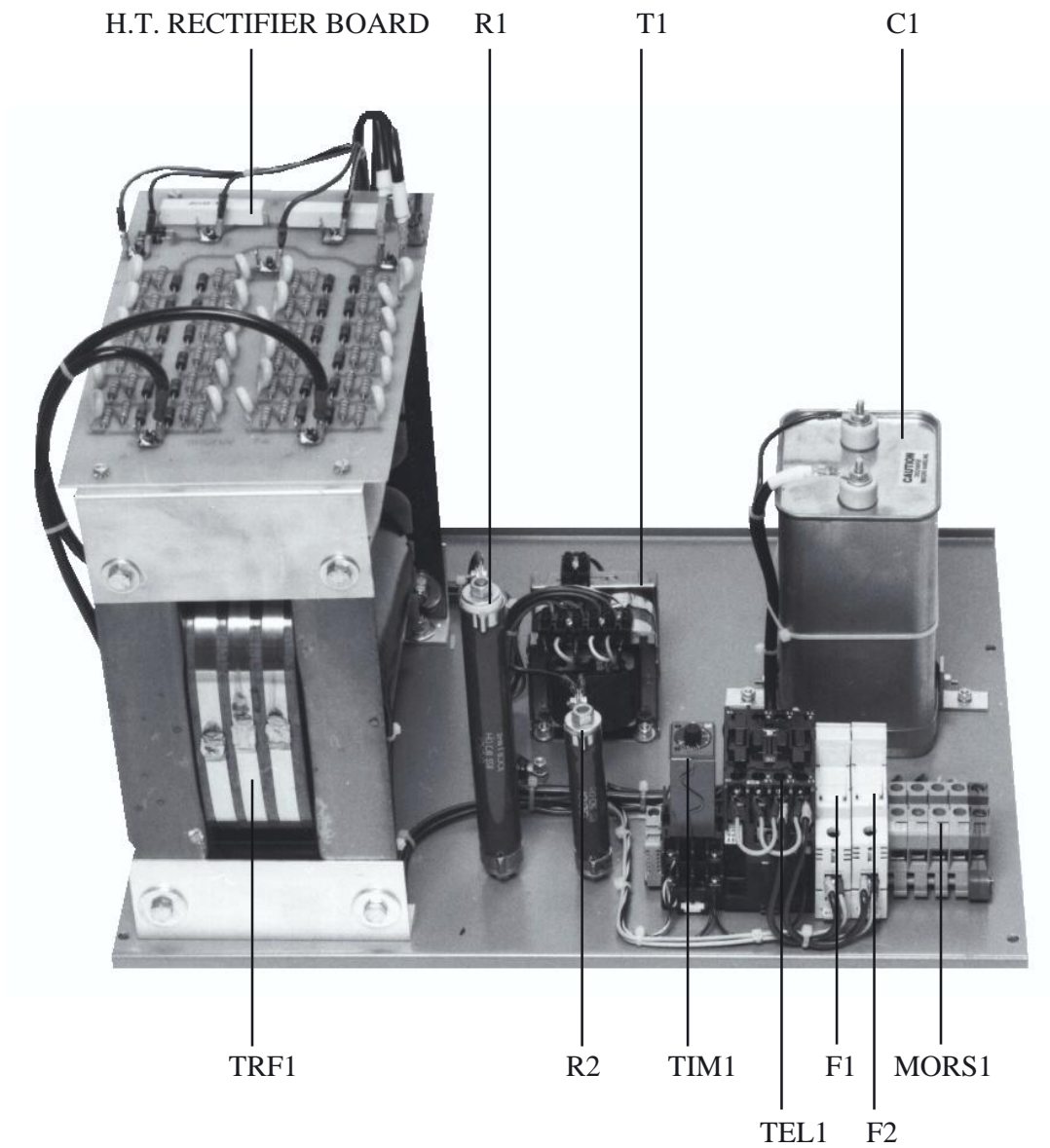
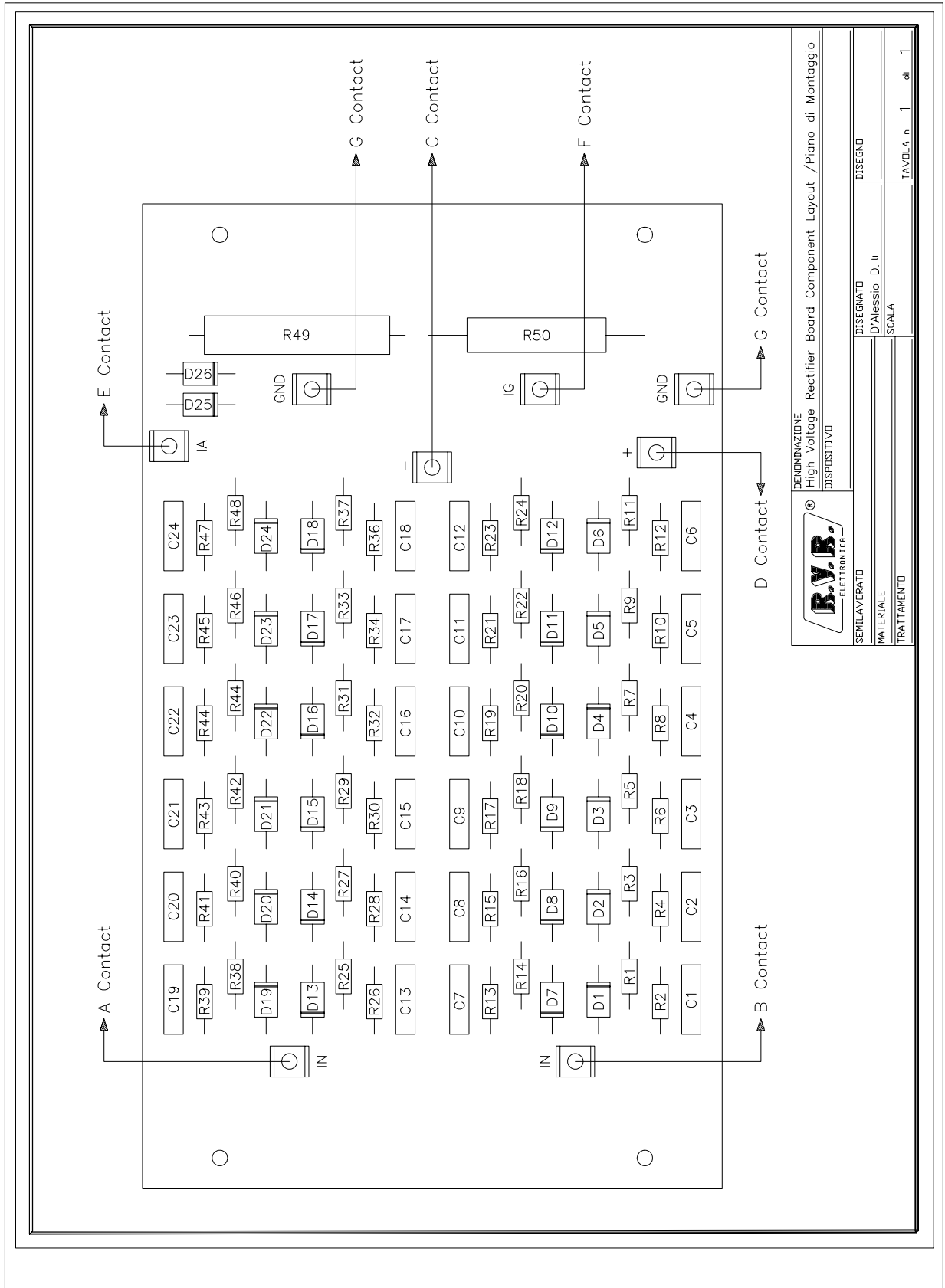
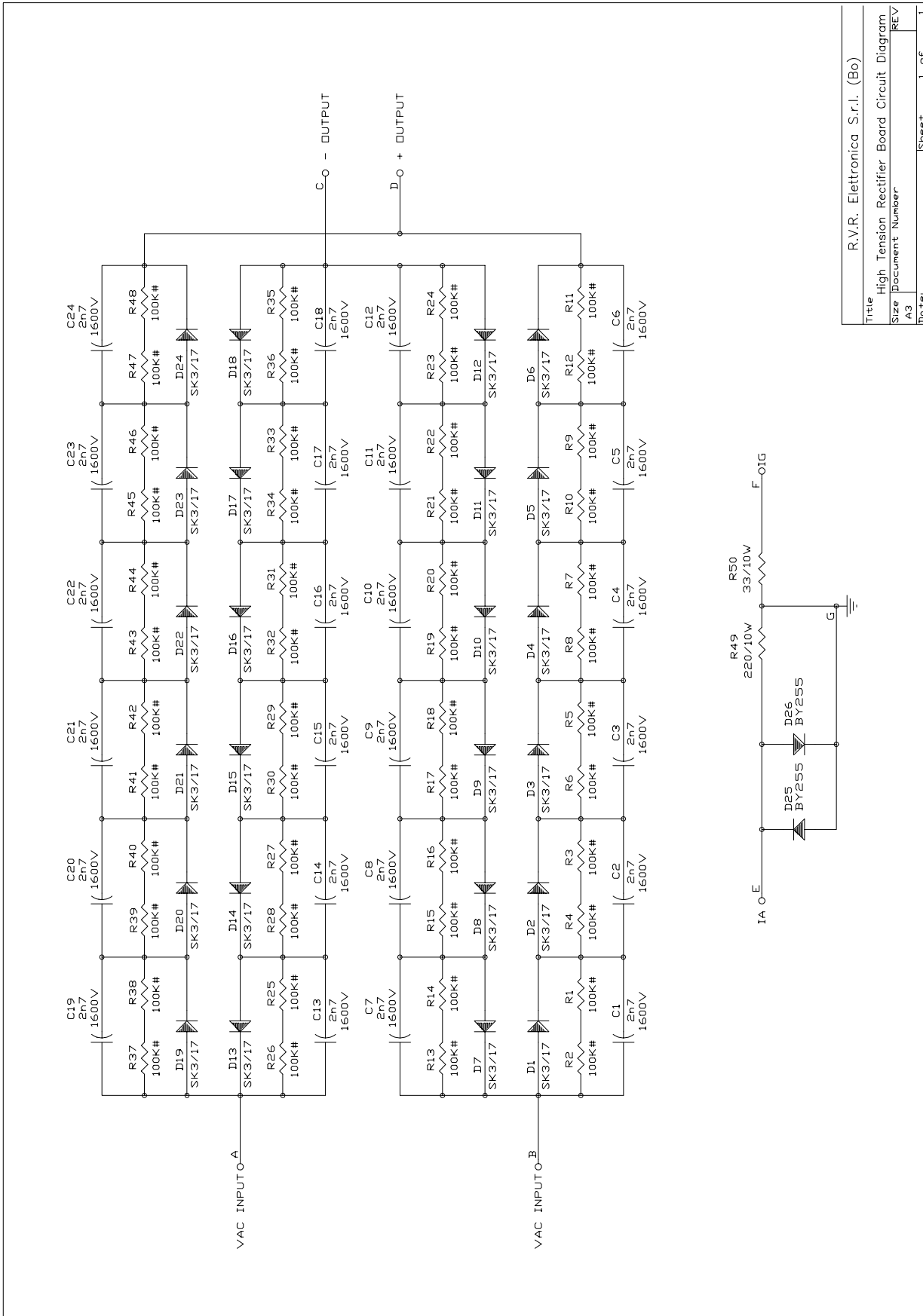


PHOTO 4 / FOTO 4





Title		R.V.R. Elettronica S.r.l. (Bo)
Size		A3
Document Number		REV
Date:	Sheet	1 of 1

H.T. Rectifier Board

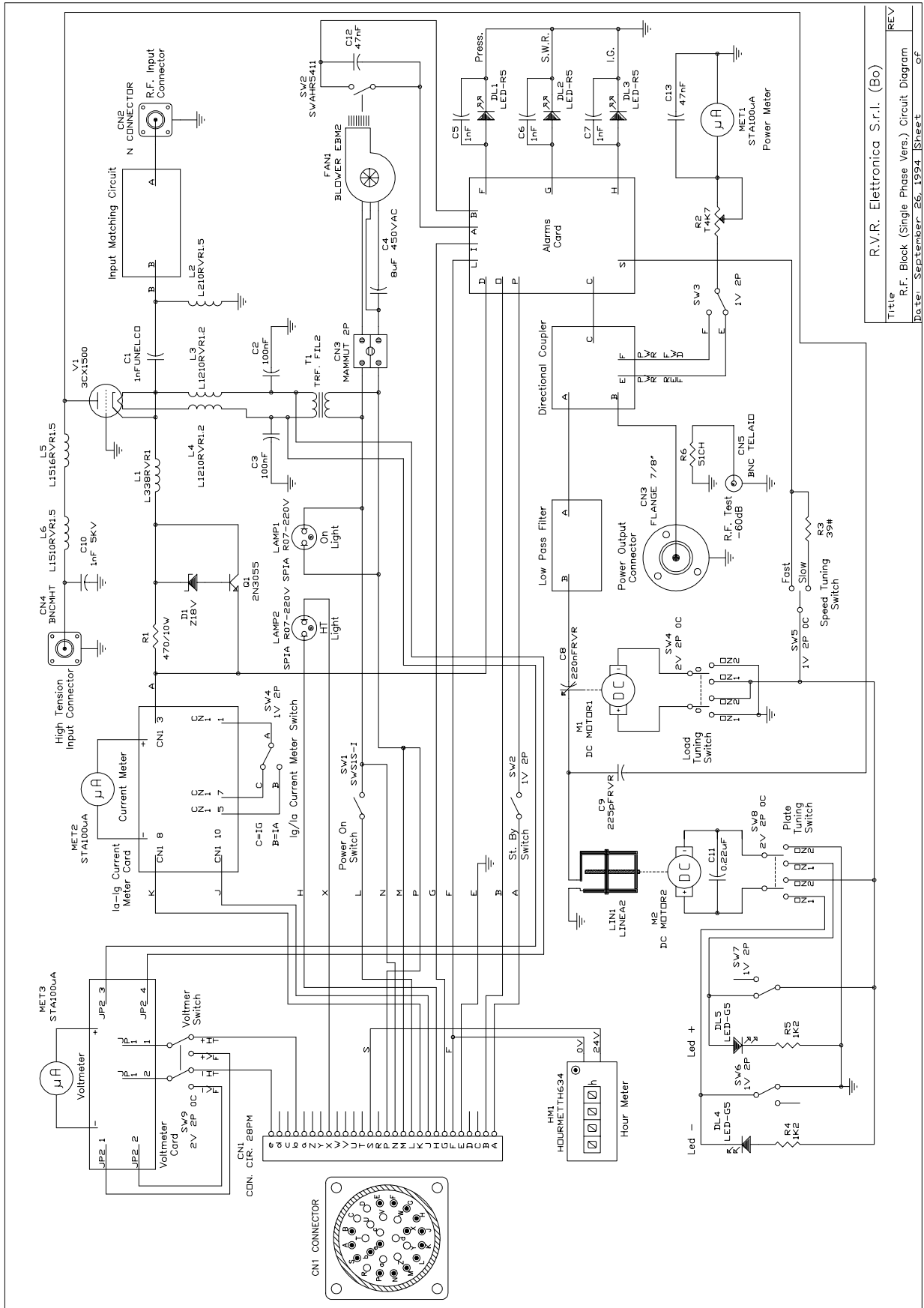
Bill of Materials/Lista Componenti

Pag. 1

Item	Quantity	Reference	Part	Description	Part Order Code
1	1	R50	33/10W	RESISTOR 10W	RAF010KH0033
2	1	R49	220/10W	RESISTOR 10W	RAF010KH0220
3	48	R1,R2,R3, R4,R5,R6, R7,R8,R9, R10,R11,R12, R13,R14,R15, R16,R17,R18, R19,R20,R21, R22,R23,R24, R25,R26,R27, R28,R29,R30, R31,R32,R33, R34,R35,R36, R37,R38,R39, R39,R40,R41, R42,R43,R44, R45,R46,R47, R48	100K#	RESISTOR 2W	RSC002JH0100
4	24	C1,C2,C3, C4,C5,C6, C7,C8,C9, C10,C11,C12, C13,C14,C15, C16,C17,C18, C19,C20,C21, C22,C23,C24	2N7	CERAMIC CAPACITOR	CKM272BK600P
5	24	D1,D2,D3, D4,D5,D6, D7,D8,D9, D10,D11,D12, D13,D14,D15, D16,D17,D18, D19,D20,D21, D22,D23,D24,	SK3/17	SEMICRON DIODE 3A 1700V	DISSK3/17
6	2	D25,D26	BY255	SILICON DIODE 3A 1000V	DISBY255

Pagina lasciata intenzionalmente in bianco

This page was intentionally left blank



REV	
Title	R.F. Block (Single Phase Vers.) Circuit Diagram
Date	September 26, 1954 Sheet

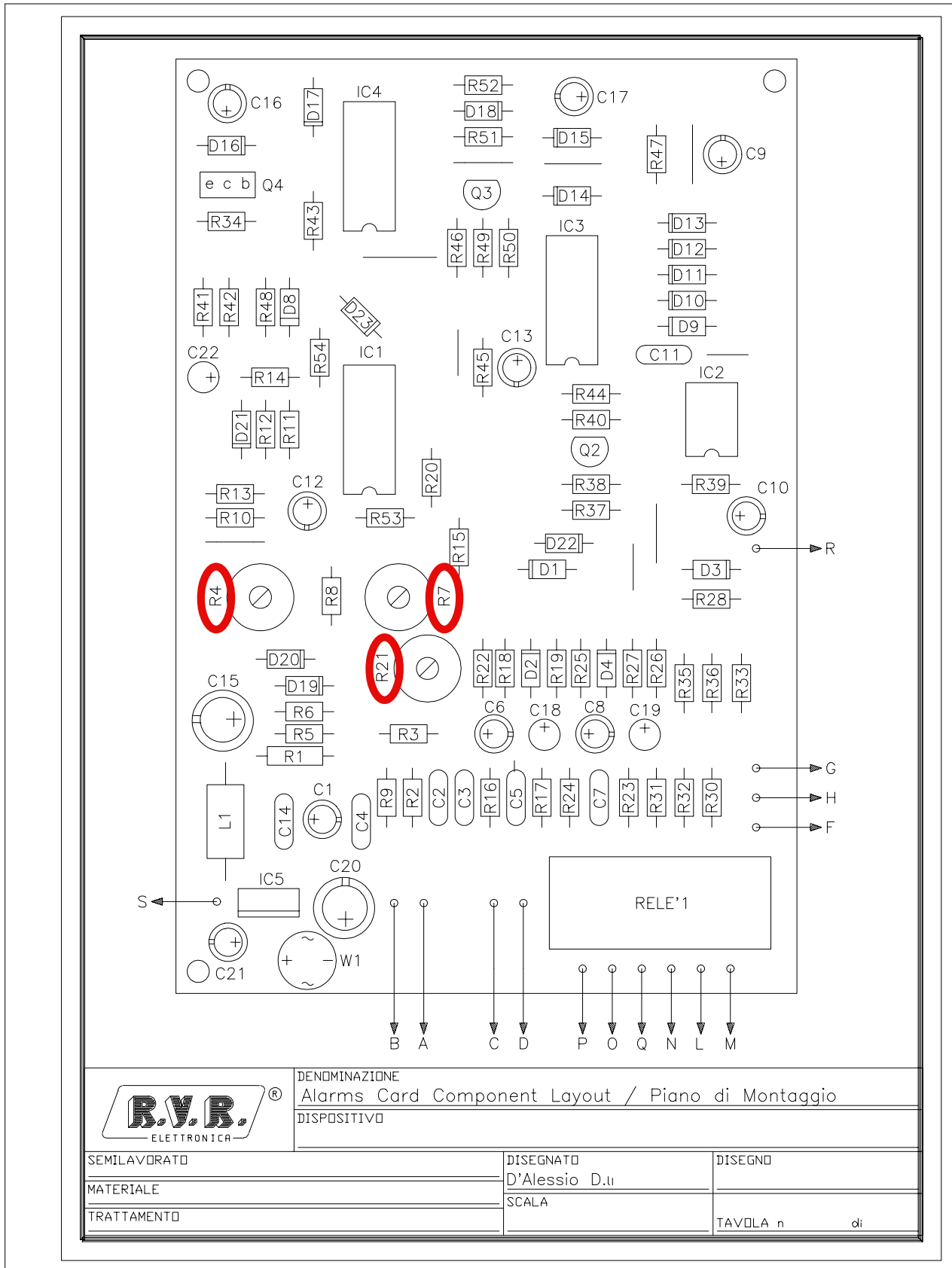
R.V.R. Elettronica S.r.l. (Bo)

Item	Quantity	Reference	Part	Description	Part Order Code
1	1	R3	39#	RESISTOR 2W	RSC002JH0039
2	1	R6	51CH	CHIP RESISTOR	RCC1/4JH0051
3	1	R1	470/10W	RESISTOR 10W	RAF010KH0470
4	2	R4,R5	1K2	RESISTOR 1/4W 5%	RSC1/4JK01,2
5	1	R2	T4K7	TRIMMER REG. VERT. 10mm	RVTD10VK04,7
6	1	C9	225pFRVR	CERAMIC CAP. RVR	CKM225BRVR
7	3	C5,C6,C7	1nF	CERAMIC CAPACITOR	CKM102BK600P
8	1	C1	1nFUNELCO	SILVER MICA CAPACITOR	CSM102XK351
9	1	C10	1nF 5KV	HT CERAMIC CAPACITOR	CHT102B5000V
10	2	C12,C13	47nF	CERAMIC CAPACITOR	CKM473BK600P
11	2	C2,C3	100nF	CERAMIC CAPACITOR	CKM104BK600P
12	1	C8	220nFRVR	CERAMIC CAP. RVR	CKM224BRVR
13	1	C11	0.22µF	POLIESTER CAPACITOR	CPE224DK101
14	1	C4	8µF 450VAC	HIGH VOLTAFE CAPACITOR	CHV0400V0008
15	2	L3,L4	L1210RVR1.2	12SP D.10 RAME S. 1.2mm	BFS12001210
16	1	L5	L1516RVR1.5	15SP D.16 RAME S. 1.5mm	BFS15001516
17	1	L6	L1510RVR1.5	15SP D.10 RAME S.1.5mm	BFS15001510
18	1	L2	L210RVR1.5	2 SP D.10 RAME A. 1.5mm	BFS15000210
19	1	L1	L338RVR1	33SP D. 8 RAME S. 1mm	BFS10003308
20	3	MET1,MET2, MET3	STA100UA	STRUMENTO 100uA	SMABM55RQ101
21	1	HM1	HOURMETH634	H.M. MATSH. TH634 24V	SHMTH634
22	1	CN3	MAMMUT 2P	MORS. MP MONT. DIRET.2P	MORMP2P
23	1	CN1	C.CIR.28PM	CON. CIRC. 28P BULGIN M	CNTBLCCM28P
24	1	CN5	BNC TELAIO	CONN. BNC A TELAIO	CNTBNCFPV
25	1	CN4	BNCMHT	CONN. BNC MAS. PER HT	CNTBNCMHT
26	1	CN2	N CONNECTOR	CONN. N A TELAIO	CNTNFPFL
27	1	CN3	FLANGE 7/8"	FLANGE 7/8"	CNTFL7/8
28	5	SW2,SW3, SW4,SW6,SW7	1V 2P	DEVIATORE 1 VIA 2 POS	DEV1V1103CS
29	1	SW5	1V 2P 0C	DEV. 1 VIA 2 POS 0 CENT	DEV2V1M01M03
30	3	SW4,SW8,SW9	2V 2P 0C	DEV. 2 VIE 2 POS 0 CENT	DEV2V1M01M03
31	1	SW1	SWS1S-I	DEV. FEME 250VAC 15A	DEVSW1S-I
32	1	SW2	SWAHR5411	MICROINT. NAT. AHR5411	DEVAHR5411
33	2	LAMP1,LAMP2	SPIA R07-220V	SPIA AL NEON 220V ROSSA	SPIA07RO220
34	3	DL1,DL2,DL3	LED-R5	RED LED DIODE	LEDRO05

35	2	DL4,DL5	LED-G5	GREEN LED DIODE	LEDVE05
36	1	D1	Z18V	ZENER DIODE 18V 0.4W	DIZ18V0W4
37	1	LIN1	LINEA2	LINEA VJ2000	LINVJ2000
38	1	M1	DC MOTOR1	MOT BUH. 1.61.013.325-W	MOTRCVJ200
39	1	M2	DC MOTOR2	MOT BUH. 1.61.013.330-0	MOTRPVJ200
40	1	Q1	2N3055	NPN SILICON TRANSISTOR	TRN2N3055
41	1	T1	TRF. FIL2	TRF. 220/5V 60VA	TRFFILVJ2000
42	1	FAN1	BLOWER EBM2	VENT. EBM G2E180AA0301	VTLEBMG2E180
43	1	V1	3CX1500	VALV. 3CX1500 EIMAC TR.	VAL3CX1500

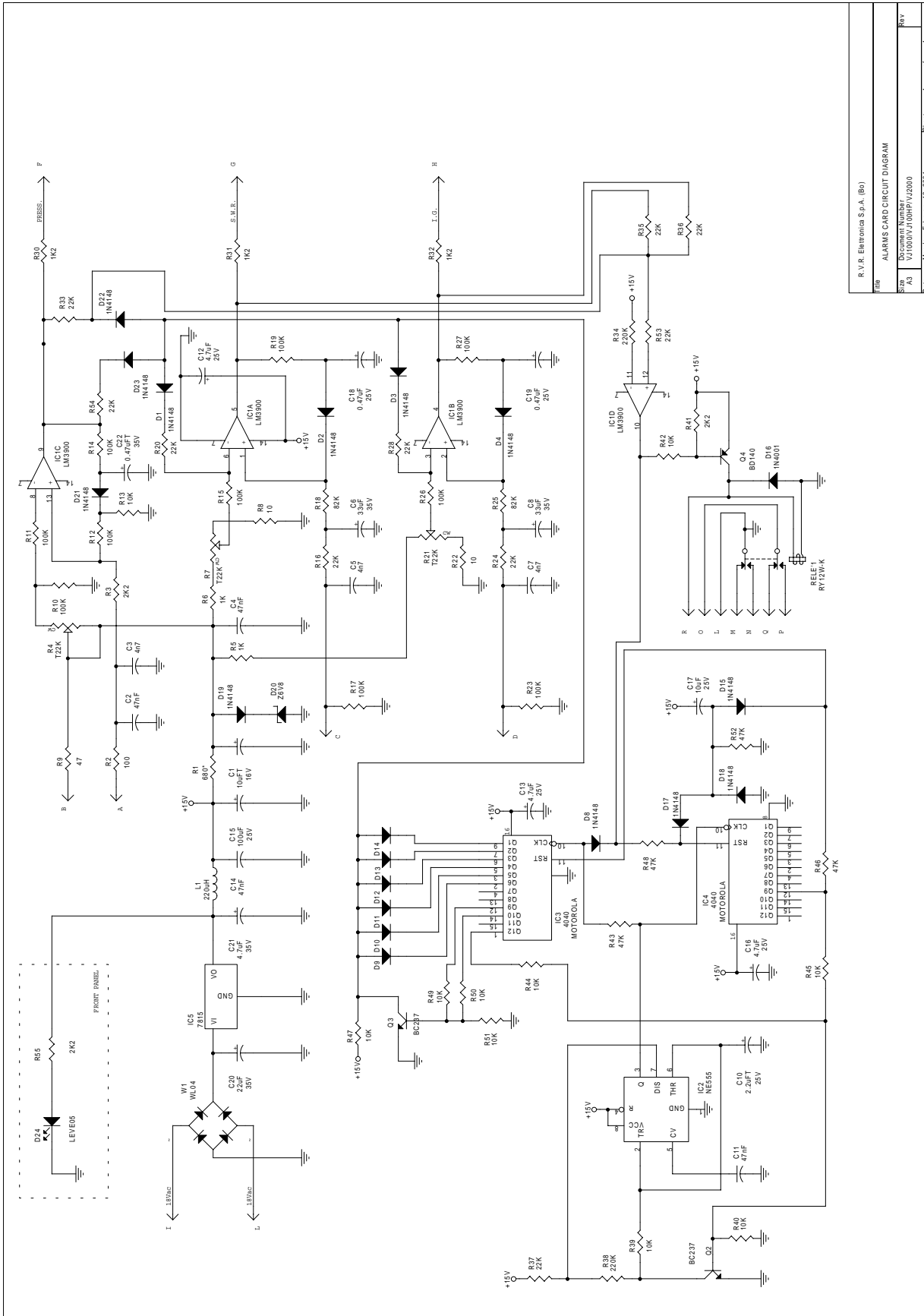
Pagina lasciata intenzionalmente in bianco

This page was intentionally left blank



	DENOMINAZIONE	
	Alarms Card Component Layout / Piano di Montaggio	
	DISPOSITIVO	
SEMILAVORATO	DISEGNATO	DISEGNO
MATERIALE	D'Alessio D.li	
TRATTAMENTO	SCALA	TAVOLA n di

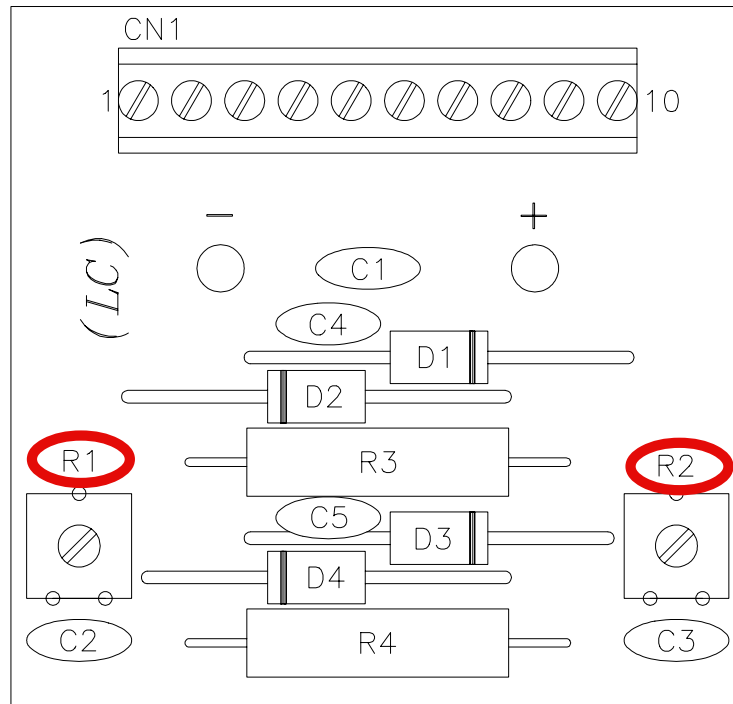
R4	Taratura della Pressione della Turbina // Calibration of the Fan Pressure Alarm Threshold	p.31
R7	Taratura del R.O.S. // Calibration of the V.S.W.R.	p.31
R21	Taratura dell'Intervento della Protezione della Corrente di Griglia // Calibration of the Grid Current Alarm Threshold	p.32




R.V.R. Elettronica S.p.A. (Bo)	
Rev	ALARMS CARD CIRCUIT DIAGRAM
Size	Document Number
A3	VJ1000V/J100HP/J2000
Date	Monday, February 12, 2001
Sheet	1 of 1

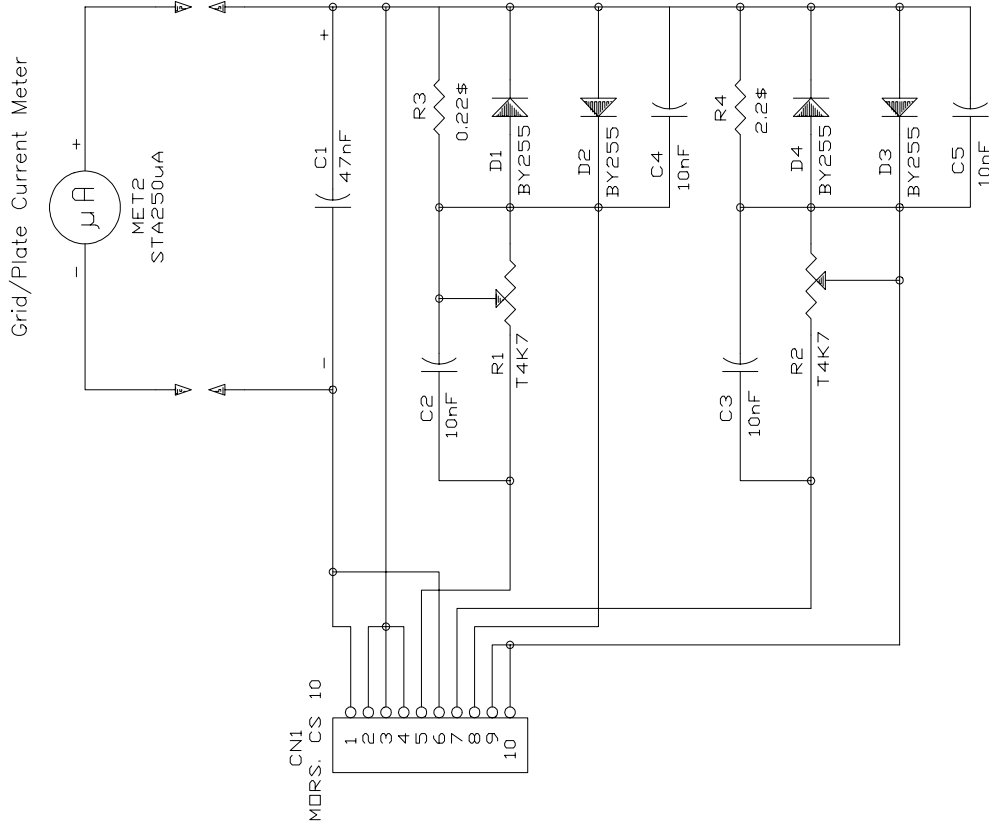
Item	Quantity	Reference	Part	Description	Part Order Code
1	2	R8, R22	10	RESISTOR 1/4W 5%	RSC1/4JH0010
2	1	R9	47	RESISTOR 1/4W 5%	RSC1/4JH0047
3	1	R2	100	RESISTOR 1/4W 5%	RSC1/4JH0100
4	1	R1	680*	RESISTOR 1/2W 5%	RSC1/2JH0680
5	2	R5, R6	1K	RESISTOR 1/4W 5%	RSC1/4JK0001
6	3	R30, R31, R32	1K2	RESISTOR 1/4W 5%	RSC1/4JK01, 2
7	3	R3, R55, R41	2K2	RESISTOR 1/4W 5%	RSC1/4JK02, 2
8	10	R13, R39, R40, R42, R44, R45, R47, R49, R50, R51	10K	RESISTOR 1/4W 5%	RSC1/4JK0010
9	10	R16, R20, R24, R28, R33, R35, R36, R37, R53, R54	22K	RESISTOR 1/4W 5%	RSC1/4JK0022
10	4	R43, R46, R48, R52	47K	RESISTOR 1/4W 5%	RSC1/4JK0047
11	2	R18, R25	82K	RESISTOR 1/4W 5%	RSC1/4JK0082
12	10	R10, R11, R12, R14, R15, R17, R19, R23, R26, R27	100K	RESISTOR 1/4W 5%	RSC1/4JK0100
13	2	R34, R38	220K	RESISTOR 1/4W 5%	RSC1/4JK0220
14	3	R4, R7, R21	T22K	TRIMMER REG. VERT. 10mm	RVTD10VK0022
15	3	C3, C5, C7	4n7	CERAMIC CAPACITOR	CKM472BK600P
16	4	C2, C4, C11, C14	47nF	CERAMIC CAPACITOR	CKM473BK600P
17	2	C18, C19	0.47µF	POLYESTER CAPACITOR	CPE474EK101
18	1	C22	0.47µFT	TANTALIUM CAPACITOR	CET474AM350
19	1	C10	2.2µFT	TANTALIUM CAPACITOR	CET225AM350
20	4	C12, C13, C16, C21	4.7µF	ELECTROLYTIC CAPACITOR	CEA475AM350
21	1	C17	10µF	ELECTROLYTIC CAPACITOR	CEA106AM350
22	1	C1	10µFT	TANTALIUM CAPACITOR	CET106AM350
23	1	C20	22µF	ELECTROLYTIC CAPACITOR	CEA226BM350
24	2	C6, C8	33µF	ELECTROLYTIC CAPACITOR	CEA336BM350
25	1	C15	100µF	ELECTROLYTIC CAPACITOR	CEA107BM350
26	1	L1	220µH	RF CHOKE	IMP220UA
27	1	RELE'1	RY12W-K	RELAY 2V 12V TAKAMISAWA	RLDRY12W-K

28	18	D1, D2, D3, D4, D8, D9, D10, D11, D12, D13, D14, D15, D17, D18, D19, D21, D22, D23	1N4148	SILICON DIODE	DIS1N4148
29	1	D16	1N4001	SILICON DIODE 50V	DIS1N4001
30	1	W1	WL04	DIODE BRIDGE 1.5A	PNRWL04
31	1	D20	Z6V8	ZENER DIODE 6.8V 0.4W	DIZ6V80W4
32	1	IC5	7815	POS. STABILIZER 1A	CIL7815P
33	2	Q2, Q3	BC237	NPN TRANSISTOR	TRNBC237
34	1	Q4	BD140	PNP TRANSISTOR	TRNBD140
35	1	IC2	NE555	TIMER	CIL555
36	2	IC3, IC4	4040	CMOS DIVIDER MOTOROLA	CID4040
37	1	IC1	LM3900	NORTON QUAD AMP.	CILLM3900
38	1	D24	LEVE05	DIODE LED GREEN DIA 05	LEDVE05



	DENOMINAZIONE	
	Grid/Plate Current Meter Card Component Layout / Piano di Montaggio	
DISPOSITIVO		
SEMILAVORATO	DISEGNATO	DISEGNO
MATERIALE	D'Alessio D. U.	
TRATTAMENTO	SCALA	TAVOLA n di

R1	Calibrazione della Misura di Corrente Anodica // Calibration of the Anode Current Measurement	p.33
R2	Calibrazione della Misura Corrente di Griglia // Calibration of the Grid Current Measurement	p.33



- CN1 1 Connected to a Contact Current Meter Switch
- CN1 2 Connected to D Contact Alarms Card
- CN1 3 Connected to A Contact R.F. Cavity
- CN1 4 Not Connected
- CN1 5 Connected to b Contact Current Meter Switch
- CN1 6 Not Connected
- CN1 7 Connected to c Contact Current Meter Switch
- CN1 8 Connected to K Contact Power Supply Connector
- CN1 9 Not Connected
- CN1 10 Connected to J Contact Power Supply Connector

IA = Corrente Anodica = Plate Current
 IG = Corrente di Griglia = Grid Current

R.V.R. Elettronica S.r.l. (Bo)

Title Ia-Ig Meter Card Circuit Diagram

Size	Document Number	REV
A4		
Date:	August 16, 1994	Sheet
		of

Ia-Ig Meter Card

Bill of Materials/Lista Componenti

Pag. 1

Item	Quantity	Reference	Part	Description	Part Order Code
1	1	R3	0.22\$	RESISTOR 5W	RAF005JH0,22
2	1	R4	2.2\$	RESISTOR 5W	RAF005JH02,2
3	2	R1,R2	T4K7	TRIMMER REG. VERT. 10mm	RVTD10VK04,7
4	4	C2,C3,C4,C5	10nF	CERAMIC CAPACITOR	CKM103BK600P
5	1	C1	47nF	CERAMIC CAPACITOR	CKM473BK600P
6	1	MET2	STA250µA	STRUMENTO 250µA	SMABM55RQ251
7	1	CN1	MORS.CS 10	MORS. CS 10 CONT.	MORSLB10PPO
8	4	D1,D2,D3,D4	BY255	SILICON DIODE 1000V 3A	DISBY255

Pagina lasciata intenzionalmente in bianco

This page was intentionally left blank

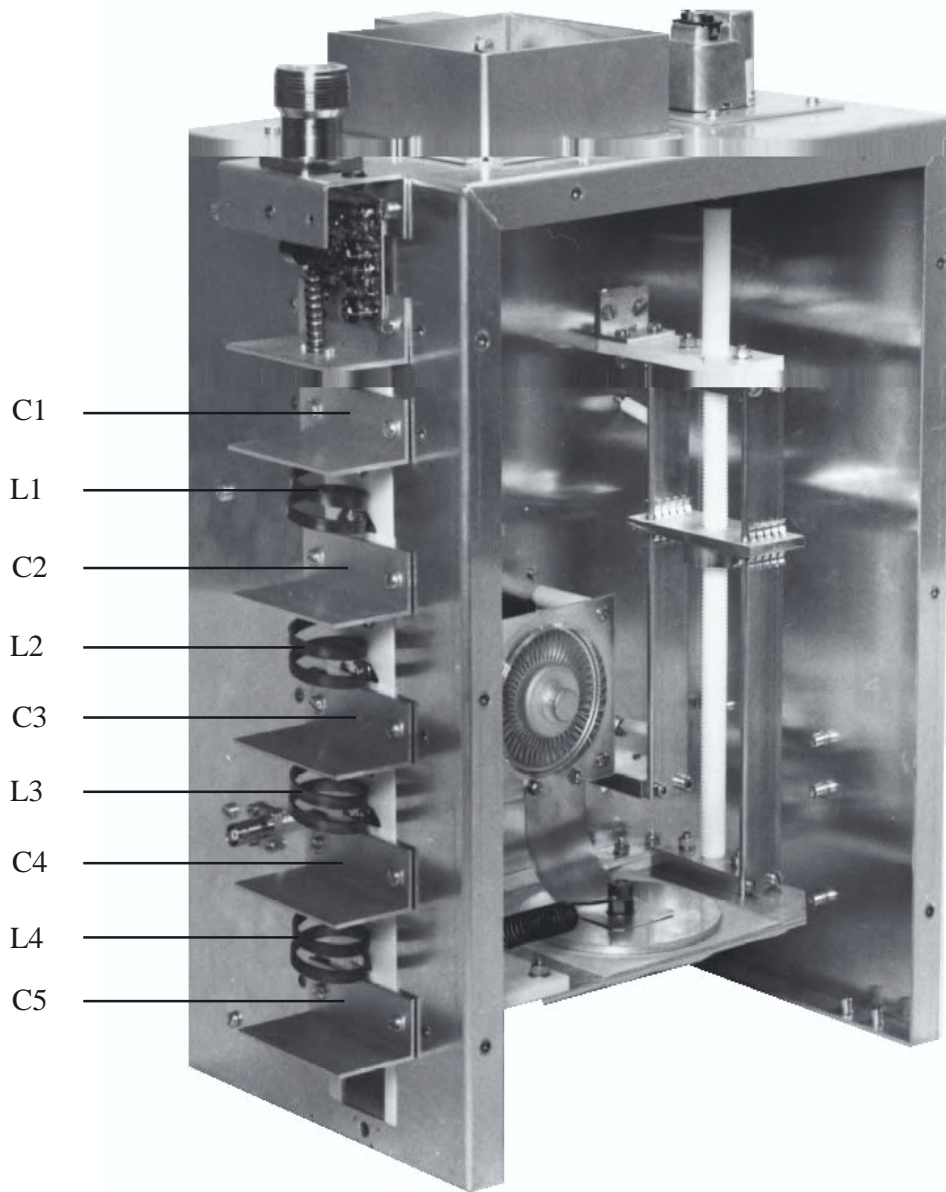
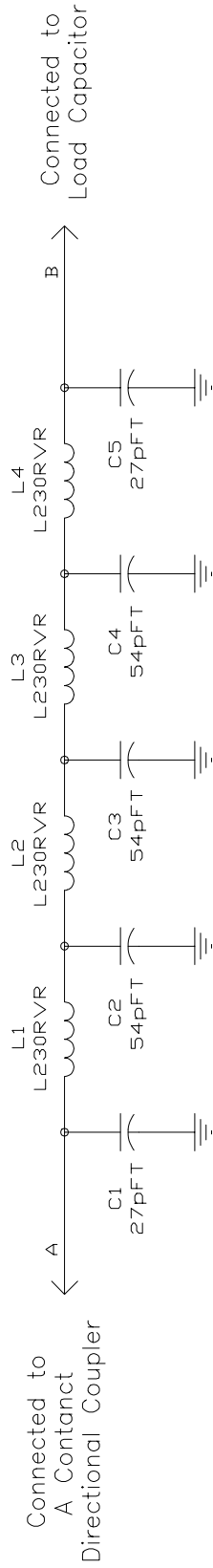


PHOTO 5 / FOTO 5



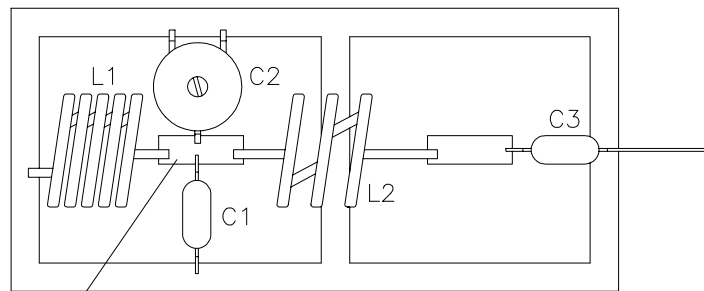
Title		R.V.R. Elettronica S.r.l. (Bo)	
Size		A4	
Document Number		REV	
Date:	Sheet	of	

*Low Pass Filter**Bill of Materials/Lista Componenti**Pag. 1*

<i>Item</i>	<i>Quantity</i>	<i>Reference</i>	<i>Part</i>	<i>Description</i>	<i>Part Order Code</i>
1	2	C1, C5	27pFT	COND. BAND RAME TEFLON	CBRT270RVR
2	3	C2, C3, C4	54pFT	COND. BAND RAME TEFLON	CBRT540RVR
3	4	L1, L2, L3, L4	L230RVR	2 SP DIA 30 BAND. RAME	BBR5000230


Pagina lasciata intenzionalmente in bianco

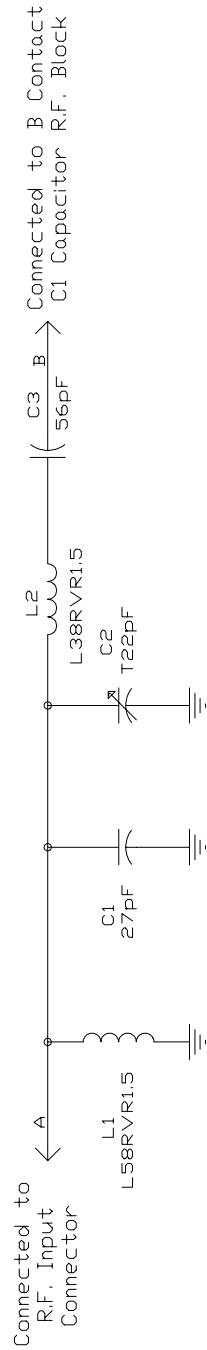
This page was intentionally left blank



Connected to
R.F. Input
Connector

Connected to
B Contact
C1 Capacitor
R.F. Block

	DENOMINAZIONE	
	Input Matching Circuit Component Layout / Piano di Montaggio	
DISPOSITIVO		
SEMILAVORATO	DISEGNATO	DISEGNO
MATERIALE	D'Alessio D.ti	
TRATTAMENTO	SCALA	
	TAVOLA n	di

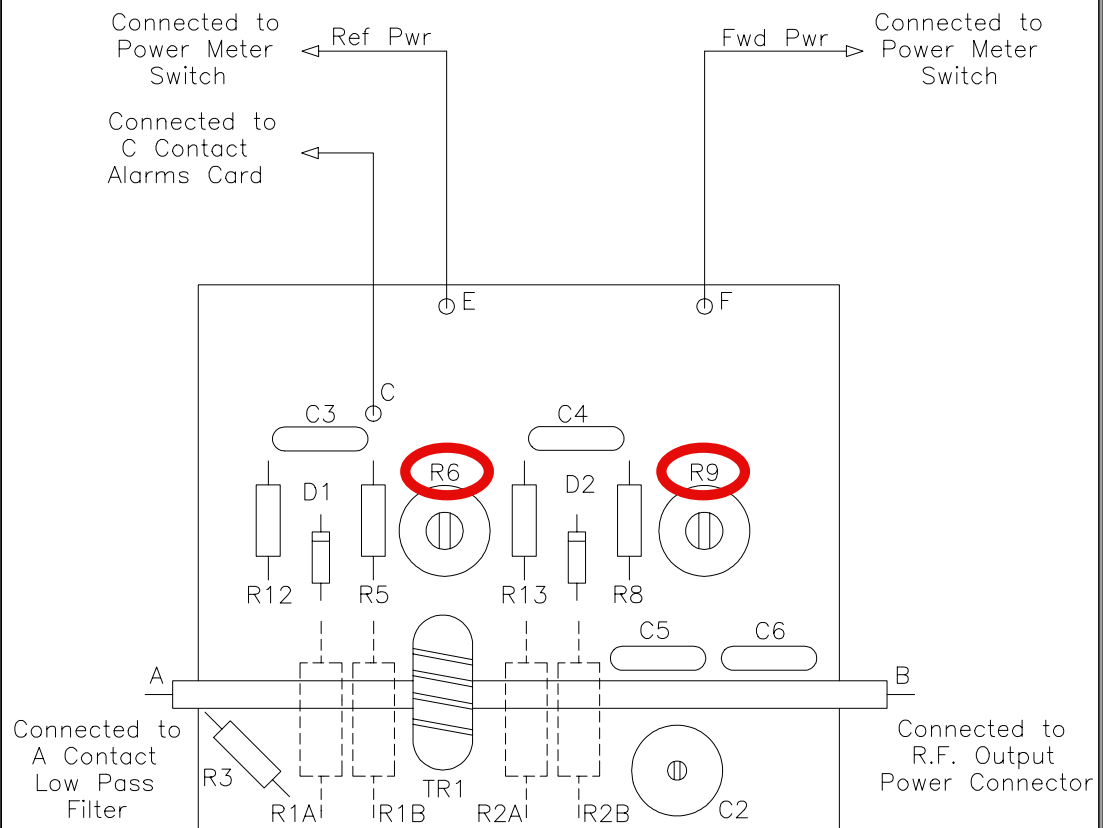


Title		R.V.R. Elettronica S.r.l. (Bo)	
Size		A4	
Document Number		REV	
Date:		Sheet	of

<i>Item</i>	<i>Quantity</i>	<i>Reference</i>	<i>Part</i>	<i>Description</i>	<i>Part Order Code</i>
1	1	C2	T22pF	TRIMMER CAPACITOR	CVF220CK600
2	1	C1	27pF	CERAMIC CAPACITOR NP0	CKM270BJ600C
3	1	C3	56pF	CERAMIC CAPACITOR NP0	CKM560BJ600C
4	1	L1	L58RVR1.5	5 SP DIA 8 R. AR. 1.5mm	BFS15000508
5	1	L2	L38RVR1.5	3 SP DIA 8 R. AR. 1.5mm	BFS15000308

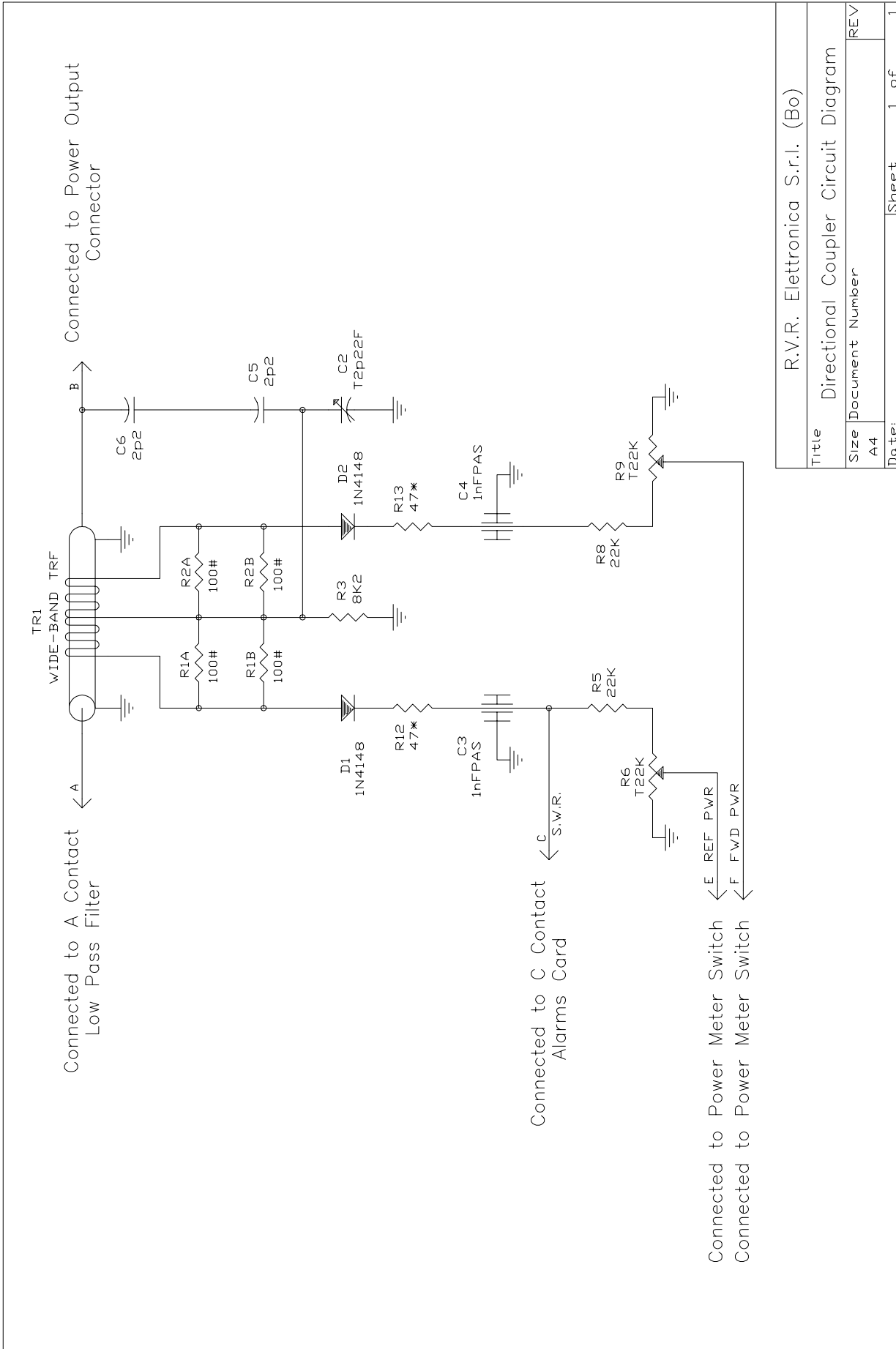
Pagina lasciata intenzionalmente in bianco

This page was intentionally left blank



	DENOMINAZIONE	
	Directional Coupler Card Layout / Piano di Montaggio	
	DISPOSITIVO	
SEMILAVORATO	DISEGNATO	DISEGNO
MATERIALE	D'Alessio D.ii	
TRATTAMENTO	SCALA	TAVOLA n 1 di 1

R6	Calibrazione della Lettura della Potenza Riflessa // Calibration of the Measurement of the Reflected Power	p.32
R9	Calibrazione della Lettura della Potenza Diretta // Calibration of the Measurement of the Forward Power	p.32



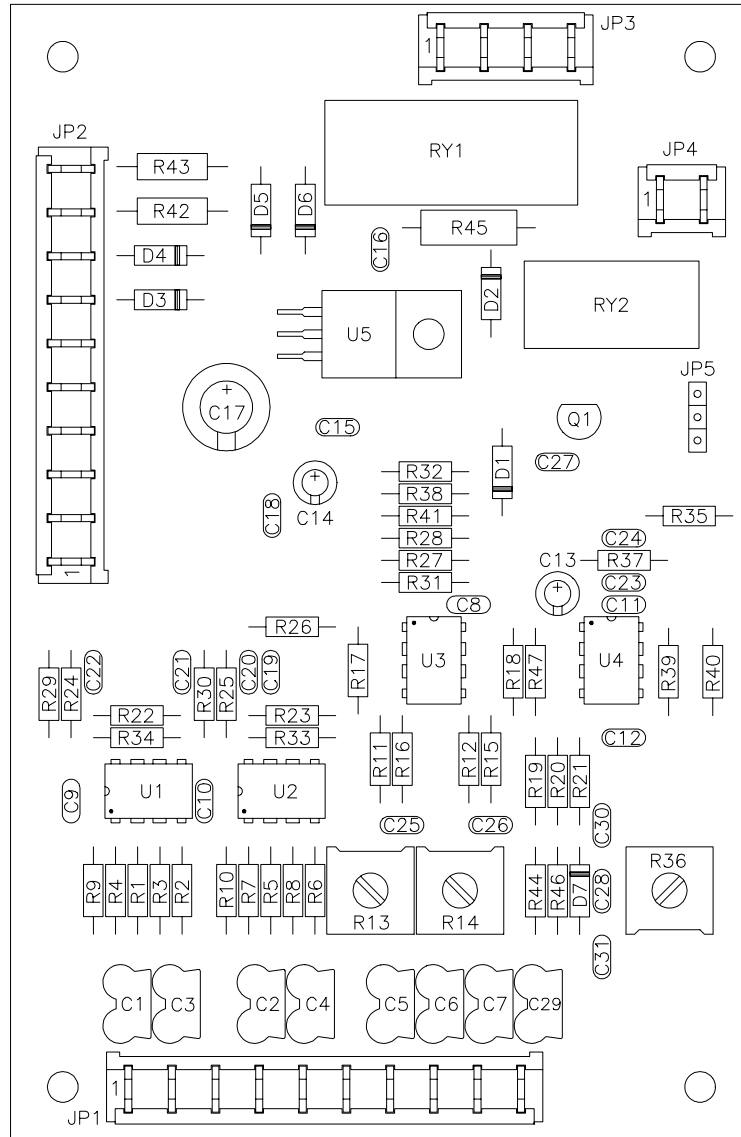
Title		R.V.R. Elettronica S.r.l. (Bo)
Size		A4
Document Number		REV
Date:	Sheet	1 of 1

Directional Coupler Bill of Materials/Lista Componenti Pag. 1

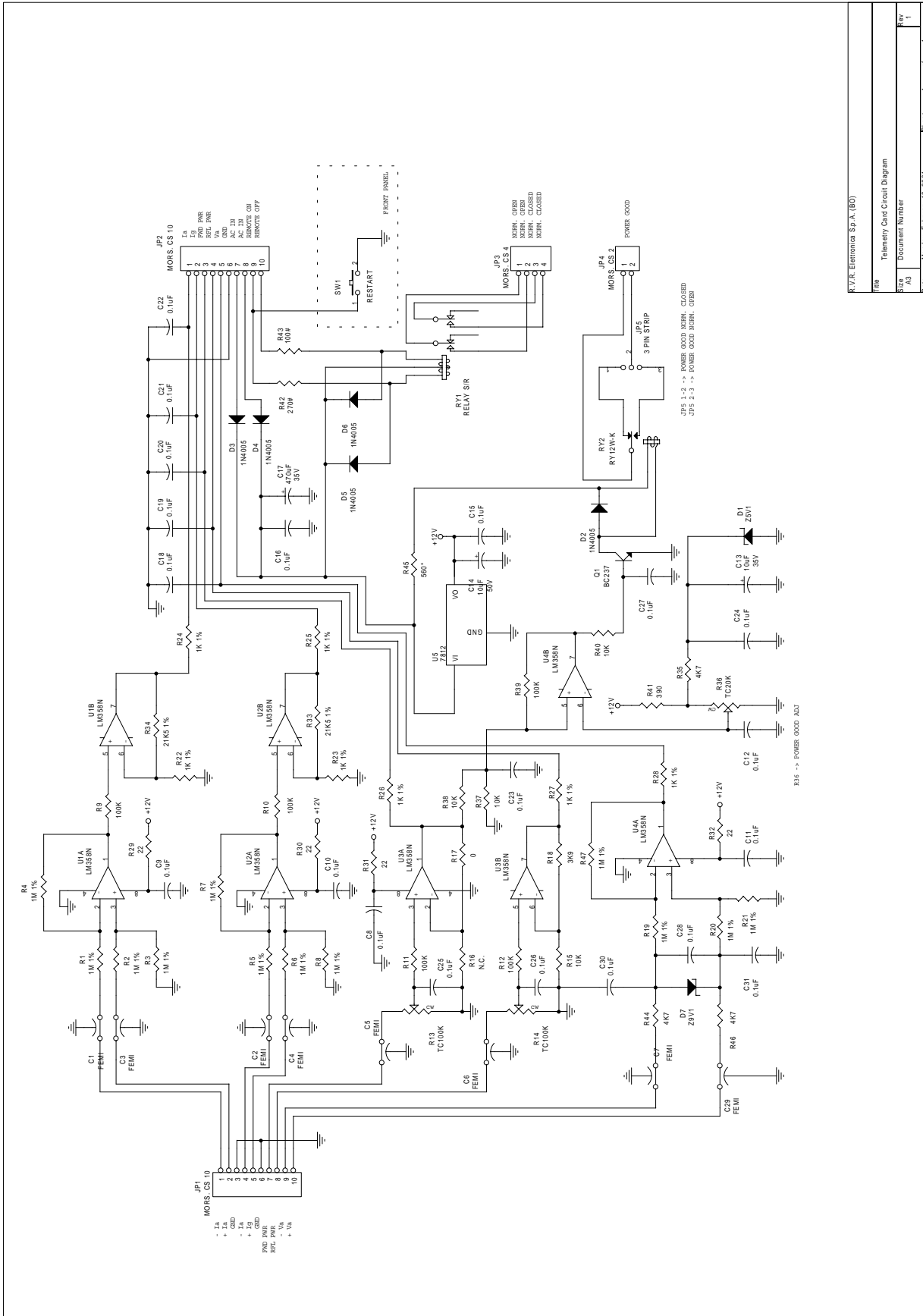
Item	Quantity	Reference	Part	Description	Part Order Code
1	2	R12, R13	47*	RESISTOR 1/2W 5%	RSC1/2JH0047
2	4	R1A, R1B, R2A, R2B	100#	RESISTOR 2W	RSC002JH0100
3	1	R3	8K2	RESISTOR 1/4W 5%	RSC1/4JK08,2
4	2	R5, R8	22K	RESISTOR 1/4W 5%	RSC1/4JK0022
5	2	R6, R9	T22K	TRIM. REG. VERT. 10mm	RVTD10VK0022
6	2	C5, C6	2p2	CERAMIC CAPACITOR NP0	CKM2,2BJ600C
7	1	C2	T2p22F	TRIMMER CAPACITOR	CVC2,22CK600
8	2	C3, C4	1nFPAS	CERAMIC THROUGH CAP.	CDP102XK500
9	2	D1, D2	1N4148	SILICON DIODE	DIS1N4148
10	1	TR1	WIDEBAND TR	WIDE-BAND TRANSFORMER TRFWIDEBAND	

Pagina lasciata intenzionalmente in bianco

This page was intentionally left blank



	DENOMINAZIONE Telemetry Card Component Layout / Piano di Montaggio	
	DISPOSITIVO	
SEMILAVORATO	DISEGNATO D'Alessio D. U	DISEGNO
MATERIALE	SCALA	TAVOLA n di
TRATTAMENTO		



R.V.R. Elettronica S.p.A. (BO)

File: Telemetry Card Circuit Diagram

Size: A3

Document Number:

Date: Monday, February 12, 2001

Sheet 1 of 1

Item	Quantity	Reference	Part	Description	Part Order Code
1	1	R17	0	0 OHM RESISTOR	R000
2	4	R29, R30, R31, R32	22	RESISTOR 1/4W 5%	RSC1/4JH0022
3	1	R43	100#	RESISTOR 2W	RSC002JH0100
4	1	R42	270#	RESISTOR 2W 5%	RSC002JH0270
5	1	R41	390	RESISTOR 1/4W 5%	RSC1/4JH0390
6	1	R45	560*	RESISTOR 1/2W 5%	RSC1/2JH0560
7	7	R22, R23, R24, R25, R26, R27, R28	1K 1%	RESISTOR 1/4W 1%	RSM1/4FK0001
8	1	R18	3K9	RESISTOR 1/4W 5%	RSC1/4JK03,9
9	3	R35, R44, R46	4K7	RESISTOR 1/4W 5%	RSC1/4JK04,7
10	4	R15, R37, R38, R40	10K	RESISTOR 1/4W 5%	RSC1/4JK0010
11	2	R33, R34	21K5 1%	RESISTOR 1/4W 1%	RSM1/4FK21,5
12	5	R9, R10, R11, R12, R39	100K	RESISTOR 1/4W 5%	RSC1/4JK0100
13	12	R1, R2, R3, R4, R5, R6, R7, R8, R19, R20, R21, R47	1M 1%	RESISTOR 1/4W 1%	RSM1/4FM0001
14	1	R36	TC20K	TRIM. REG. VERT. CERMET	RVTVERVK0020
15	2	R13, R14	TC100K	TRIM. REG. VERT. CERMET	RVTCERVK0100
16	20	C8, C9, C10, C11, C12, C15, C16, C18, C19, C20, C21, C22, C23, C24, C25, C26, C27, C28, C30, C31	0.1µF	CERAMIC CAPACITOR	CKM104BK600P
17	2	C13, C14	10µF	ELECTROLYTIC CAPACITOR	CEA106AM350
18	1	C17	470µF	ELECTROLYTIC CAPACITOR	CEA477BM350
19	1	JP5	3 PIN	STRIPSTRIP M P 2.54 3 PIN	CNTSTRIPMCS
20	8	C1, C2, C3, C4, C5, C6, C7, C29	FEMI	FILTRO EMI MURATA	FEAY5S223500
21	1	JP4	MORS. CS 2	MORSETTIERA CS 2 CONT	MORSKB02PPO
22	1	JP3	MORS. CS 4	MORSETTIERA CS 4 CONT.	MORSKB04PPO
23	2	JP1, JP2	MORS. CS 10	MORSETTIERA CS 10 CONT.	MORSLB10PPO
24	1	RY2	RY12W-K	RELAY 2V 12 TAKAMISAWA	RLDRY12W-K
25	1	RY1	RELAY S/R	RELAY SET / RESET 12V	RLDMZP-R2

26	5	D2, D3, D4, D5, D6	1N4005	SILICON DIODE 600V	DIS1N4005
27	1	D1	Z5V1	ZENER DIODE 5.1V 0.4W	DIZ5V10W4
28	1	D7	Z9V1	ZENER DIODE 9.1V 0.4W	DIZ9V10W4
29	1	Q1	BC237	NPN TRANSISTOR	TRNBC237
30	4	U1, U2, U3, U4		LM358N DOUBLE OP. AMP.	CILLM358N
31	1	U5	7812	POS. STABILIZER 1A	CIL7812P
32	1	R16	N.C.	NOT CONNECTED	