

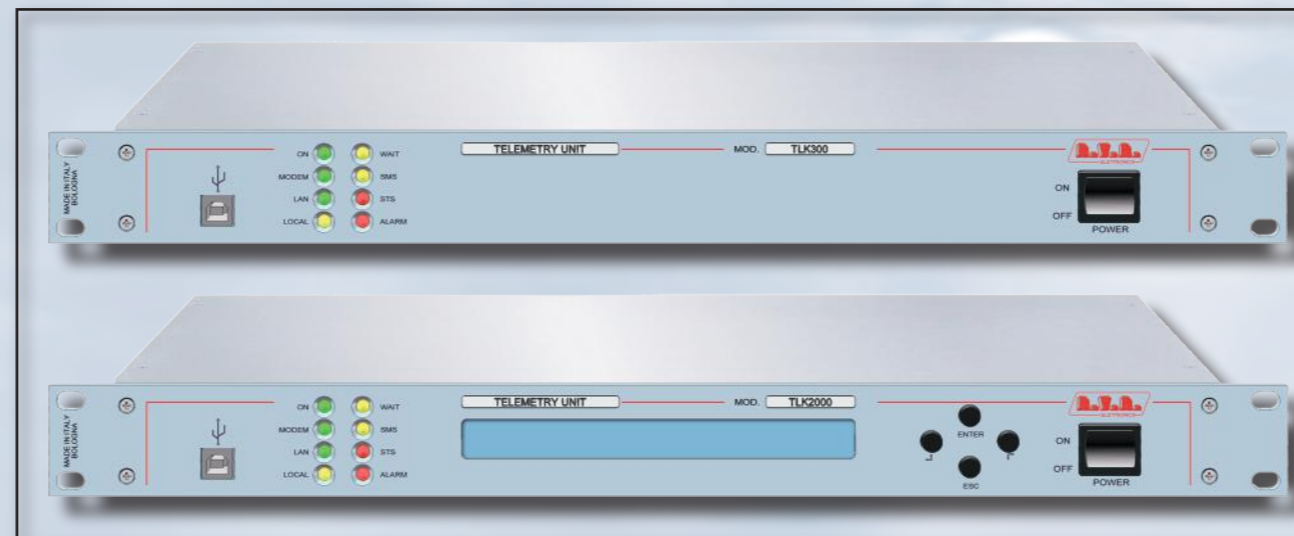

TLK300 & TLK2000

TECHNICAL ANNEX
VOLUME 2



Appendix A Piani di montaggio, schemi elettrici, liste componenti / *Component layouts, schematics, bills of material*

Questa parte del manuale contiene i dettagli tecnici riguardanti la costruzione delle singole schede componenti il TLK300 & TLK2000. L'appendice è composta dalle seguenti sezioni:

This part of the manual contains the technical details about the different Cards of the TLK300 & TLK2000. This appendix is composed of the following sections:

Description	TLK300 vers. RVR Code	TLK2000 vers. RVR Code	Vers.Pages	
Wiring Diagrams	-	/	1.0	1
Wiring Diagrams	/	-	1.0	2
<i>V1, V2, V5 & V6 Version</i>				
Main Card	SLIN0317R03V01	SLIN0317R03V01	1.1	3
16-bit CPU Card	SL034CP1001	SL034CP1001	1.1	7
USB Card	SLIN0026R01V01	SLIN0026R01V01	1.0	11
Panel Card	/	SLPC0320R02V01	1.0	12
<i>V3, V4, V7 & V8 Version</i>				
Main Card	SLIN0317R03V01	SLIN0317R03V01	1.0	3
16-bit CPU Card	SL034CP1001	SL034CP1001	1.0	7
USB Card	SLIN0026R01V01	SLIN0026R01V01	1.0	11
Panel Card	/	SLPC0320R02V01	1.0	12
LAN Card	SL229IN1001	SL229IN1001	1.0	14

Document History

Date	Version	Reason	Code	Editor
29/11/2013	1.0	First Release	/	J.H. Berti

TLK300

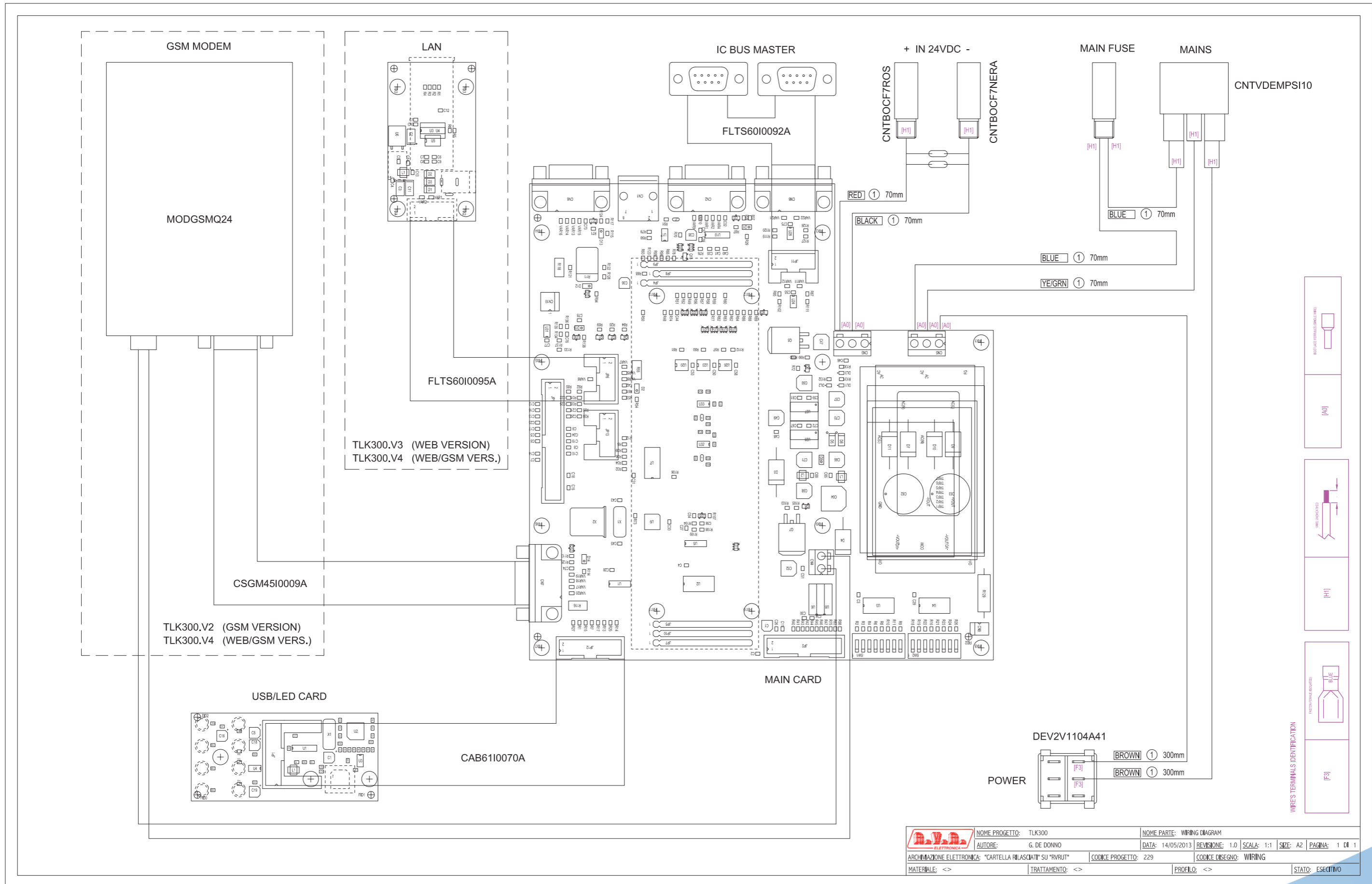

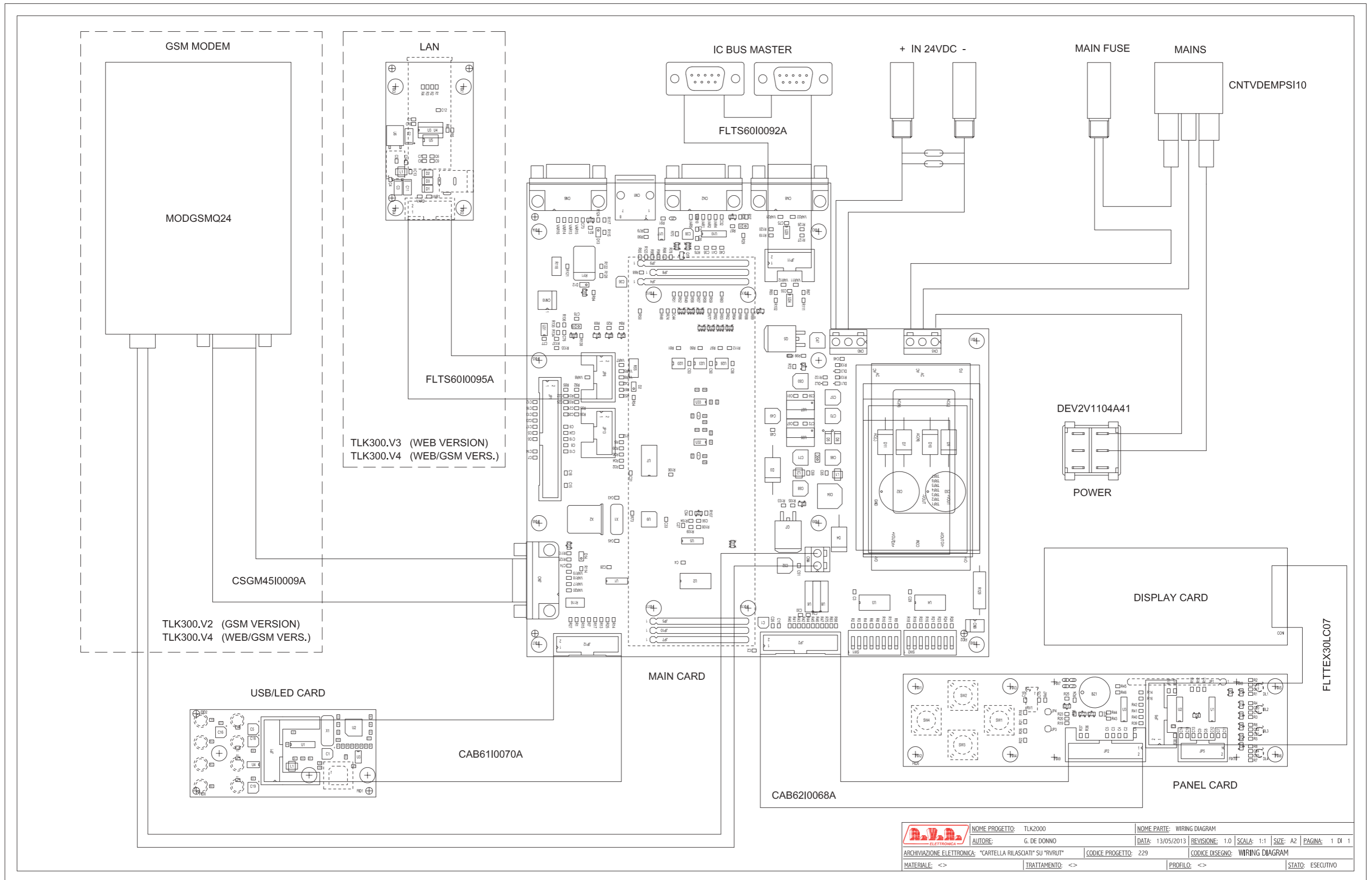

		NOME PROGETTO: TLK300	NOME PARTE: WIRING DIAGRAM
AUTORE: G. DE DONNO		DATA: 14/05/2013	REVISIONE: 1.0
ARCHIVIAZIONE ELETTRONICA: "CARTELLA RILASCIATI" SU "RVRT"		CODICE PROGETTO: 229	SCALA: 1:1
MATERIALE: <>		TRATTAMENTO: <>	PROFILO: <>
		STATO: ESECUTIVO	SIZE: A2
			PAGINA: 1 DI 1

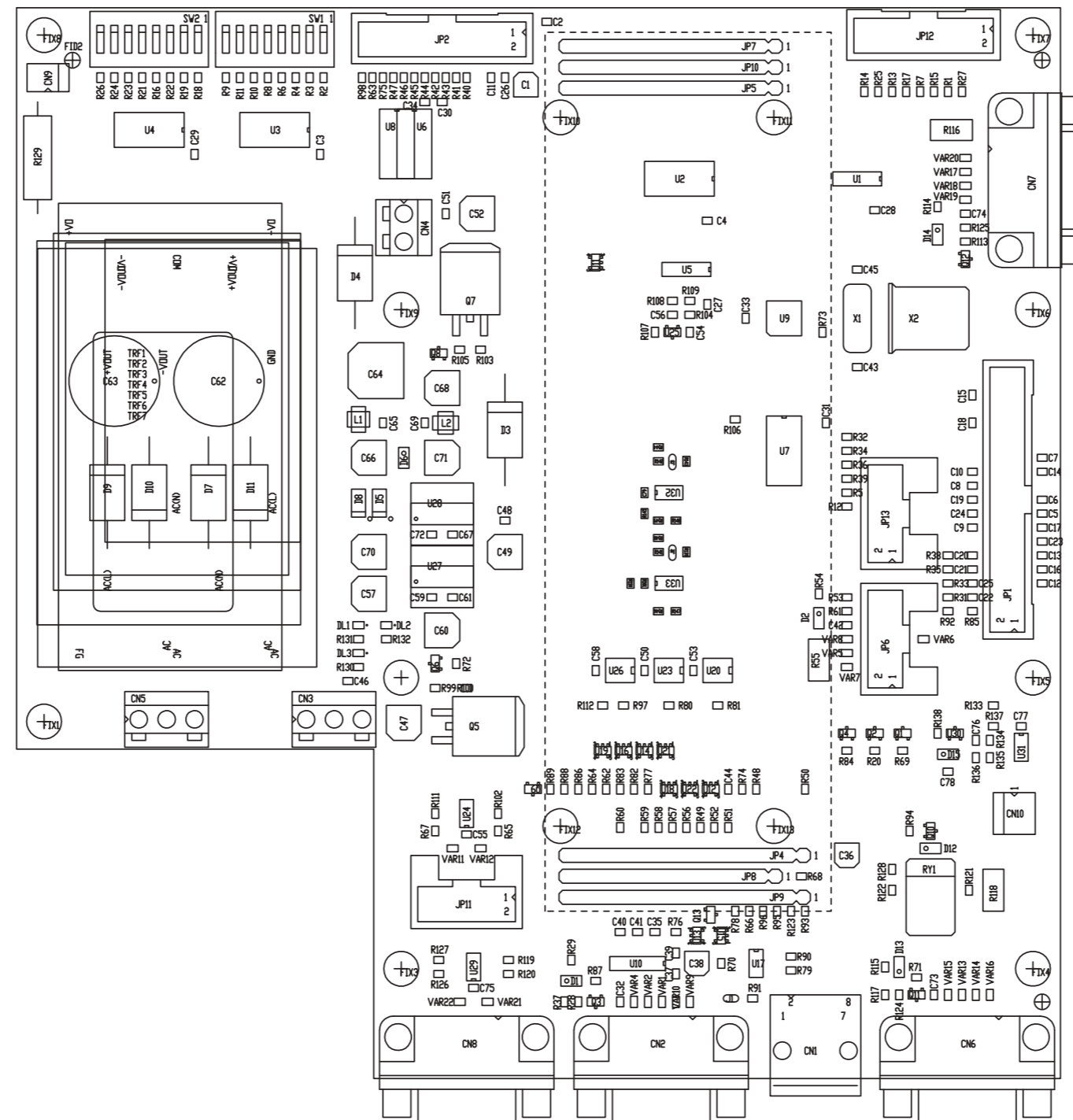

		NOME PROGETTO: TLK2000	NOME PARTE: WIRING DIAGRAM		
AUTORE: G. DE DONNO		DATA: 13/05/2013	REVISIONE: 1.0	SCALA: 1:1	SIZE: A2
ARCHIVIAZIONE ELETTRONICA: "CARTELLA RILASQATI" SU "RVRUT"		CODICE PROGETTO: 229		CODICE DISEGNO: WIRING DIAGRAM	
MATERIALE: <>	TRATTAMENTO: <>	PROFILO: <>	STATO: ESECUTIVO		

SLIN0317R03V01



	NOME PROGETTO: TLK2000	NOME PARTE: MAIN CARD
	AUTORE: TOMMASI / FRANCESCHI	DATA: 02/08/2013 REVISIONE: 1.0 SCALA: 1:1 SIZE: A3 PAGINA: 1 DI 1
ARCHIVIAZIONE ELETTRONICA: \\VRVUT\	CODICE PROGETTO: 229	CODICE DISEGNO: SLIN0317R03V01
MATERIALE: <>	TRATTAMENTO: <>	PROFILO: <>
		STATO: ESECUTIVO

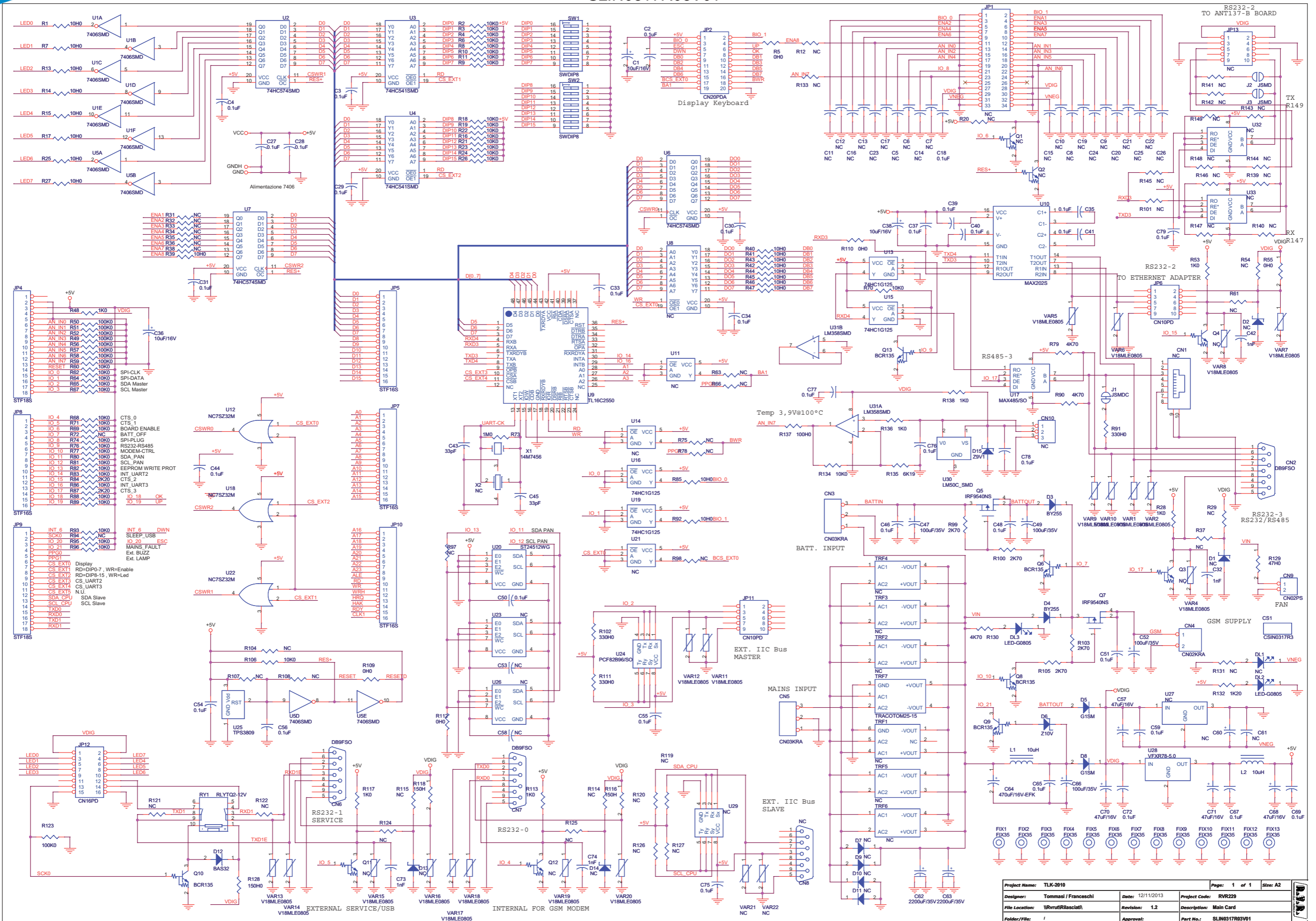

Project Name:	TLK-2010	Date:	12/11/2013	Page:	1 of 1	Size:	A2
Designer:	Tommasi / Franceschi	Revision:	1.2	Project Code:	RVR229		
File Location:	W:\vrr\filasclati	Description:	Main Card				
Folder/File:		Part No.:	SLIN0317R03V01				

SLIN0317R03V01

Main Card Revised: 12/11/2013
 SLIN0317R03V01 Revision: 1.2
 Tommasi / Franceschi
 TLK-2010
 RVR229

Item	Quantity	Reference	Part	Description	Code
1	1	CN1	NC	Connettore RJ45 da CS a 90°	
2	3	CN2,CN6,CN7	DB9FSO	Connettore DB9 femm. cs 90°	CNTDB9FCSA
3	2	CN3,CN5	CN03KRA	Conn. tipo KRA a 3 poli	MORSKRA3
4	1	CN4	CN02KRA	Conn. tipo KRA a 2 poli	MORSKRA2
5	1	CN9	CN02PS	Connettore 2 poli Mascon	CNTMASM2PCS
6	1	CN10	NC	Connettore 3 poli Mascon	
7	1	CS1	CSIN0317R3	Circuito stampato	CSIN0317R3
8	3	C1,C36,C38	10uF/16V	Cond. Elett. SMD d. 4mm	CES106A160
9	34	C2,C3,C4,C18,C27,C28,C29,C30,C31,C33,C34,C35,C37,C39,C40,C41,C44,C46,C48,C50,C51,C54,C55,C56,C59,C65,C67,C69,C72,C75,C76,C77,C78,C79	0.1uF	Cond. SMD 0805	CCC085104KXC
10	24	C5,C6,C7,C8,C9,C10,C11,C12,C13,C14,C15,C16,C17,C19,C20,C21,C22,C23,C24,C25,C26,C53,C58,C61	NC	Cond. SMD 0805	
11	4	C32,C42,C73,C74	1nF	Cond. SMD 0805	CCC085102JNC
12	2	C43,C45	33pF	Cond. SMD 0805	CCC085330JCC
13	4	C47,C49,C52,C66	100uF/35V	Cond. Elett. SMD d. 6.3mm	CES107E350
14	4	C57,C68,C70,C71	47uF/16V	Cond. Elett. SMD d. 6.3mm	CES476C160
15	1	C60	NC	Cond. Elett. SMD d. 6.3mm	
16	2	C62,C63	NC	Cond. Elett. Dia 16 P5 o 7.5	
17	1	C64	470uF/16V-EFK	Cond. Elett. SMD d. 10mm	CES477F160FK
18	1	DL1	NC	LED Verde SMD 0805	
19	2	DL2,DL3	LED-G0805	LED Verde SMD 0805	LEDV0805
20	4	D1,D2,D13,D14	NC	MINIMELF SMD Zener Diode	
21	2	D3,D4	BY255	Diode plastico DO201	DISBY255
22	2	D5,D8	G15M	MELF SMD Diode	DIS4007SMA
23	1	D6	Z10V	MINIMELF SMD Zener Diode	DIZ10VMINI
24	4	D7,D9,D10,D11	NC	Diode plastico DO201	
25	1	D12	BAS32	MINIMELF SMD Diode	DISBAS32MINI
26	1	D15	Z9V1	MINIMELF SMD Zener Diode	DIZ9V1MINI
27	13	FIX1,FIX2,FIX3,FIX4,FIX5,FIX6,FIX7,FIX8,FIX9,FIX10,FIX11,FIX12,FIX13	FIX35	Foro fissaggio 3.5mm	
28	1	JP1	NC	Connettore 34 poli Flat cs	
29	1	JP2	CN20PDA	Conn.M.C.S.Dritto 20P alette	CNTMCS20A
30	2	JP4,JP9	STF18S	Strip femmina 18 pin	CNTSTF18SDB
31	4	JP5,JP7,JP8,JP10	STF16S	Strip femmina 16 pin	CNTSTF16SDB
32	2	JP6,JP11	CN10PD	Connettore 10 poli Flat cs	CNTMCS10A
33	1	JP12	CN16PD	Conn.M.C.S.Dritto 16P alette.	CNTMCS16A
34	1	JP13	NC	Connettore 10 poli Flat cs	
35	1	J1	JSMDC	Pad SMD a saldare chiuso	
36	2	J2,J3	JSMDC	Pad SMD a saldare	
37	2	L1,L2	10uH	Ind. verticale SMD dia. 4 p 4.8	IMP10USMS50
38	6	Q1,Q2,Q3,Q4,Q11,Q12	NC	Trans./Res. NPN SOT23	
39	2	Q5,Q7	IRF9540NS	Trans. FET P D2PAK	TRNIRF9540NS
40	5	Q6,Q8,Q9,Q10,Q13	BCR135	Trans./Res. NPN SOT23	TRNBCR135
41	1	RY1	RLYTQ2-12V	Rele' TQ2	RLD2V12V05AM

42	19	R1,R7,R13,R14,R15,R17,R25,R27,R39,R40,R41,R42,R43,R44,R45,R46,R47,R85,R92	10H0	Res. SMD 0805 1%	RCH085F0010H
43	40	R2,R3,R4,R6,R8,R9,R10,R11,R16,R18,R19,R21,R22,R23,R24,R26,R60,R62,R64,R65,R67,R68,R69,R70,R71,R74,R76,R77,R80,R81,R82,R83,R86,R88,R89,R93,R95,R96,R106,R134	10K0	Res. SMD 0805 1%	RCH085F0010K
44	4	R5,R109,R110,R112	0H0	Res. SMD 0805 1%	RCH085F0000H
45	48	R12,R20,R29,R31,R32,R33,R34,R35,R36,R37,R38,R54,R61,R63,R66,R72,R75,R78,R94,R97,R98,R101,R104,R107,R108,R114,R115,R119,R120,R121,R122,R124,R125,R126,R127,R131,R133,R139,R140,R141,R142,R143,R144,R145,R146,R147,R148,R149	NC	Res. SMD 0805 1%	
46	7	R28,R48,R53,R113,R117,R136,R138	1K0	Res. SMD 0805 1%	RCH085F0001K
47	9	R49,R50,R51,R52,R56,R57,R58,R59,R123	100K0	Res. SMD 0805 1%	RCH085F0100K
48	1	R55	0H0	Res. SMD 2512 5%	RCH252J0000H
49	3	R116,R118	150H	Res. SMD 2512 5%	RCH252J0150H
50	1	R73	1M0	Res. SMD 0805 1%	RCH085F0001M
51	3	R79,R90,R130	4K70	Res. SMD 0805 1%	RCH085F004K7
52	2	R84,R87	2K20	Res. SMD 0805 1%	RCH085F002K2
53	3	R91,R102,R111	330H0	Res. SMD 0805 1%	RCH085F0330H
54	4	R99,R100,R103,R105	2K70	Res. SMD 0805 1%	RCH085F002K7
55	1	R128	150H0	Res. SMD 0805 1%	RCH085F0150H
56	1	R129	47H0	Res. 1W	RSM002J0047H
57	1	R132	1K20	Res. SMD 0805 1%	RCH085F001K2
58	1	R135	6K19	Res. SMD 0805 1%	RCH085F06K19
59	1	R137	100H0	Res. SMD 0805 1%	RCH085F0100H
60	2	SW1,SW2	SWDIP8	Dip switch 8 vie	DSW8VO
61	1	TRF1	NC	AC-DC Conv. 25W Serie TMS	
62	1	TRF2	NC	AC-DC Conv. 5W	
63	1	TRF3	NC	AC-DC Conv. 5W	
64	1	TRF4	NC	AC-DC Conv. 10W	
65	1	TRF5	NC	AC-DC Conv. 15W	
66	1	TRF6	NC	AC-DC Conv. 20W	
67	1	TRF7	TRACOTOM25-15	AC-DC Conv. 25W Serie TOM	PSSWTOM25115
68	2	U1,U5	7406SMD	Hex inv OC SMD SO14	CID7406S
69	3	U2,U6,U7	74HC574SMD	Octal Latch SMD	CID74HC574S
70	2	U3,U4	74HC541SMD	Octal buffer SMD	CID74HC541SM
71	1	U8	NC	Octal buffer SMD	
72	1	U9	TL16C2550	Dual FIFO Bus UART	CIDTL16C2550
73	1	U10	MAX202S	RS232 Driver SMD SO16	CIDMX202CSES
74	3	U11,U14,U21	NC	SOT23-5 Bus Buffer	
75	3	U12,U18,U22	NC7S232M	SOT23-5 OR Port	CIDNC7S232M5
76	4	U13,U15,U16,U19	74HC1G125	SOT23-5 Bus Buffer	CID74LVC1G125GV
77	1	U17	MAX485/SO	RS485 driver SMD SO8	CIDMAX485CSA
78	1	U20	ST24512WG	IIC Bus 512Kb EEPROM	CIDSTM24512
79	2	U23,U26	NC	IIC Bus 512Kb EEPROM	
80	1	U24	PCF82B96/SO	IIC Bus driver SMD	CID82B96S
81	1	U25	TPS3809	uP supply supervisor	CIDTPS3809
82	1	U27	NC	Switching SIP3 regulator	

SLIN0317R03V01

83	1 U28	VFXR78-5.0	Switching SIP3 regulator	CIL78SW50
84	1 U29	NC	IIC Bus driver SMD	
85	1 U30	LM50C_SMD	Temperature sensor	CILLM50C
86	1 U31	LM358SMD	Dual Op. SMD SO8	CILLM358SMD
87	2 U32,U33	NC	RS485 driver SMD SO8	
88	19 VAR1,VAR2,VAR4,VAR5,VAR6, VAR7,VAR8,VAR9,VAR10, VAR11,VAR12,VAR13,VAR14, VAR15,VAR16,VAR17,VAR18, VAR19,VAR20	V18MLE0805	ESD SMD protector	MOV018V085
89	2 VAR21,VAR22	NC	ESD SMD protector	
90	1 X1	14M7456	Quarzo SMD HC49SMD	QRZ014M7456C
91	1 X2	NC	Quarzo HC25 orizz.	

SL034CP1001

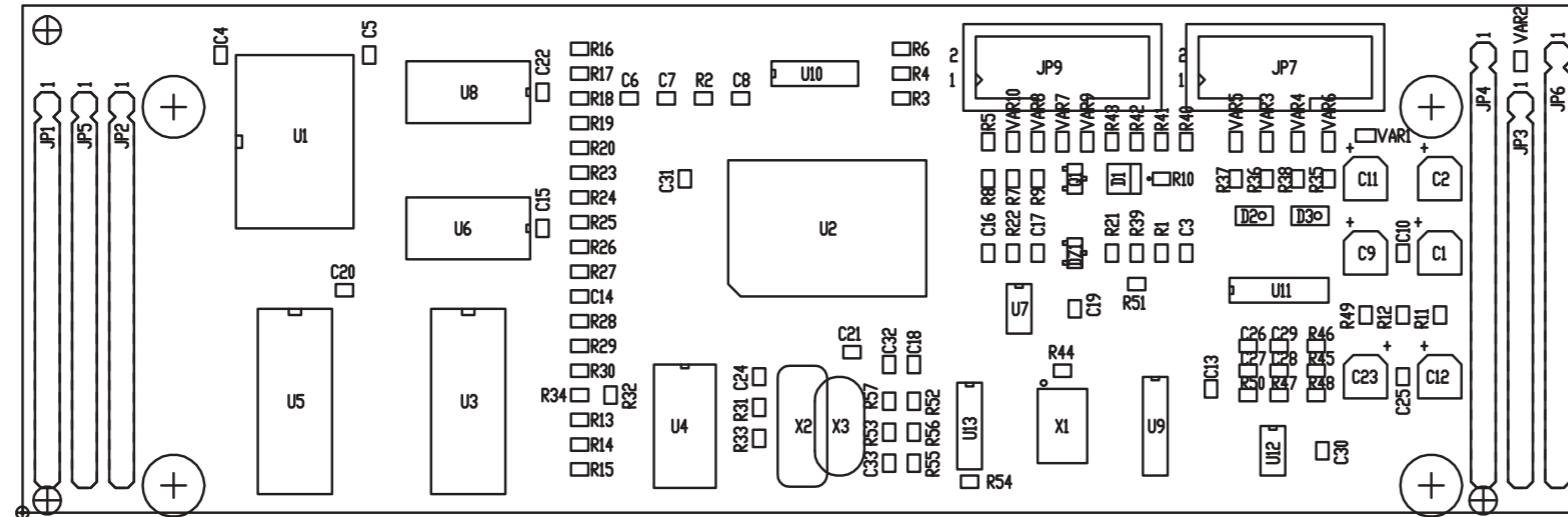

NOME PROGETTO: PTX-LCD		NOME PARTE: CPU 16 BIT CARD	
AUTORE: A. TOMMASI		DATA: 12/02/2004	
ARCHIVIAZIONE ELETTRONICA: \\VRUT1		REVISIONE: 2.1	SCALA: 1:1
MATERIALE:		SIZE: A4	PAGINA: 1 DI 1
TRATTAMENTO:		CODICE DISEGNO: SLCPU16V2R02	
		PROFILO:	STATO: ESECUTIVO

SL034CP1001

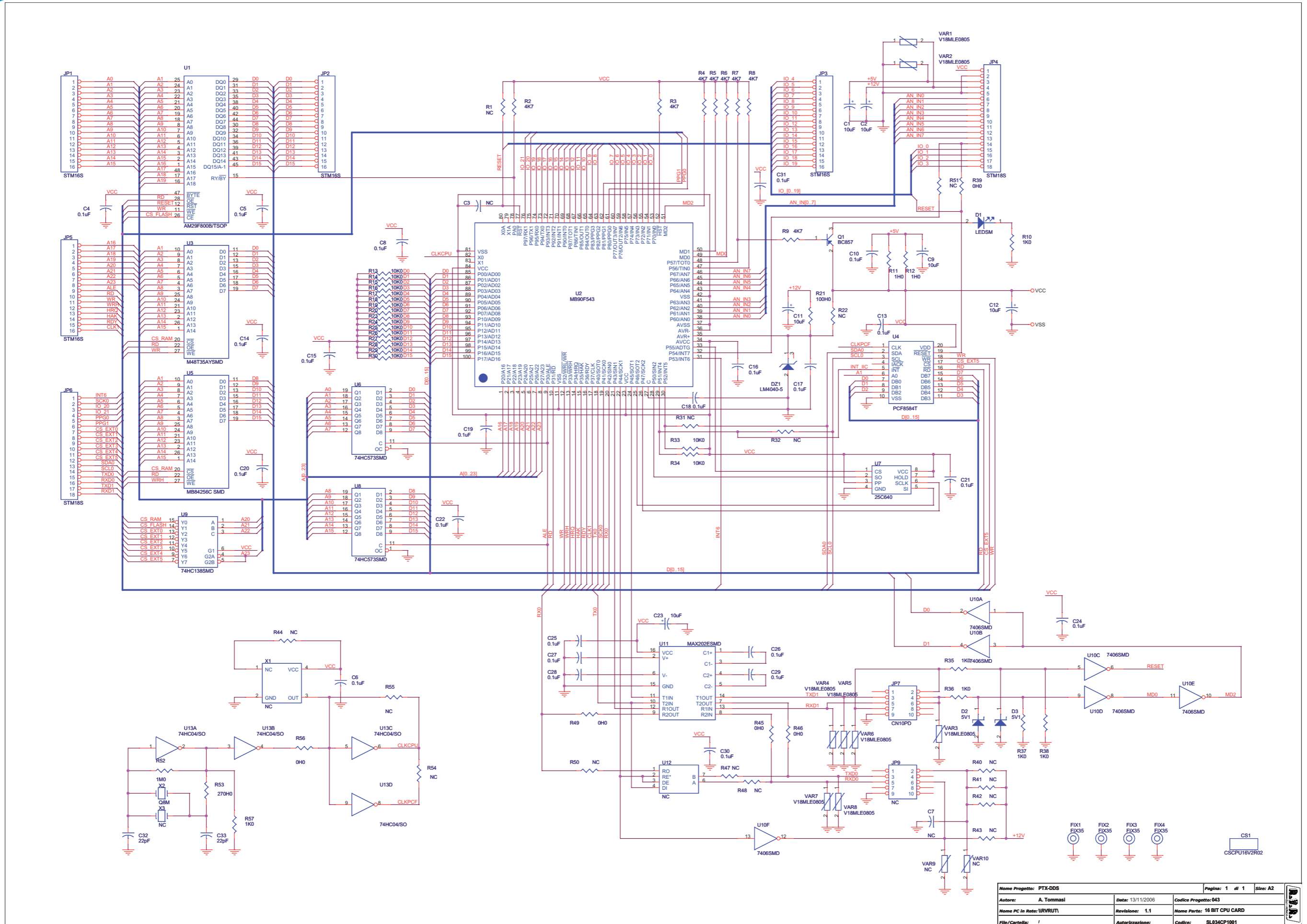

Nome Progetto: PTX-DDS	Data: 13/11/2006	Codice Progetto: 043	Pagina: 1 di 1	Size: A2
Autore: A. Tommasi	Revisione: 1.1	Nome Parte: 16 BIT CPU CARD		
Nome PC in Rete: \RVR\TUT	Autore/Revisione:	Codice: SL034CP1001		
File/Cartella: /				

SL034CP1001

16 BIT CPU CARD - SL034CP1001
 Revision: 1.1 Date: 13/11/2006
 PTX-DDS
 034
 A. Tommasi

Item	Quantity	Reference	Part	Description	Code
1	1	CS1	CSCPU16V2R02	Circuito stampato	CSCPU16V2R02
2	6	C1, C2, C9, C11, C12, C23	10uF	Cond. Elett. SMD d. 4mm	CES106A160
3	2	C3, C7	NC	Cond. SMD 0805	
4	23	C4, C5, C6, C8, C10, C13, C14, C15, C16, C17, C18, C19, C20, C21, C22, C24, C25, C26, C27, C28, C29, C30, C31	0.1uF	Cond. SMD 0805	CCC085104KXC
5	2	C32, C33	22pF	Cond. SMD 0805	CCC085220JCC
6	1	DZ1	LM4040-5	Diodi Zener SMD SOT23	CILLM4040-5
7	1	D1	LEDSM	LED SMD PLCC2	LEDRSMDPLCC2
8	2	D2, D3	5V1	MINIMELF SMD Zener Diode	DIZ5V1MINI
9	4	FIX1, FIX2, FIX3, FIX4	FIX35	Foro fissaggio	
10	4	JP1, JP2, JP3, JP5	STM16S	Strip maschio 16 pin	CNTSTM40SDC
11	2	JP4, JP6	STM18S	Strip maschio 18 pin	CNTSTM40SDC
12	1	JP7	CN10PD	Connettore 10 poli Flat cs	CNTMCS10A
13	1	JP9	NC	Connettore 10 poli Flat cs	
14	1	Q1	BC857	Trans. PNP SOT23	TRNBC857
15	15	R1, R22, R31, R32, R40, R41, R42, R43, R44, R47, R48, R50, R51, R54, R55	NC	Res. SMD 0805	
16	8	R2, R3, R4, R5, R6, R7, R8, R9	4K7	Res. SMD 0805	RCH085F004K7
17	6	R10, R35, R36, R37, R38, R57	1K0	Res. SMD 0805	RCH085F0001K
18	2	R11, R12	1H0	Res. SMD 0805	RCH085F0001H
19	18	R13, R14, R15, R16, R17, R18, R19, R20, R23, R24, R25, R26, R27, R28, R29, R30, R33, R34	10K0	Res. SMD 0805	RCH085F0010K
20	1	R21	100H0	Res. SMD 0805	RCH085F0100H
21	5	R39, R45, R46, R49, R56	0H0	Res. SMD 0805	RCH085F0000H
22	1	R52	1M0	Res. SMD 0805	RCH085F0001M
23	1	R53	270H0	Res. SMD 0805	RCH085F0270H
24	1	U1	AM29F800B/TSOP	Flash Eprom SMD TSOP48	CIDAM29F800B
25	1	U2	MB90F543	QFP100 SMD Microprocessor	CIDMB90F543
26	1	U3	M48T35AYSMD	RAM+RTC with Battery SMD	CIDM48T35Y7S
27	1	U4	PCF8584T	IIC Bus controller SMD	CIDPCF8584SM
28	1	U5	MB84256C SMD	RAM+RTC with Battery SMD	CID76C256
29	2	U6, U8	74HC573SMD	Octal Latch SMD	CID74HC573S
30	1	U7	25C640	Serial EEPROM SMD	CID25C640SN
31	1	U9	74HC138SMD	8 line decoder SMD	CID74HC138S
32	1	U10	7406SMD	Hex inv OC SMD SO14	CID7406S
33	1	U11	MAX202ESMD	RS232 Driver SMD SO16	CIDMX202ESDS
34	1	U12	NC	RS485 driver SMD SO8	
35	1	U13	74HC04/SO	Hex Inv. SMD SO14	CID74HC04S
36	8	VAR1, VAR2, VAR3, VAR4, VAR5, VAR6, VAR7, VAR8	V18MLE0805	ESD SMD protector	MOV018V085
37	2	VAR9, VAR10	NC	ESD SMD protector	
38	1	X1	NC	Osc. quarzo SMD	
39	1	X2	Q8M	Quarzo SMD HC49SMD	QRZ000008MC
40	1	X3	NC	Quarzo HC18	

SLIN0026R01V01

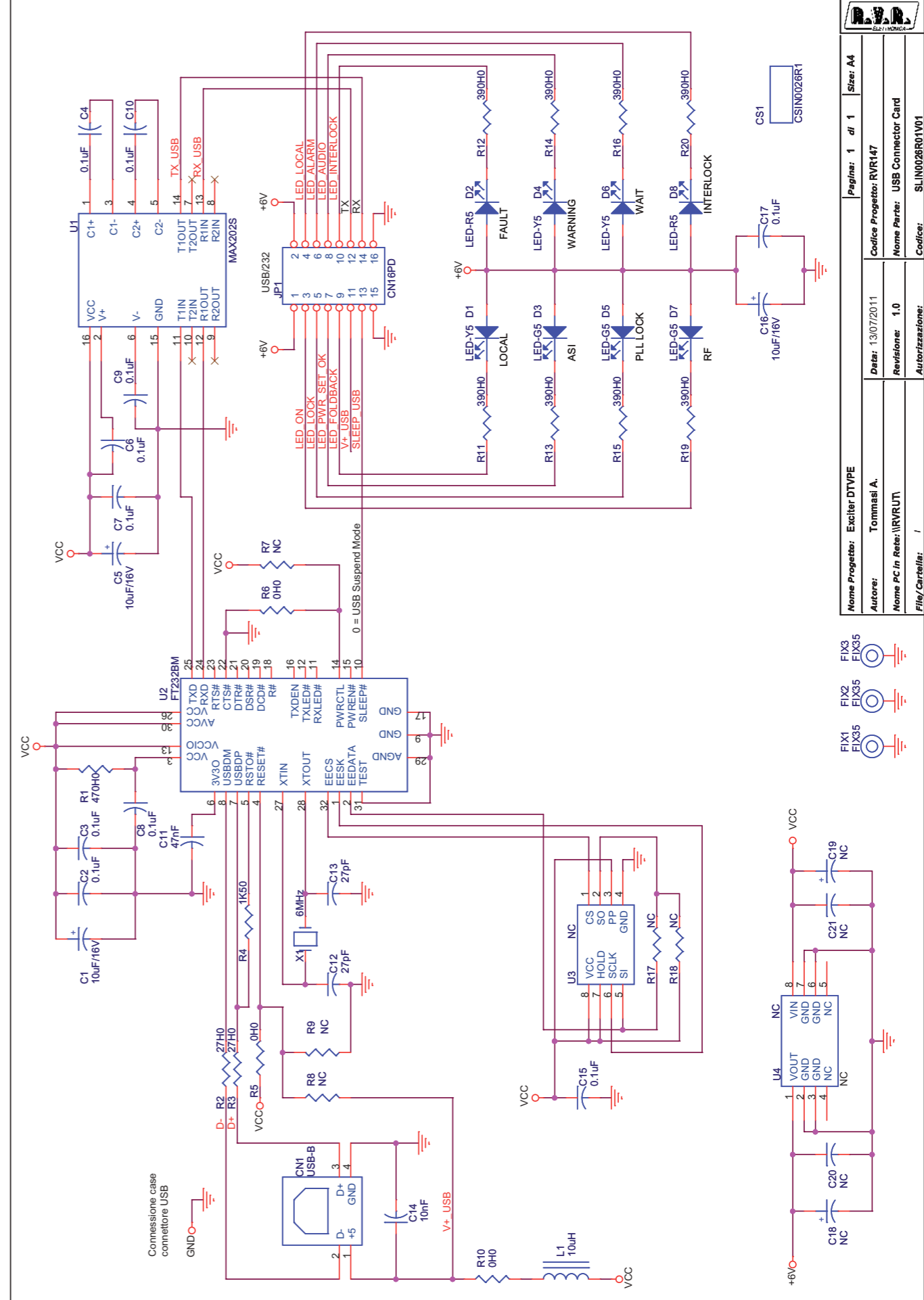
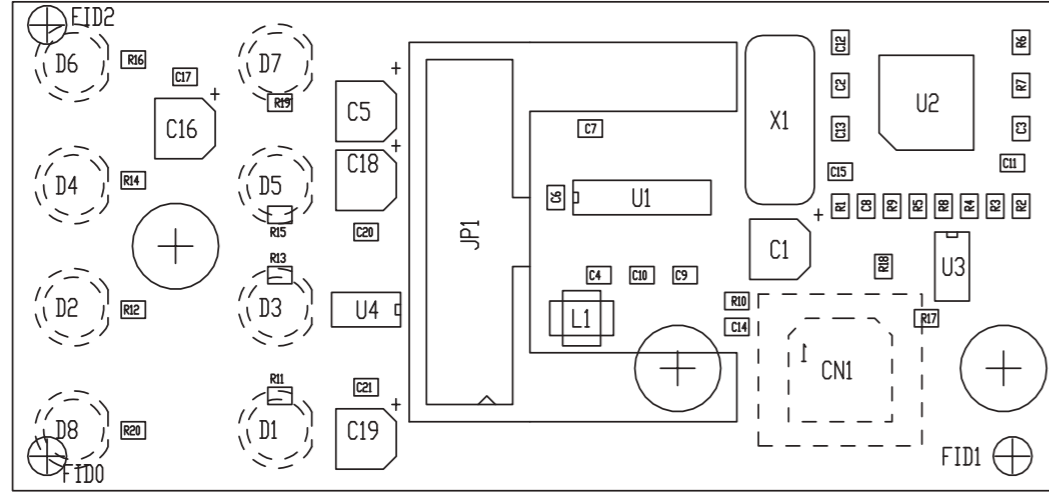

	NOME PROGETTO: EXCITER DTVPE	NOME PARTE: USB CONNECTOR CARD
	AUTORE: F. THEI	DATA: 18/04/05
ARCHIVIAZIONE ELETTRONICA: \RVRUT\	CODICE PROGETTO: 034	CODICE DISEGNO: SLIN0026R01V01
MATERIALE: <>	TRATTAMENTO: <>	PROFILO: <>
		STATO: ESECUTIVO

Nome Progetto: EXCITER DTVPE	Data: 13/07/2011	Pagina: 1 di 1	Size: A4
Autore: Tommasi A.	Revisione: 1.0	Codice Progetto: RVR147	
Nome PC in Rete: \RVRUT\	Autorizzazioni:	Nome Parte: USB Connector Card	
File/Cartella: /		Codice: SLIN0026R01V01	



SLIN0026R01V01

USB Connector Card Revised: Wednesday, July 13, 2011
 SLIN0026R01V01 Revision: 1.0
 A. Tommasi
 Exciter DTVPE
 RVR147

Item	Quantity	Reference	Part	Description
1	1	CN1	USB-B	Conn. Molex USB B 67265
2	1	CS1	CSIN0026R1	Circuito stampato
3	3	C1,C5,C16	10uF/16V	Cond. Elett. SMD d. 4mm
4	10	C2,C3,C4,C6,C7,C8,C9,C10, C15,C17	0.1uF	Cond. SMD 0805
5	1	C11	47nF	Cond. SMD 0805
6	2	C12,C13	27pF	Cond. SMD 0805
7	1	C14	10nF	Cond. SMD 0805
8	2	C18,C19	NC	Cond. Elett. SMD d. 4mm
9	2	C20,C21	NC	Cond. SMD 0805
10	3	D1,D4,D6	LED-Y5	LED dia. 5mm
11	2	D2,D8	LED-R5	LED dia. 5mm
12	3	D3,D5,D7	LED-G5	LED dia. 5mm
13	3	FIX1,FIX2,FIX3	FIX35	Foro fissaggio 3.5mm
14	1	JP1	CN16PD	Conn.M.C.S.Dritto 16P alette
15	1	L1	10uH	Ind. verticale SMD dia. 4 p 4.8
16	1	R1	470H0	Res. SMD 0805
17	2	R2,R3	27H0	Res. SMD 0805
18	1	R4	1K50	Res. SMD 0805
19	3	R5,R6,R10	0H0	Res. SMD 0805
20	5	R7,R8,R9,R17,R18	NC	Res. SMD 0805
21	8	R11,R12,R13,R14,R15,R16, R19,R20	390H0	Res. SMD 0805
22	1	U1	MAX202S	RS232 Driver SMD SO16
23	1	U2	FT232BM	SMD USB to RS232 interface
24	1	U3	NC	Serial EEPROM SMD
25	1	U4	NC	Stabilizzatroe SMD SO8
26	1	X1	6MHz	Quarzo SMD HC49SMD

SLPC0320R02V01

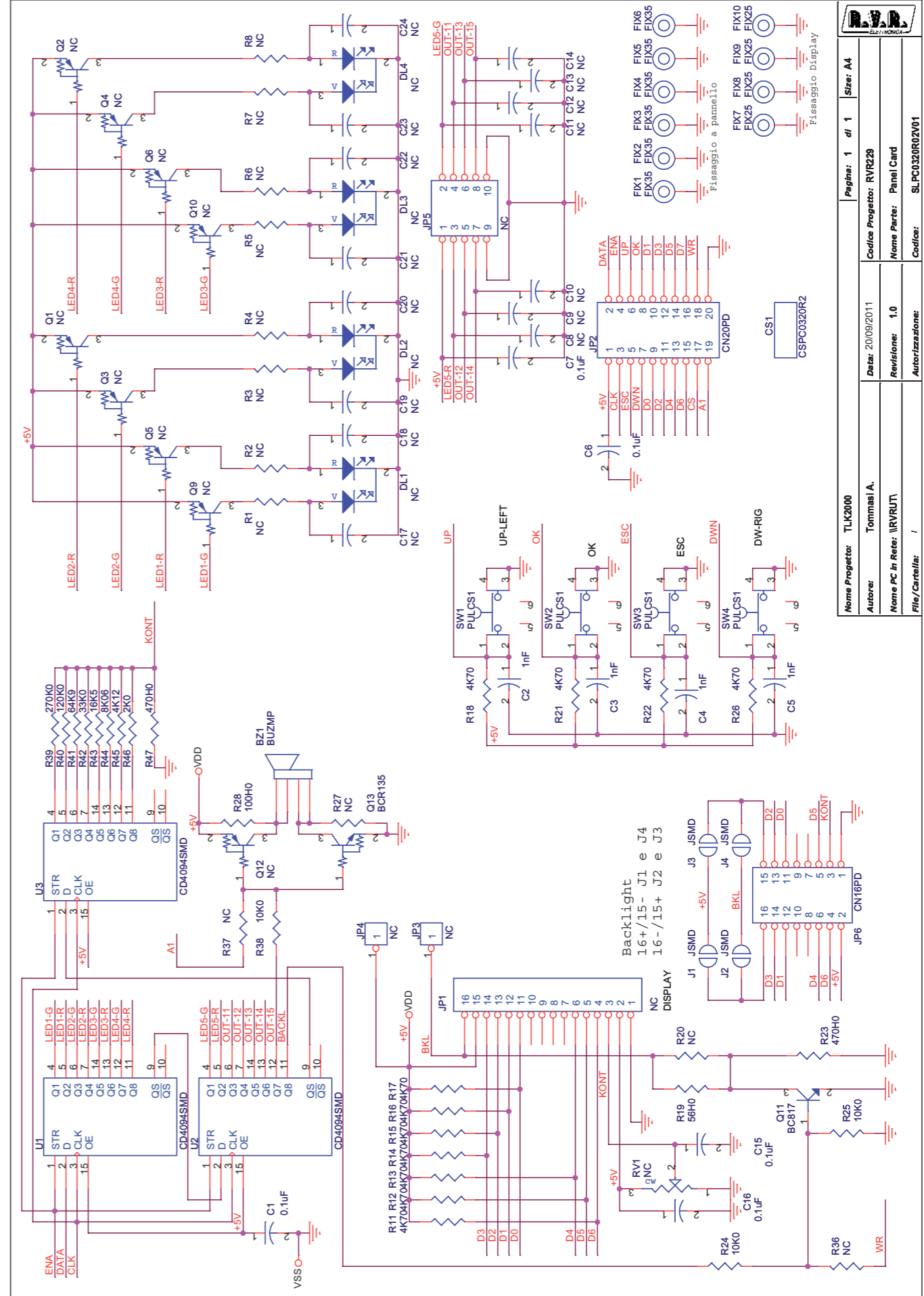
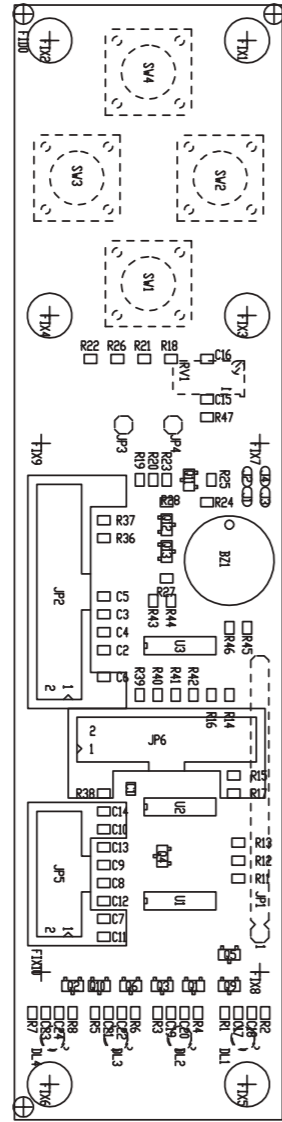

	NOME PROGETTO: TLK2000	NOME PARTE: PANEL CARD
	AUTORE: A. TOMMASI	DATA: 20/09/2011 REVISIONE: 1.0 SCALA: 1:1 SIZE: A4 PAGINA: 1 DI 1
ARCHIVIAZIONE ELETTRONICA: \\VRV\UT\	CODICE PROGETTO: 229	CODICE DISEGNO: SLPC0320R02V01
MATERIALE: <>	TRATTAMENTO: <>	PROFILO: <>
		STATO: ESECUTIVO

Nome Progettista: TLK2000	Autore: Tommasi A.	Data: 20/09/2011	Revisione: 1.0	Nome PC in Rete: \\VRV\UT\	File/Cartella: /
Codice Progettista: RV1229	Nome Partita: Panel Card	Autorizzazione:			
Pagina: 1 di 1	Size: A4	Codice: SLPC0320R02V01			

SLPC0320R02V01

Panel Card Revised: Tuesday, September 20, 2011
 SLPC0320R02V01 Revision: 1.0
 A. Tommasi
 TLK2000
 RVR229

Item	Quantity	Reference	Part	Description
1	1	BZ1	BUZMP	Buzzer TMB-05
2	1	CS1	CSPC0320R2	Circuito stampato
3	5	C1,C6,C7,C15,C16	0.1uF	Cond. SMD 0805
4	4	C2,C3,C4,C5	1nF	Cond. SMD 0805
5	15	C8,C9,C10,C11,C12,C13, C14,C17,C18,C19,C20,C21, C22,C23,C24	NC	Cond. SMD 0805
6	4	DL1,DL2,DL3,DL4	NC	Doppio led V-R 3mm Catodo com.
7	6	FIX1,FIX2,FIX3,FIX4,FIX5, FIX6	FIX35	Foro fissaggio 3.5mm
8	4	FIX7,FIX8,FIX9,FIX10	FIX25	Foro fissaggio 2.5mm
9	1	JP1	NC	Strip femmina 16 pin
10	1	JP2	CN20PD	Connettore 20 poli Flat cs
11	2	JP3,JP4	NC	Strip femmina 1 pin
12	1	JP5	NC	Connettore 10 poli Flat cs
13	1	JP6	CN16PD	Conn.M.C.S.Dritto 16P alette.
14	4	J1,J2,J3,J4	JSMD	Pad SMD a saldare
15	9	Q1,Q2,Q3,Q4,Q5,Q6,Q9,Q10, Q12	NC	Trans./Res. PNP SOT23
16	1	Q11	BC817	Trans. NPN SOT23
17	1	Q13	BCR135	Trans./Res. NPN SOT23
18	1	RV1	NC	Trimmer Rg V 3296W
19	12	R1,R2,R3,R4,R5,R6,R7,R8, R20,R27,R36,R37	NC	Res. SMD 0805 1%
20	11	R11,R12,R13,R14,R15,R16, R17,R18,R21,R22,R26	4K70	Res. SMD 0805 1%
21	1	R19	56H0	Res. SMD 0805 1%
22	2	R23,R47	470H0	Res. SMD 0805 1%
23	3	R24,R25,R38	10K0	Res. SMD 0805 1%
24	1	R28	100H0	Res. SMD 0805 1%
25	1	R39	270K0	Res. SMD 0805 1%
26	1	R40	120K0	Res. SMD 0805 1%
27	1	R41	64K9	Res. SMD 0805 1%
28	1	R42	33K0	Res. SMD 0805 1%
29	1	R43	16K5	Res. SMD 0805 1%
30	1	R44	8K06	Res. SMD 0805 1%
31	1	R45	4K12	Res. SMD 0805 1%
32	1	R46	2K0	Res. SMD 0805 1%
33	4	SW1,SW2,SW3,SW4	PULCS1	Pulsante cs
34	3	U1,U2,U3	CD4094SMD	Shift Reg. SMD SO16

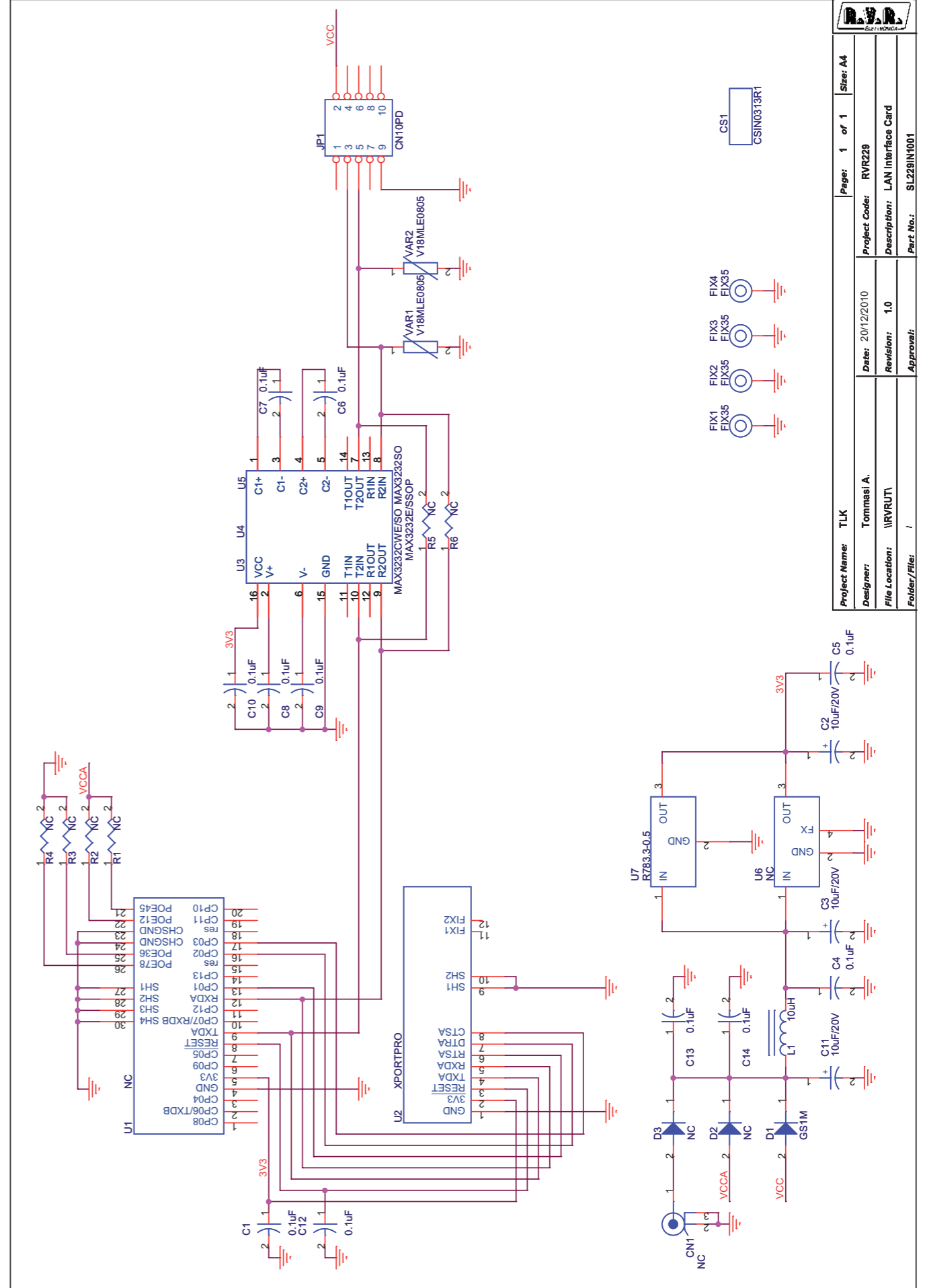
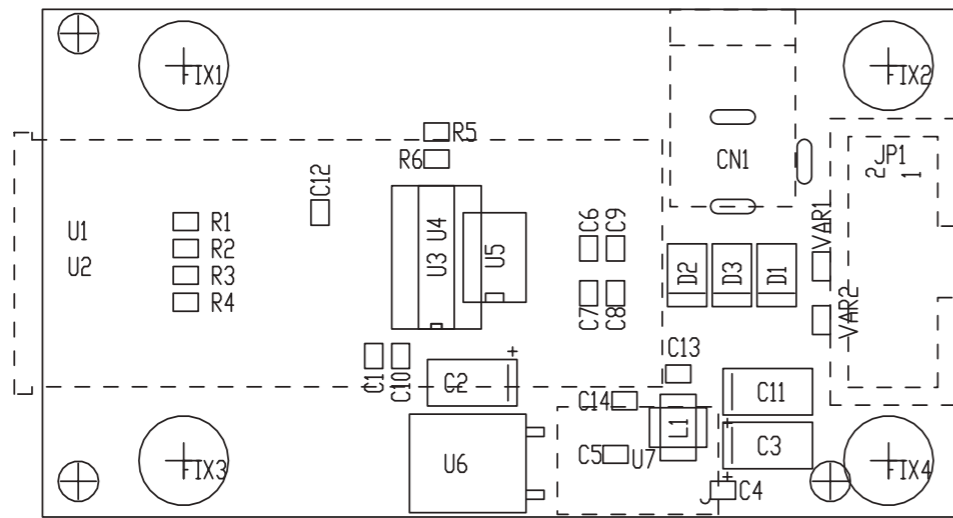

	NOME PROGETTO: TLK	NOME PARTE: LAN INTERFACE CARD
	AUTORE: A. TOMMASI	DATA: 20/12/2010
ARCHIVIAZIONE ELETTRONICA: \\RVR\UT\	CODICE PROGETTO: 229	CODICE DISEGNO: SL229IN1001
MATERIALE: <>	TRATTAMENTO: <>	PROFILO: <>
		STATO: ESECUTIVO

Project Name: TLK	Page: 1 of 1	Size: A4
Designer: Tommasi A.	Date: 20/12/2010	Project Code: RVR229
File Location: \\RVR\UT\	Revision: 1.0	Description: LAN Interface Card
Folder/File: /	Approval:	Part No.: SL229IN1001

SL229IN1001

LAN Interface Card Revised: Monday, December 20, 2010
 SL229IN1001 Revision: 1.0
 A. Tommasi
 TLK
 RVR229

Item	Quantity	Reference	Part	Description
1	1	CN1	NC	Connettore Alimentazione
2	1	CS1	CSIN0313R1	Circuito stampato
3	11	C1,C4,C5,C6,C7,C8,C9,C10,C12,C13,C14	0.1uF	Cond. SMD 0805
4	3	C2,C3,C11	10uF/20V	Cond. Elett. SMD tant. size C
5	1	D1	GS1M	Diodo SMD cont. SMA
6	2	D2,D3	NC	Diodo SMD cont. SMA
7	4	FIX1,FIX2,FIX3,FIX4	FIX35	Foro fissaggio 3.5mm
8	1	JP1	CN10PD	Connettore 10 poli Flat cs con alette
9	1	L1	10uH	Ind. verticale SMD dia. 4 p 4.8
10	6	R1,R2,R3,R4,R5,R6	NC	Res. SMD 0805
11	1	U1	NC	XPORT-AR Ethernet module
12	1	U2	XPORTPRO	XPORT-PRO Ethernet module
13	1	U3	NC	RS232 driver
14	1	U4	NC	RS232 Driver SMD SO16
15	1	U5	MAX3232E/SSOP	RS232 3V Driver SMD SSOP16
16	1	U6	NC	Stabilizzatore SMD DPAK
17	1	U7	R783.3-0.5	Switching SIP3 regulator
18	2	VAR1,VAR2	V18MLE0805	ESD SMD protector